

Radio-Electronics

FEBRUARY

TELEVISION • SERVICING • HIGH FIDELITY

HUGO GEFNSBACK, Editor-in-chief

ADD FM STEREO
WITH EASY-TO-BUILD
TRANSISTOR ADAPTER

CITIZENS BAND REPAIRS
YOU CAN MAKE
WITHOUT A LICENSE

BUILD THE TEMP-ALL
INSTANT ELECTRONIC
THERMOMETER

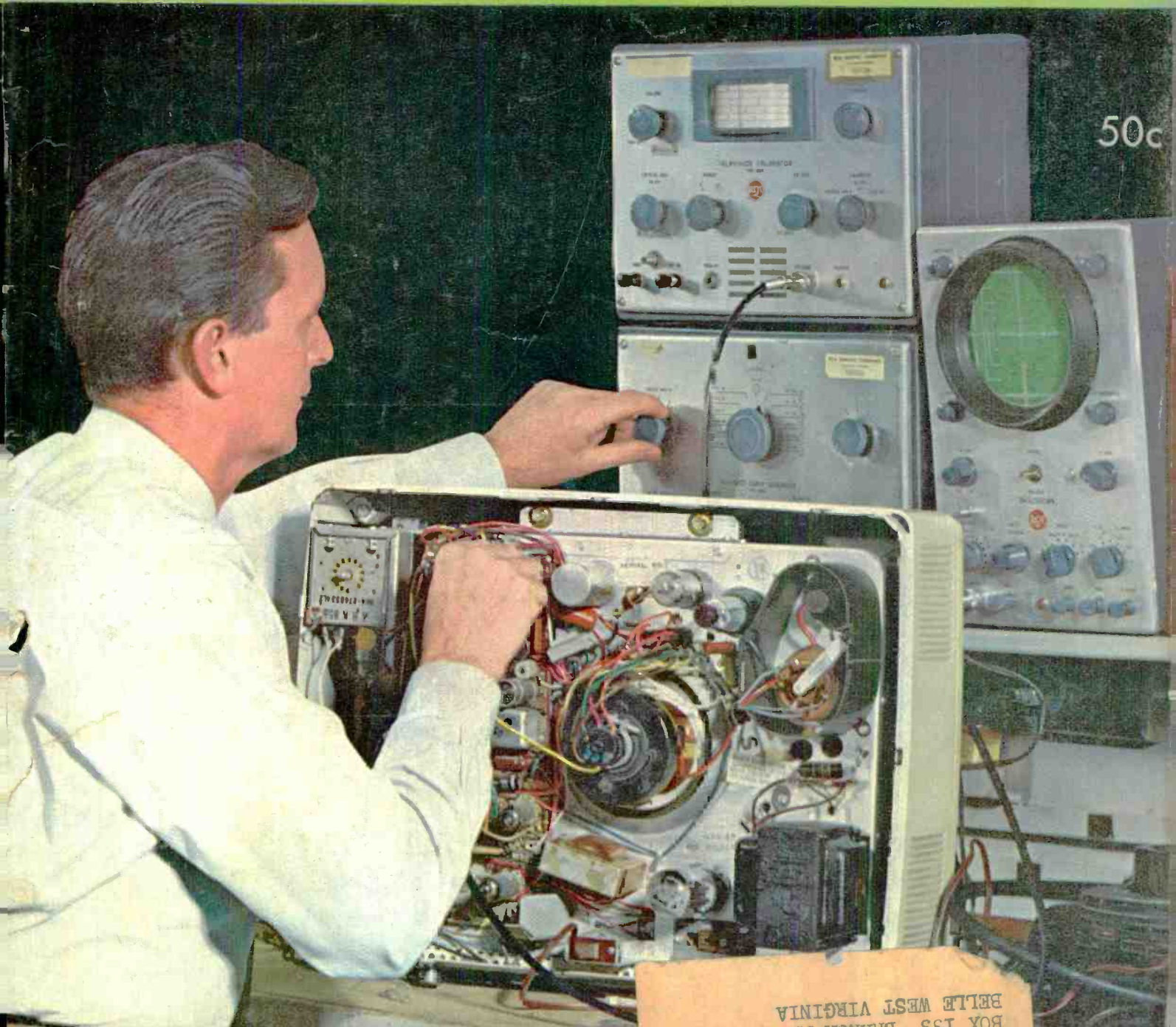

50c

WHAT DOES A SERVICE LAB DO? See page 4

A L FRIDY 9-63
BOX 133 BRANCH RD RT 1
BELLE WEST VIRGINIA

TRIPLET

EXTRA QUALITY IS HIDDEN*

MODEL 630 V-O-M PRICE† \$49.50

Standard Of The Industry



USES UNLIMITED:

- Field Engineers
- Application Engineers
- Electrical, Radio, TV, and Appliance Servicemen
- Electrical Contractors
- Factory Maintenance Men
- Industrial Electronic Maintenance Technicians
- Home Owners, Hobbyists

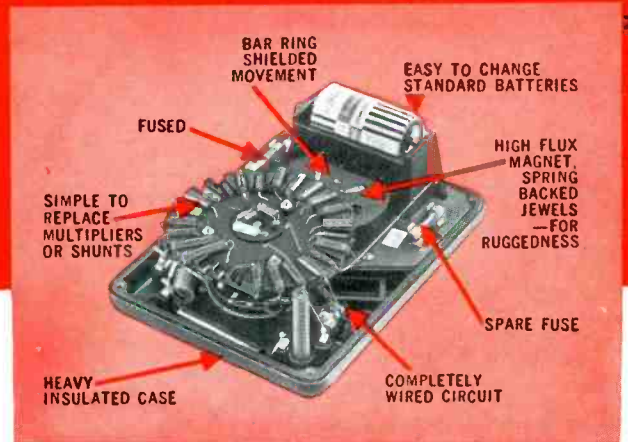

FACTS MAKE FEATURES:

- 1** Popular streamlined tester with long meter scales arranged for easy reading. Fuse protected.
- 2** Single control knob selects any of 32 ranges—less chance of incorrect settings and burnouts.
- 3** Four resistance ranges—from .1 ohm reads direct; 4½ ohm center scale; high 100 megohms.

Attention to detail makes the Triplet Model 630 V-O-M a lifetime investment. It has an outstanding ohm scale; four ranges—low readings .1 ohm, high 100 megs. Fuse affords extra protection to the resistors in the ohmmeter circuit, especially the X1 setting, should too high a voltage be applied. Accuracy 3% DC to 1200V. Heavy molded case for high impact, fully insulated.

†630A same as 630 plus 1½% accuracy and mirror scale only \$59.50

TRIPLET ELECTRICAL INSTRUMENT COMPANY, BLUFFTON, OHIO

RANGES

DC VOLTS	0-3-12-60-300-1,200-6,000 at 20,000 ohms per volt.
AC VOLTS	0-3-12-60-300-1,200-6,000 at 5,000 ohms per volt.
OHMS	0-1,000-10,000.
MEGOHMS	0-1-100.
DC MICRO-AMPERES	0-60 at 250 millivolts.
DC MILLI-AMPERES	0-1-2-12-120 at 250 millivolts.
DC AMPERES	0-12.

DB: -20 to +77 (600 ohm line at 1 MW).

OUTPUT VOLTS: 0-3-12-60-300-1,200; jack with condenser in series with AC ranges.

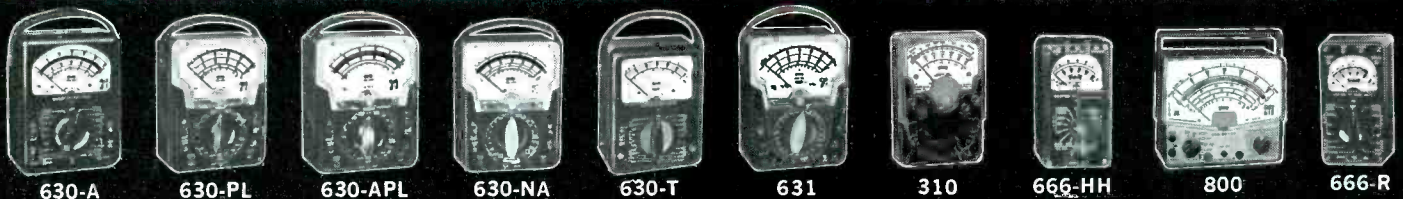

THE WORLD'S MOST COMPLETE LINE OF V-O-M'S. AVAILABLE FROM YOUR TRIPLET DISTRIBUTOR'S STOCK.

POWERMATE

—rated
No.
1

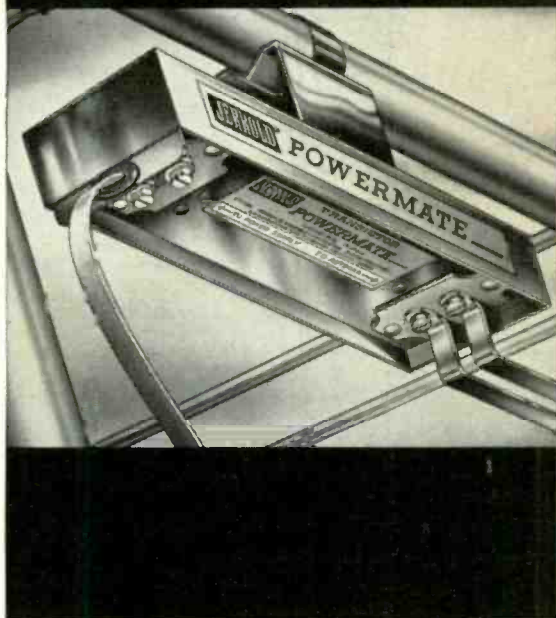

...the unquestioned leader in antenna-mounting preamplifiers

"Improved" models of other TV/FM antenna amplifiers may come and go, but Jerrold POWERMATE remains the one to beat.

Only POWERMATE delivers consistent high gain on both high and low bands—no "hills and valleys" to cause smearing and ghosting. And only POWERMATE offers the over-all reliability that cuts call-backs to the bone. Service-

men and viewers, even in deepest fringe areas, agree that POWERMATE outperforms them all . . . more customer satisfaction, more profit for you.

Are you getting your share of this POWERMATE-hungry market? See your Jerrold distributor today, or write Jerrold Electronics, Distributor Sales Division, Philadelphia 32, Pa.

JERROLD 

A subsidiary of THE JERROLD CORPORATION

Radio-Electronics

FEBRUARY 1963
VOL. XXXIV No. 2

Formerly RADIO CRAFT—Incorporating SHORT WAVE CRAFT—TELEVISION NEWS—RADIO & TELEVISION*

editorial

Hugo Gernsback 23 Human Electronic Transmitters

audio-high fidelity-stereo

27 New Automatic Tape Changer
Continuous 15 hours play with new system

David A. Williams 28 Add Stereo to Your FM With This Simple Adapter
Build this high-quality 8-transistor adapter

42 MULTIPATH DISTORTION—A THREAT TO FM STEREO?
A symposium of opinions by industry experts

James W. Essex 49 Electronic Music Is Here
Amateur or professional can find uses for it

electronics

Dick Barrett 31 What's Old

Dave Stone 45 Build the Temp-All
Electronic thermometer with 1,001 uses

47 What's Your EQ?

John A. Comstock 76 Unusual Bench Aids

industrial electronics

Ronald L. Ives 40 Contact Load Multipliers
Multiply current capacity of low-current contacts

66 Technician Shortage Worsens

Alex M. Schotz 74 Make Your Own Transformerless Intercom

radio

Jack L. Brayton 24 Imagination Plus
How one technician handles auto radio repairs

Jack Darr 34 CB Repairs You Can Make Without a License
You'll be surprised at what you can do

television

Larry Steckler 37 Tube Layouts in TV Sets
Airline 1961-1962

39 This Lab's Whole Job Is Service Research
(Cover Feature)

Robert G. Middleton 50 Unsuspected Cause of TV Color Failure
Let the scope find those defective capacitors

Jack Darr 56 Service Clinic
A diagnosis must be impartial

test instruments

Dave Stone 32 Audio Voltmeter Doubles as Preamp
All-transistor unit is completely portable

66 Equipment Report
Heath HO-10 monitor scope and Knight-Kit P-2 SWR power meter

I. Queen 70 Little Dipper
1-transistor dipmeter covers 3.8 to 100 mc

Ian N. McLeod 78 Solid Sync for Your Scope
Stop weak-signal bounce

the departments

21, 62 Corrections
21 Correspondence
117 New Books
86 New Literature

116 New Patents
105 New Products
88 New Semiconductors & Tubes

6 News Briefs
97 Noteworthy Circuits
79 Technicians' News

99 Technotes
94 Try This One
85 50 Years Ago

Over 50 Years
of Electronic Publishing

EDITOR-IN-CHIEF AND PUBLISHER

Hugo Gernsback

EDITOR

M. Harvey Gernsback

MANAGING EDITOR

Fred Shunaman

TECHNICAL EDITOR

Robert F. Scott, W2PWC

EDITORIAL ASSOCIATE

I. Queen

EDITORIAL ASSISTANT

Ramona Goldman

SERVICE EDITOR

Jack Darr

TECH. ILLUSTRATION DIRECTOR

Wm. Lyon McLaughlin

ART ASSOCIATE

Fred Neinast

DIRECTOR OF PRODUCTION

Elizabeth Stalcup

EASTERN SALES MANAGER

John J. Lamson

CIRCULATION MANAGER

G. Aliquo

DIRECTOR, NEWSSTAND SALES

Joseph L. Bund



Average Paid Circulation
Over 160,000

—on the cover—

(Story on page 39)

RCA Service Lab technician John J. Fisher, Jr. tracing down the cause of an obscure TV trouble at the Service Lab, Cherry Hill, N. J.

Color original by
Thomas Samicola

Gernsback Publications, Inc.

EXECUTIVE, EDITORIAL, ADVERTISING OFFICES

154 W. 14 St., New York 11, N.Y.
Telephone AL 5-7755

CHAIRMAN OF THE BOARD

Hugo Gernsback

PRESIDENT

M. Harvey Gernsback

SECRETARY

G. Aliquo



Radio-Electronics is indexed in
Applied Science & Technology Index
(Formerly Industrial Arts Index)

*Trademark registered U. S. Pat. Office

BREAK THROUGH TO HIGHER PAY

in **ELECTRONICS**

TV-RADIO

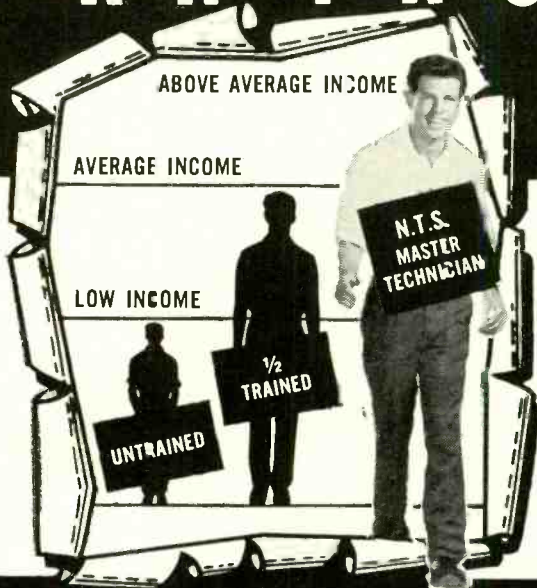

START NOW! Break through the Earning Barrier that steps half-trained men. N.T.S. "All-Phase" training prepares you — at home in spare time — for a high-paying CAREER in Electronics — TV — Radio as a MASTER TECHNICIAN. One Master Course at One Low Tuition trains you for unlimited opportunities in All Phases: Servicing, Communications, Preparation F.C.C. License, Broadcasting, Manufacturing, Automation, Radar and Micro-Waves, Missile and Rocket Projects.

A more rewarding job... a secure future... a richer, fuller life can be yours! As an **N.T.S. MASTER TECHNICIAN** you can go straight to the top in industry... or in your own profitable business.

You work on actual job projects

SUCCEED IN MANY HIGH-PAYING JOBS LIKE THESE...

- TV-Radio Sales, Service and Repair
- Profitable Business of Your Own
- Communications Technician — F.C.C. License
- Hi-Fi, Stereo & Sound Recording Specialist
- TV-Radio Broadcasting Operator
- Technician in Computers & Missiles
- Electronics Field Engineer
- Specialist in Microwaves & Servomechanisms
- Expert Trouble Shooter
- All-Phase Master Technician

19 BIG KITS YOURS TO KEEP

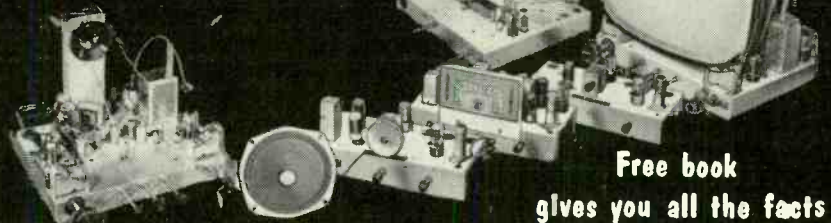

Free book gives you all the facts

NATIONAL TECHNICAL SCHOOLS

WORLD-WIDE TRAINING SINCE 1905
4000 SO. FIGUEROA ST., LOS ANGELES 37, CALIF., U. S. A.

Write Dept. RG-23



RESIDENT TRAINING AT LOS ANGELES

If you wish to take your training in our Resident School at Los Angeles, the world's TV capital, start NOW in our big, modern Shops, Labs, and Radio-TV Studios. Here you work with latest Electronic equipment — professionally installed — finest, most complete facilities offered by any school. Expert friendly instructors. Personal attention. Graduate Employment Service. Help in finding home near school — and part time job while you learn.

WRITE FOR SPECIAL RESIDENT SCHOOL CATALOG AND INFORMATION



ACCREDITED MEMBER

... the only nationally recognized accrediting agency for private home study schools.

N.T.S. Shop-Tested HOME TRAINING is **Better, More Complete, Lower Cost**... and it is your key to the most fascinating, opportunity-filled industry today!

YOU LEARN QUICKLY AND EASILY THE N.T.S. SHOP-TESTED WAY

You get lessons, manuals, job projects, unlimited consultation, graduate advisory service.

You build a Short Wave-Long Wave Superhet Receiver, plus a large-screen TV set from the ground up, with parts we send you at no addi-

tional cost. You also get a Professional Multitester for your practical job projects.

EARN AS YOU LEARN... WE SHOW YOU HOW!

Many students pay for entire tuition — and earn much more — with spare time work they perform while training. You can do the same... we show you how.

SEND FOR INFORMATION NOW... TODAY! IT COSTS YOU NOTHING TO INVESTIGATE.

N.T.S. HOME TRAINING is

- Classroom Developed
- Lab-Studio Planned
- Shop-Tested
- Industry-Approved
- Specifically Designed for Home Study

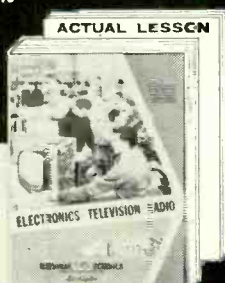

MAIL COUPON NOW for FREE BOOK and ACTUAL LESSON

NO OBLIGATION! NO SALESMAN WILL CALL

NATIONAL TECHNICAL SCHOOLS

WORLD-WIDE TRAINING SINCE 1905

Mail Now To
National Technical Schools, Dept. RG-23
4000 S. Figueroa St., Los Angeles 37, Calif.

Please rush FREE Electronics-TV-Radio "Opportunity" Book and Actual Lesson. No Salesman will call.

Name _____ Age _____
Address _____
City _____ Zone _____ State _____

Check here if interested ONLY in Resident Training at Los Angeles.
VETERANS: Give date of discharge _____

News Briefs

Low-Priced Video Recorder Announced by Ampex

A new television tape recorder, weighing less than 130 pounds and costing under \$12,000, was described by Ampex, who demonstrated a prototype at a special showing in New York City. The new recorder is one-twentieth the size and one-fourth the cost of the Ampex Videotape recorder, the first practical television recording device.

The new machine—the VR 1500—operates on the principle described in the article "New Video Tape Recorders," RADIO-ELECTRONICS, December 1962, page 64. The tape is scanned by heads rotating inside a drum around which the tape spirals. The result is a long, diagonal track on the tape. In the Ampex machine, instead of one head scanning 360°, two heads scan 180° each. The tape speed is 5 ips; the tape width 2 inches.

The new recorder is intended for such applications as educational television, where the need for a recorded video program is great, but where the cost of a broadcast type video tape recorder would put it beyond the means of the average institution. Military and industrial training, surgery and other applications were cited by Ampex spokesmen.

FCC Would Improve Citizens-Band Practices

The FCC has proposed rule changes for the Citizens band which, if adopted, may make the band less attractive to the hobbyist, but more useful to the serious operator. The proposed changes are applicable to the class-D category in the 26.96–27.23 band. Under the proposed new rule, only 5 channels of the present 23 would be available for communications between stations of different licensees. (Some legitimate business,

such as phoning ahead for reservations at a motel, requires intercommunication between stations of different licensees.)

Licensees on all other channels would be confined to their own units. Hobbyist types of chatter, such as communications to "any station that might be listening" or discussions as to types and excellence of equipment, antennas, etc., would also be illegal.

Bell Labs Announce Electret Microphone and Earphone

A quality condenser microphone and an earphone—also operating on the capacitor principle—that do not need high polarizing voltage, have been announced by Bell Telephone Labs. Instead, the new devices have a permanently polarized piece of dielectric material—an electret, the electrostatic equivalent of a permanent magnet.

Mylar film, coated with aluminum, was used for the dielectric. It was heated to 120°C in a 3,500-volt field and then gradually cooled in the field. The resulting polarization is about the same as would be produced by 200 volts external bias.

The construction of the earphone is somewhat like that of some modern electrostatic speakers, a push-pull principle being used. The earphone is flat within 3 db from 20 to 50,000 cycles, and the microphone from 50 to 15,000.

Are Lamps Devices For Making Light?

Though nearly 3,000,000,000 electric light bulbs are produced for illumination every year, several million lamps yearly are made for uses that have nothing to do with lighting, says Dr. Rolland Zabel, Westinghouse Lamp Div. engineering man-

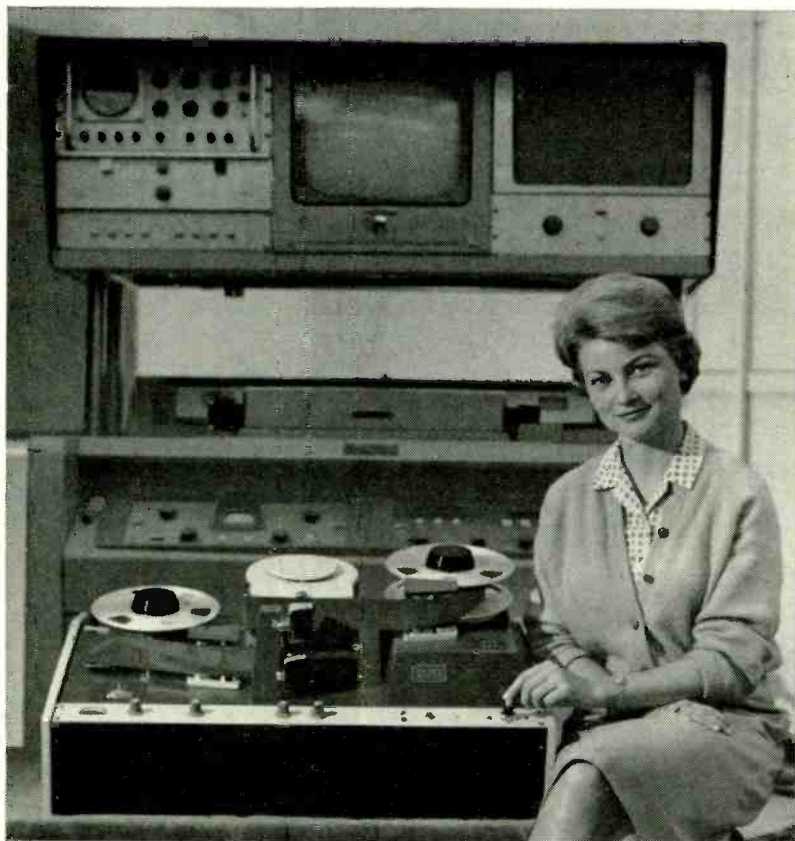

New Ampex VR-1500, photographed in front of the standard Ampex VR-1000C recorder used in broadcasting. Model Phyllis Maness demonstrates simplicity of new recorder—one push and it's on, another and it's off.

Advertising Representatives: South—J. Sidney Crane & Associates, 22 8th St. N.E., Atlanta, Ga., Tel. TRinty 2-6720. Florida: Neff Associates, 15 Castle Harbor Isle, Fort Lauderdale, Fla., Tel. LOgan 6-5656. West—Husted-Coughlin, Inc., 1830 W. 8th St., Los Angeles, Calif., Tel. 389-3132. 444 Market St., San Francisco, Calif., Tel. GARfield 1-0151. United Kingdom—Publishing & Distributing Co., Ltd., Mitre House, 177 Regent St., London, W.1, England. Subscription Service: Address form 3579 and correspondence to Radio-Electronics, Subscriber Service, 154 West 14th St., New York 11, N. Y. When requesting a change of address please furnish an address label from a recent issue. Allow one month for change of address.

3 More Big Training Advantages



DeVRY Tech Exclusive!

WITH TRANSISTORIZED METER . . . PLUS NEW "MODULAR CIRCUITS" TO BUILD AT HOME!

Now Prepare for GOOD JOB OPPORTUNITIES IN ELECTRONICS Faster—with

1. **METER** — Transistorized, Portable, AC-DC Multimeter
2. **SCOPE** — 5-inch New Streamlined Commercial-Type Oscilloscope
3. **ELECTRO-LAB*** — For 3-Dimension Circuit Building

To help you get ready F-A-S-T-E-R . . . and THOROUGHLY . . . for good-paying job opportunities in the fast growing Electronics field, DeVry Technical Institute now presents the newest and finest training advantages in its over 30 years of experience. Now . . . AT HOME . . . in your spare time, you prepare with "industry-type" home laboratory equipment. To provide real PRACTICAL EXPERIENCE, you build a quality Transistorized Meter and a 5-inch industrial-type Oscilloscope . . . work with small, 3-dimensional circuits on DeVry's new Design Console . . . use highly instructive home training movies . . . and follow up-to-date lessons with many time-saving fold-out diagram sheets.

Little wonder DeVry men qualify for such fine opportunities in Space-Missile Electronics, Automation, Computer Work, Radio-TV, Industrial Controls, and other fields.

You learn PRACTICAL techniques important in today's Space Age industry, because you build many compact circuits with the streamlined Electro-Lab, using exclusive solderless "modular connectors." You perform over 300 construction and test procedures in all! Your self-built test equipment has function-grouped controls, meter scales color-keyed to the panel markings—much like instruments used on today's jobs. What's so important, the home laboratory and the test equipment are YOURS TO KEEP!

INDUSTRY NEEDS TRAINED MEN

Through this remarkable 3-way method, DeVry Tech has helped thousands of ambitious men prepare for good jobs or their own profitable full-time or part-time service shops. It is the newest in a long series of PRACTICAL training aids that we have pioneered and developed in more than three decades of experience. Sound interesting? Then see how DeVry Tech may help YOU. Mail the coupon today.

From RADIO to SPACE-MISSILE ELECTRONICS

DeVry's training goes all the way from radio repair . . . to space-missile electronics. That's the range of subjects covered in its programs AT HOME or in its well-equipped training centers in Chicago and Toronto. You learn up-to-date techniques, working with new equipment, modern texts, movies—one of today's finest combinations of training equipment . . . geared for RESULTS!

EMPLOYMENT SERVICE

When you complete the program, DeVry's efficient Employment Service is ready to help you get started. There is no extra charge—ever—for this aid. ACCREDITED MEMBER, NATIONAL HOME STUDY COUNCIL

DeVRY TECHNICAL INSTITUTE
CHICAGO • TORONTO

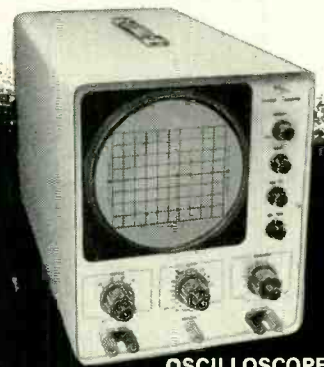

OSCILLOSCOPE

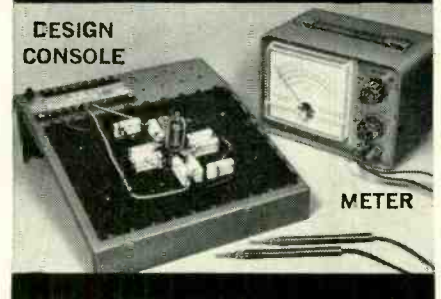

DESIGN CONSOLE

METER

*Trademark ©

MAIL COUPON FOR FREE FACTS

DEVRY TECHNICAL INSTITUTE
4141 Belmont Ave., Chicago 41, Ill., Dept. RE-2-T 2082

Please give me your two free booklets, "Pocket Guide to Real Earnings" and "Electronics in Space Travel"; also include details on how to prepare for a career in Electronics. I am interested in the following opportunity fields (check one or more):

- | | |
|------------------------------------------------------|-------------------------------------------------|
| <input type="checkbox"/> Space & Missile Electronics | <input type="checkbox"/> Communications |
| <input type="checkbox"/> Television and Radio | <input type="checkbox"/> Computers |
| <input type="checkbox"/> Microwaves | <input type="checkbox"/> Broadcasting |
| <input type="checkbox"/> Radar | <input type="checkbox"/> Industrial Electronics |
| <input type="checkbox"/> Automation Electronics | |

Name _____ Age _____

Address _____ PLEASE PRINT _____ Apt. _____

City _____ Zone _____ State _____

Check here if you face military service.

Canadian residents: Write DeVry Tech of Canada, Ltd.
970 Lawrence Avenue West, Toronto 19, Ontario

Pack up your troubles

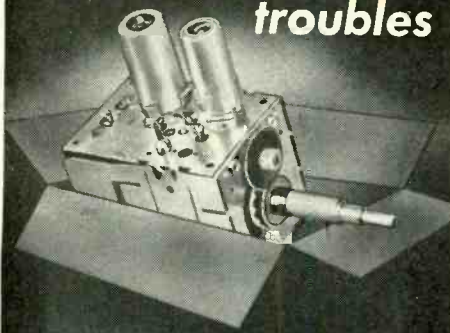

and send them to
CASTLE

Ask yourself

... do you have the time to fool around drilling, sawing, filing ... trying to make a "Universal" replacement tuner fit in place of the original? Do you have all the expensive instruments and equipment to complete the alignment so essential after each tuner repair or replacement? Can you spare the time repairing and adjusting your own TV tuners and can you charge enough to justify the time spent?

A Castle Overhaul eliminates every one of these problems.

Castle replaces all defective parts (tubes and major parts are extra at net prices) and then aligns your tuner to the exact, original specifications. Simply send us your defective tuner complete; include tubes, shield cover and any damaged parts with model number and complaint.

ALL MAKES ONE PRICE

VHF TUNERS
UHF TUNERS
UV COMBINATIONS*

9⁹⁵

*UV combination tuner must be of one piece construction. Separate UHF and VHF tuner with cord or gear drives must be dismantled and the defective unit sent in. 90 Day Warranty.

Send for FREE Mailing Kit and complete details

CASTLE
TV TUNER SERVICE, INC.

Check Map for the
Castle Center Serving You.

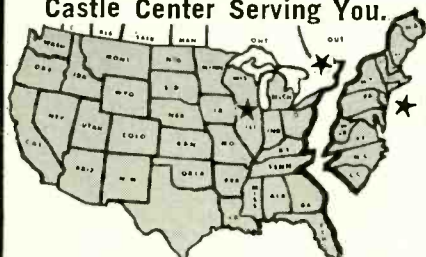

5715 N. WESTERN AVE. CHICAGO 45, ILLINOIS
653 PALISADE BLVD., CLIFFSIDE PARK, N. J.
CANADA: 136 MAIN ST., TORONTO 13, ONTARIO

Pioneers in



TV Tuner Overhauling



These trays of meat balls were cooked by quartz infrared heat lamps.

ager. These lamps do such jobs as taking toughness out of steak, keeping food fresh, helping capture criminals, and making motion pictures talk.

One common nonilluminating lamp is the ultraviolet radiator, used in crime detection, in prospecting to detect fluorescent minerals, and to destroy germs. Industrial ultraviolet tubes are used in photochemical processes such as the production of fertilizer, the development of colors and dyes, bleaching fabrics and even tenderizing meat.

At the other end of the scale is the infrared, or heat lamp, used for drying, baking paint on automobiles, gluing and even cooking. The cesium lamp is used for invisible signaling by the military, and for developing the sound on motion picture film.

While a third type of lamp produces visible light, it may have special uses, such as a group of fluorescent lamps designed especially to stimulate plant growth, or an artificial sunlight lamp used to produce sultan.

Citizens Band Has Own Show

Citizens-band equipment stole the show at the first International Communications Fair held late in November at the New York Coliseum. The great majority of the more than 75 commercial exhibitors were demonstrating Citizens-band equipment. Other types of communications were in evidence, including a number of ham radio booths and an amateur radio demonstration setup, as well as 25 educational exhibits. Marine communications manufacturers were also present, and one booth—Craftsman Instrument Laboratory—was operated by a manufacturer of a television camera kit.

Telstar Refuses To Take Orders

The Bell Telstar satellite, after four months of successful operation, developed trouble in the system which turns its communications re-

ceiver and transmitter on and off, making it impossible to use it as a radio and television relay. The telemetry circuits were at last reports still working perfectly, sending back reports on the amount of radiation in space, the condition of the satellite and its components, temperature readings, effects of radiation on the solar cells and transistors—in fact, almost everything except why the command circuit won't work.

Double Medal of Honor Given by IRE

The IRE (now IEEE) has chosen two recipients for the Medal of Honor, its highest annual technical electronics award. John Hayes Hammond, Jr., president of Hammond Research Corp., Gloucester, Mass., will receive the award for theoretical work in radio control of missiles, and George Clark Southworth, consultant of Chatham, N. J., for achievement in the fields of radio physics, radio astronomy and waveguide transmission. For leadership in scientific research and education, Frederick Emmons Terman, vice president and provost of Stanford University, will receive the Founders Award, a special-occasion honor for outstanding service to the profession. Contributors to the fields of radio art, technical authorship and electronic television are honored by five remaining awards.

Presentations will take place on March 27 at the Waldorf-Astoria Hotel in New York City.

100 Conversations Carried On Single Telephone Path

A new British electronic telephone exchange permits subscribers to carry on perfect telephone conversations, though they are connected to the line only 1% of the time.

The principle is called "time division multiplex," and consists of a crystal-controlled switching system operating at 1 mc. Each of 100 telephone lines is gated "on" with a semiconductor diode 10,000 times

In COMPONENTS if it's news, expect it first from IRC



NEW... IRC Vinyl Electrical Tape Fast, safe one-hand insulating

New IRC Type 103 Vinyl Electrical Tape has everything a good tape should have . . . and then some.

- 2 to 18 times better dielectric strength than other tapes.
- Seals and insulates in one fast tape-and-tear operation . . . saves tape and time. UL approved as a single insulation for wire splices.
- Saves space in confined areas . . . ends "twice-around" wraps with bulky tapes.
- Provides a tight insulated plastic seal . . . resistant to abrasion, water, acids, alkalies, corrosion and aging.
- Gives a neater wrap . . . adheres readily to irregular surfaces and contours.
- Makes an excellent wrap for insulating tools.

TAPE-AND-TEAR DISPENSER

For fast, one-hand taping IRC Vinyl Electrical Tape comes to you in a sturdy tape-and-tear dispenser. It keeps tape clean and prevents stretching. Cutting blade is shielded for your protection. Dispenser is loaded with 66 feet of $\frac{3}{4}$ " tape . . . ready for instant use.

Also available in cellophane wrapped rolls:

- $\frac{3}{4}$ " wide by 20 feet long
- $\frac{3}{8}$ " wide by 20 feet long
- $\frac{3}{8}$ " wide by 36 yards long

Ask for IRC Vinyl Electrical Tape at your Electronic Parts Distributor.

International Resistance Co., Philadelphia 8, Pa.



VERY BIG ON RESPONSE

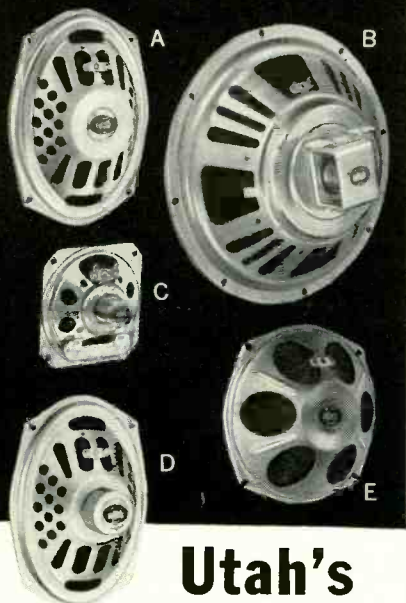

Utah's famous micro-gap replacement SPEAKERS

Better response — better sound reproduction than original equipment! Better customer response, too, when you install Utah Micro-Gap replacement speakers. Single-packed in custom-fitted cartons. Illustrated above:

A SP69NF 6x9" Oval Inverted Auto Speaker **B** SP12J 12" Round Speaker **C** SP4A 4" Square Outdoor Speaker **D** SP69G 6x9" Oval Auto Speaker **E** SP8NF 7½" Inverted Pin Cushion Speaker.

Write for illustrated literature



HUNTINGTON, INDIANA

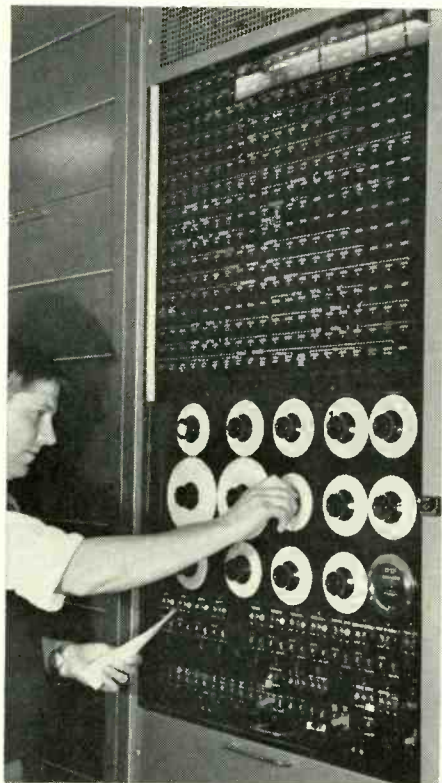

Engineer inserting information into the magnetic memory of the exchange.

per second, and a 1-microsecond sample of each caller's voice is taken and transmitted down the line. A similar switching device at the other end picks up the 1- μ sec sample and routes each to its proper circuit.

Since 10,000 samples are taken per second, the listener at the other end of the line cannot hear any noticeable difference from "solid" conversation, even though a single syllable may have been broken into hundreds of pulses. Speech quality, in fact, is stated to be considerably higher than required for ordinary telephone work, with a flat response from 300 to 4,200 cycles per second.

The new exchange is also completely automatic, with a magnetic memory storing all the information relating to each line and recording the number and duration of each call. It accepts calls from one subscriber and routes them through, calling on other sections of the memory for the correct instructions to make the connection. The 800-phone exchange acts as if it had only one operator handling *all* the calls one at a time, but an operator working so rapidly that the subscriber can detect no delay in the completion of his call.

Ricardo Muniz Passes

Pioneer author, engineer and manager in the radio and TV fields, Ricardo Muniz died Nov. 17 at the age of 52. He had just retired as director of engineering and coordinator of manufacturing of Magnavox.

Mr. Muniz will be remembered by older readers of Gernsback's magazines as author, co-author and inspirer of a number of projects at the Brooklyn Technical High School. At the time of his death, he was collaborating on a text "Electronic Instrumentation," to be published this spring.

After the war, he pioneered in TV production as general manager at the A. B. Du Mont Laboratories, and later held executive positions in a number of the larger radio and TV companies.

FCC Adopts Uhf Rules

The technical standards for uhf TV receivers recommended by the manufacturers last summer (RADIO-ELECTRONICS, September, 1962, page 6) have been adopted by the FCC without notable changes. All sets shipped in interstate commerce after April 30, 1964, must be equipped to receive all channels. Sensitivity of the uhf channels is to be not more than 8 db below the average of the sensitivity of the vhf channels.

A request has been made to the FCC for a special ruling to cover equipment used in schools, hospitals, hotels, and similar community antenna type systems, where the signal is received on uhf but converted to vhf for cable distribution to the receivers. In such cases there would be no point in having uhf channels.

TV Replacements Increase

Two-thirds of the TV sets sold in 1962 were replacements for sets that were junked, according to Frank W. Mansfield, Sylvania marketing research director. About 4,300,000 TV sets were scrapped in 1962, he believes. This compares with 3,700,000 in 1961. Total TV sets discarded to date number about 26,000,000, out of the roughly 86,000,000 sold in the United States. About 60,200,000 TV sets were in use at the end of 1962, estimates Mr. Mansfield.

"High Fidelity" Defined?

The Electronic Industries Association, the audio portion of whose membership generally represents the larger packaged hi-fi manufacturers, has proposed a definition of high fidelity, which has been turned over to the FTC for consideration. The definition classifies any instrument with relatively constant response of 100 to 8,000 cycles and power output of at least 5 watts as high fidelity. [This definition sounds more like *infidelity!* —Editor] According to EIA's consumer products staff director, L. M. Sandwick, this is to be a "minimum definition," which "may well change as the art improves."

RADIO-ELECTRONICS

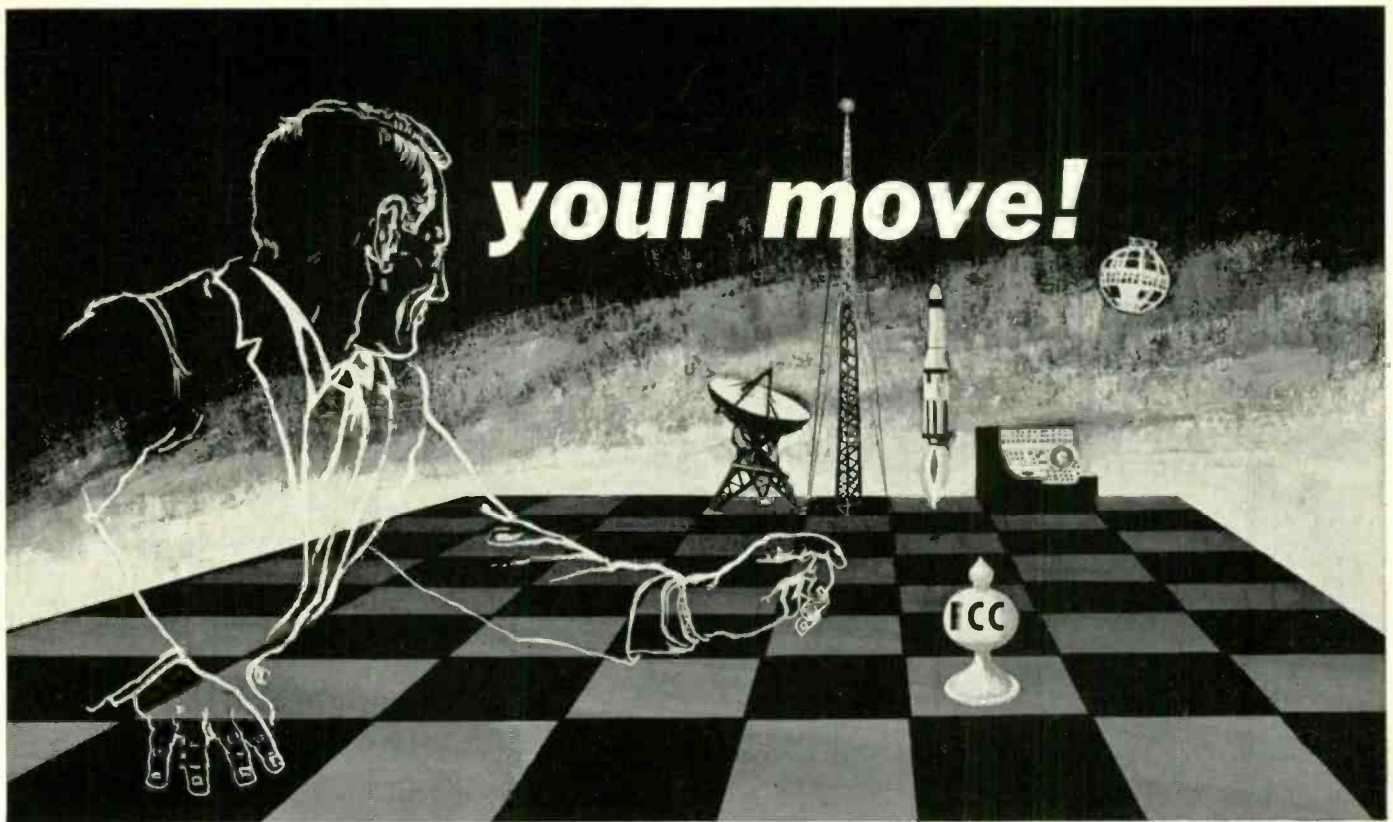

The move into electronics is your decision. GRANTHAM SCHOOL OF ELECTRONICS makes your move easier...

...easier by teaching you electronics in a logical, step-by-step manner, while preparing you to qualify for your **First Class Commercial FCC License**. This license is a "diploma" issued by the U. S. Government to certify qualified electronics technicians, and is awarded only to those who pass certain technical FCC examinations. We teach you electronics and prepare you to pass these FCC examinations.

Grantham training is **Specialized Training**, endorsed and recommended by many electronics firms throughout the nation, and accredited by the National Home Study Council. We teach you the **how** and **why** of basic electronics, with the necessary math taught as an integral part of the lessons. The

course is thorough, easy to understand, and lays a solid foundation for all types of electronics work—communications electronics, military electronics, computer electronics, automation electronics, broadcasting electronics, and many more.

The time required to prepare for your first class FCC license, an important step toward your goal, is cut to a minimum through quality instruction—**either by home study or in resident classes**. You learn more electronics in less time because the Grantham Method is engineered with the student in mind. Complete details concerning Grantham training are available free for the asking. Now, it's up to you—it's your move!



GRANTHAM

SCHOOL OF ELECTRONICS

Accredited Member of the National Home Study Council

1505 N. Western Ave.
Los Angeles 27, Calif.
(Phone: HO 7-7727)

408 Marion Street
Seattle 4, Wash.
(Phone: MA 2-7227)

3123 Gillham Road
Kansas City 9, Mo.
(Phone: JE 1-6320)

821 - 19th Street, N.W.
Washington 6, D. C.
(Phone: ST 3-3614)

(Mail in envelope or paste on postal card)

34-B

To: GRANTHAM SCHOOL OF ELECTRONICS
NATIONAL HEADQUARTERS OFFICE
1505 N. Western Ave., Hollywood 27, Calif.

Gentlemen:

Please send me your free booklet telling how I can get my commercial F.C.C. license quickly. I understand there is no obligation and no salesman will call.

Name _____ Age _____

Address _____

City _____ State _____

I am interested in: Home Study, Resident Classes

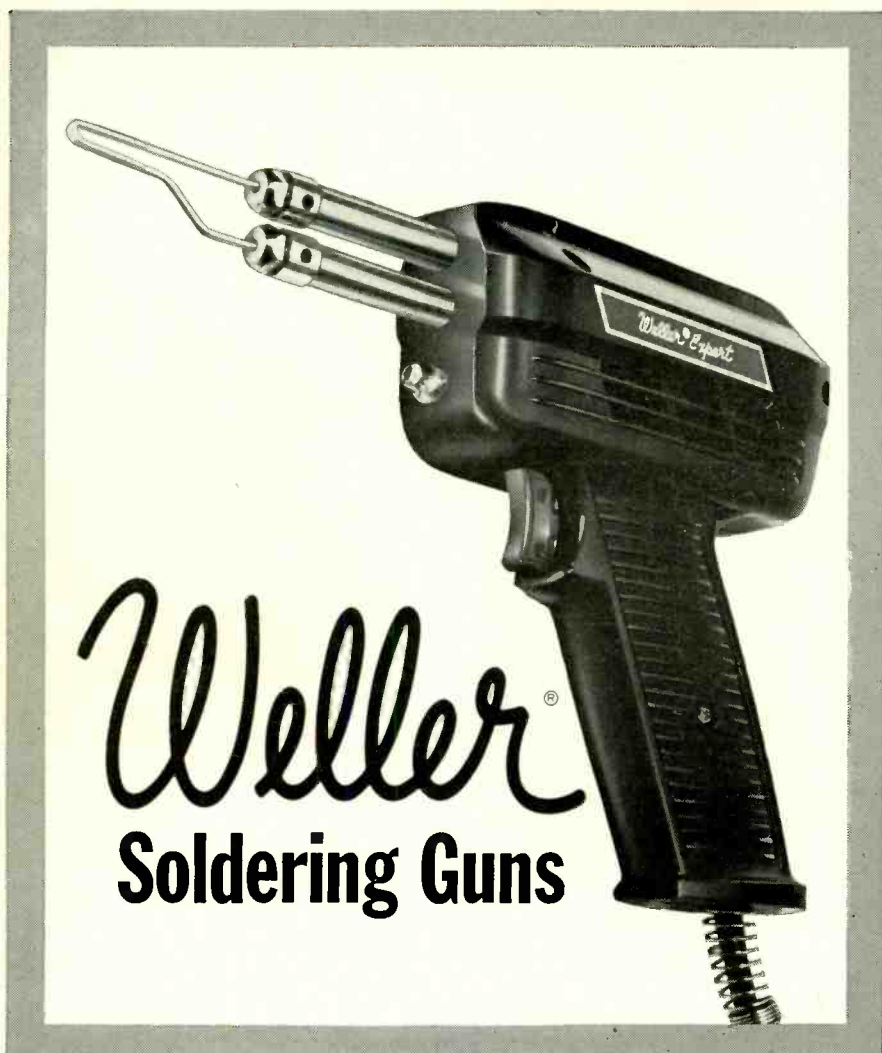

OVER
5 MILLION
SOLD

ALL MODELS
DUAL HEAT

YOUR
BEST BUY

2 soldering temperatures. An original Weller feature that provides 2 trigger positions, lets you switch instantly to high or low heat to suit the job.

Prevents damage to critical components. You use low heat when working with heat-sensitive components.

Tip lasts longer. Dual Heat enables you to prolong tip life by using high heat only when necessary.

Weller Dual Heat Soldering Guns are available in many models with ratings from 100/140 to 240/325 watts. Also supplied in plastic-case kits with accessories. All Weller Guns are guaranteed 1 year.

At your Electronic Parts Distributor

WELLER ELECTRIC CORP., 601 STONE'S CROSSING RD., EASTON, PA.

Gives full, constant heat. Wiping action of tip nuts eliminates contact resistance, oxidation.

Solders in seconds. No waiting. Saves time and current.

No danger from an idling hot tool. Heat is instantly "on" or instantly "off".

Spotlight illuminates work. Eliminates shadows.

Comfortable in use. Pistol grip fits hand naturally, remains cool.

To judge from the record, the art of commercial definitions for high fidelity is improving rather slowly. In 1934, the Engineering Div. of RMA (predecessor of EIA) interpreted, tentatively, high fidelity as applying only to a receiver having an af range of at least 50 to 7,500 cycles, with variations not to exceed 10 db, and with a total output of at least 10 watts, total distortion not exceeding 5% (*Radio-Craft*, Sept. 1934, page 151).

Skip-puter?

With a computer for a skipper and a crew consisting of automatic machines, Soviet diesel ship Laboratoria has completed an experimental voyage on the Dnieper River. Depth finders registered soundings and the electronically controlled ship's log kept dutiful records. A cable on the river bottom sets up a magnetic field that the shipboard instruments use to set the course. The ship, a floating laboratory, collects data for Kiev scientists who are studying ship automation—and does it all, say the Soviets, without human personnel.

TV Campus Grows

Florida's ETV network is showing the nation that TV can cope with teacher shortages. In 1961, TV was a part of the curriculum for more than a third of the state's pupils—and the system is still growing. Within the next 12 years, the 6-station network should expand to 12 stations. The system, a low-budget operation, is run and programmed by the state Educational TV commission. Stations are owned by local school boards, state universities and nonprofit community groups. Each station has its own video-tape recorder to help distribute lessons throughout the state. Next on the list for an ETV installation is Orlando, channel 24.

R-E Author Passes

Ralph W. Hallows, who between the years 1946 and 1950 wrote the column "European Report" in this magazine, has died in England at the age of 77. Major Hallows also, under the penname "Diallist," conducted the feature "Random Radiations" in the British magazine *Wireless World* for over 25 years. He was the author of articles in this magazine and other magazines, and author or co-author of several books on radio and radar.

Too Much Soap in Your Ears?

It's not just your imagination—TV commercials often are louder than the programs. H. H. Scott, Inc., after electronically testing three Boston TV stations, stated these findings: On 65% of the monitored programs, commercials were louder—
(Continued on page 16)

PRETTY
as a picture



...TOUGH
as nails!

Model 641



SETTING NEW STANDARDS IN SOUND

**THE NEW ELECTRO-VOICE
MODEL 641 AND 634
UTILITY MICROPHONES**

Now! An exciting new answer to your most demanding microphone needs! The Electro-Voice Model 641 and 634 utility microphones. Handsome new style wedded to rugged, dependable performance. Looks good anywhere... sounds great everywhere!

Specify the Model 641 for floor or desk stand use in school sound systems, tape recorders or industrial applications. Choose the Model 634 for custom mounting on boom or gooseneck in language laboratories, paging systems or wherever semi-permanent mounting is required.

Identical except for mounting, the 641 and 634 both feature a precision dynamic element with remarkable E-V Acoustalloy® diaphragm for smooth, peak-free response and unparalleled reliability despite high shock, moisture or heat. The generous diameter plus a high-energy magnetic structure offers excellent sensitivity for every application.

The precision dynamic element is carefully "packaged" in modern, unbreakable Cyclo-lac* plastic combined with a satin-chromium finished, high-density die casting that soaks up abuse yet stays attractive for years. Handy on-off switch is included. Choice of high- or balanced low-impedance models.

In every way these fresh new dynamics set new standards of appearance and performance... yet the price is surprisingly low! The result of advanced engineering plus the most modern and efficient production facilities in the industry! Make the Electro-Voice Models 641 and 634 your new standards of utility microphone excellence, today!

* T. M. Borg-Warner



Model 634

SPECIFICATIONS: Response 70-10,000 cps. Omni-directional. Sensitivity -57 db (Hi-Z, ref. 0 db = 1 volt/dyne/cm²). Available Hi-Z or balanced 150 ohms. 641: 5/8"-27 mounting, 6-foot cable with connector at microphone. \$35.00 List. 634: 5/8"-27 thread at back. 6-foot cable coaxial with mounting thread. \$31.50 List. (Normal trade discounts apply).



ELECTRO-VOICE, INC.
Dept. 232E, Buchanan, Michigan

Two outstanding products by the HIDDEN

600*

who plan for your future:



DIFILM® BLACK BEAUTY® CAPACITORS
molded tubular



DIFILM® ORANGE DROP® CAPACITORS
dipped tubular

TWO GREAT TUBULARS . . . TAKE YOUR CHOICE!

(± 10% Capacitance Tolerance is standard at no extra cost)

- Sprague Difilm Capacitors can't be beat! Dual-dielectric construction combines the best features of both Mylar® polyester film and special capacitor tissue. And for additional reliability, Difilm capacitors are impregnated with Sprague's HXC®, a solid impregnant which produces a rock-hard capacitor section—there's no wax to drip, no oil to leak!
- **BLACK BEAUTY Molded Tubulars** are actually low-cost versions of the famous Sprague high-reliability capacitors used in modern military missiles. They're engineered to withstand 105°C (221°F) temperatures . . . even in the most humid climates! And their tough, molded phenolic cases can't be damaged in handling or soldering.
- **ORANGE DROP Dipped Tubulars** are the perfect replacement for radial-lead capacitors now used by leading manufacturers of TV sets. Leads are crimped for neat mounting on printed wiring boards. Extremely small in size, they'll fit anywhere, work anywhere. And they're double-dipped in epoxy resin for extra protection against moisture.

*The "Hidden 600" are Sprague's 600 experienced researchers who staff the **largest research organization in the electronic component industry** and who back up the efforts of some 8,500 Sprague employees.

Get your copy of Catalog C-614 from any Sprague distributor, or write Sprague Products Co., 81 Marshall Street, North Adams, Massachusetts.



looks innocent...but this chassis has a "tough dog"* repair problem

*no picture—raster okay—sound distorted

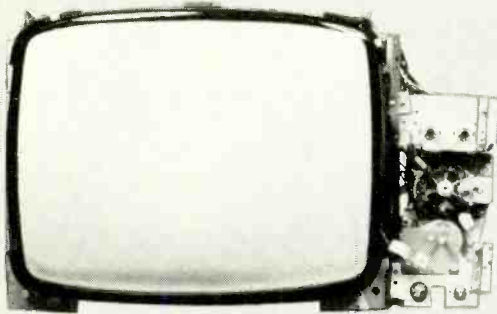

you may be able to solve the trouble in an hour or more or you can do it in minutes



With a PHOTOFACT® Folder by your side, the job takes just minutes. You use the Tube Placement and Tube Failure Check Charts (found in every PHOTOFACT TV Folder) and test the Video, AGC and IF tubes—they check okay. Adjusting the AGC control produces a weak picture, but the contrast control has no effect.

Referring to the Standard Notation Schematic, there is a normal waveform at the Video grid. There is a weak signal at the plate. Voltages are high. In just minutes, you've pinpointed the trouble. When comparing resistance with the handy chart, rotating the contrast control varies the reading, but you find it's high. The answer: A cold solder joint at the center of the control. Trouble solved—in just minutes—with PHOTOFACT!

YOU EARN MORE DAILY when you have PHOTOFACT at your fingertips. It's your time-saving troubleshooting partner for everything that comes into your shop. Just reach for the easy-to-find PHOTOFACT Folder you need for any model. It provides *everything* you want—complete, uniform, authoritative.

You get: Famous Standard Notation Schematics packed with all the service details you need; full Photo Coverage of all chassis views; Complete Replacement Parts Lists; Tube Placement Diagrams; full Alignment Instructions; actual Waveform Photos; CircuiTrace® for printed boards; Alternate Tuner data; Terminal Identification and Connections; Disassembly Instructions

(including auto radio removal); Field-Servicing Notes; Dial Cord Stringing Diagrams; Changer and Recorder "Exploded Views"—plus dozens of other great features.

Own the complete PHOTOFACT Library—so you can instantly put your hands on all the quick help you need for any job on your bench! If you're not now a PHOTOFACT Library owner, you're more than paying for it in the time you lose every day. So take the *right* step to time-saving, profit-building servicing—see your Sams Distributor for details on an Easy-Buy PHOTOFACT Library and Standing Order Subscription—or send coupon today!

SEND COUPON

FREE FILE CABINETS



OWN YOUR PHOTOFACT LIBRARY THIS EASY-BUY WAY

More than pays for itself from the first day you put it into your shop! Now available to you on a Special Easy-Buy Deal: • **NO INTEREST • NO CARRYING CHARGES • ONLY \$10 DOWN • UP TO 30 MONTHS TO PAY.** And you get **FREE** file cabinets with your PHOTOFACT Library—so you have all you need for time-saving, money-making service work right at your fingertips. Get the PHOTOFACT Library details today.

START A STANDING ORDER SUBSCRIPTION TODAY—Keep up with the rapidly-increasing current model output! See your Sams Distributor or send coupon now for full details.

HOWARD W. SAMS & CO., INC.

Howard W. Sams & Co., Inc., Dept. 6-B3
4300 W. 62nd St., Indianapolis 6, Indiana

- Send full information on Easy-Buy Plan
- Enter my Photofact Standing Order Subscription

My Distributor is: _____

Shop Name _____

Attn. _____

Address _____

City _____ Zone _____ State _____

Available from all authorized ARCO distributors



Arcolytic®

1401 Values... The largest selection of exact replacement twist-mount & tubular electrolytics

■ 99.99% high purity aluminum foil electrolytics at no extra cost! ■ Choose from stock any single, dual, triple or quadruple capacitance-voltage combination for replacement in television, radio, and other electronic equipment ■ Made to withstand high ripple and high surge voltages ■ Designed for 85°C high temperature operation ■ Greater shelf and operating life because only premium grade ingredients are used ■ Built and tested to meet EIA Specification RS-154 ■ Individually packaged with mounting plates for your convenience ■ Unconditionally Guaranteed.

ARCO electronics inc. ELECTROLYTIC DIVISION
 Community Drive, Great Neck, New York • HUnter 7-0500
 Branches: Dallas 7 Los Angeles 35

(Continued from page 12)

59 to 78%. On 20% the volume was the same, and on 15% the commercials were softer.

Spurred by more than 55 complaints monthly, the FCC requested the TV industry and the public to furnish the commission, before Jan. 28, facts to help shape regulations to relieve the situation. "Loud commercials" stated the FCC, "are not only contrary to the public interest, but . . . to the self-interest of broadcasters and advertisers."

Solid State Laser on Sale

General Electric Co. has announced prices on research samples of gallium arsenide lasers—the new semiconductors that emit light when stimulated with a current of electricity. The new light-emitting diodes

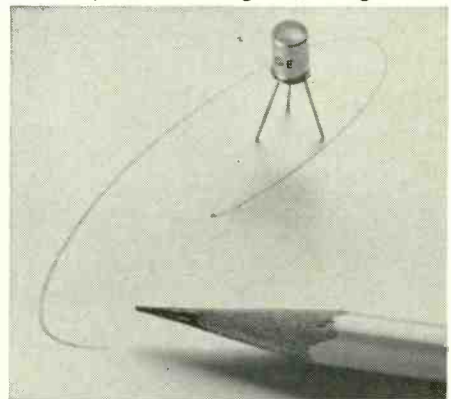

The new gallium arsenide laser.

are priced at \$130 for the noncoherent type, and \$1,300 for the coherent laser. Very heavy currents are applied to the diodes, causing them to emit a beam of infrared light—with a wavelength of about 8,400 angstroms—from the junction plane edges.

Underwater Doppler Radar Guides Surface Vessels

An underwater Doppler navigator, similar in action to the radar for planes described in the May 1962 issue of *Radio-Electronics*, page 8, has been developed by Janus Products, Inc., of Syosset, N. Y. The device, like its airborne counterpart, will provide the surface vessel or submarine with information on its true velocity and distance as well as its drift angle. Used with a standard marine compass, it informs the navigator instantly of his true heading and position. The radar uses an ultrasonic sonar wave instead of radio waves, to produce the echos from the bottom that give the information as to its rate and direction of travel.

Niels Bohr Dies

Prof. Niels Bohr, world-renowned atomic physicist, died Nov. 18. In 1913, Prof. Bohr discovered the role of the quantum in the structure of the atom, launching a life-

RADIO-ELECTRONICS

Find it and Fix it in 1/2 the time!

EASILY SOLVES "TOUGH DOGS"... INTERMITTENTS... ANY TV TROUBLE



MODEL
1076

TELEVISION ANALYST
BLACK & WHITE AND COLOR

TELEVISION ANALYST

By Easy Point-to-Point Signal Injection, You see the Trouble on the TV Screen and Correct it—Twice as Fast and Easy!

Simplified technique stops lost hours never recovered on "tough dogs", intermittents, and general TV troubleshooting. This one instrument, with its complete, accurate diagnosis, enables any serviceman to cut servicing time in half... service more TV sets in less time... satisfy more customers... and make more money.

With the Analyst, you inject your own TV signals at any time, at any point, while you watch the generated test pattern on the picture tube of the television set itself. This makes it quick and easy to isolate, pinpoint, and correct TV trouble in any stage throughout the video, audio, r.f., i.f., sync and sweep sections of black & white and color television sets—including intermittents. No external scope or waveform interpretation is needed. Checks any and all circuits—solves any performance problem. Gives you today's most valuable instrument in TV servicing—proved by thousands of professional servicemen everywhere.

Available on Budget Terms. As low as \$30.00 down.

Net, \$29995

SIMPLIFIES COLOR TV SERVICING, TOO

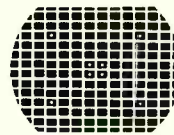

Enables you to troubleshoot and signal trace color circuits in color TV sets, or facilitate installation.

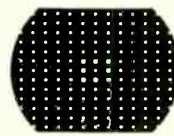

Generates white dot, crosshatch and color bar patterns on the TV screen for color TV convergence adjustments.

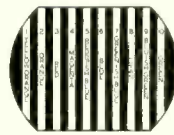

Generates full color rainbow display and color bar pattern to test color sync circuits, check range of hue control, align color demodulators. Demonstrates to customers correct color values.

Time-Saving, Money-Making Instruments Used by Professional Servicemen Everywhere



Model 960 Transistor
Radio Analyst



Model 360 V O Matic
Automatic VOM



Model 375 Dynamatic
Automatic VTVM



Model 700 Dyna-Quik
Tube Tester



Model 440 CRT
Rejuvenator Tester

See Your B&K Distributor
or Write for Catalog AP20-E



B & K MANUFACTURING CO.

Division of DYHASCAN CORPORATION

1801 W. BELLE PLAINE AVE. • CHICAGO 13, ILL.

Canada: Atlas Radio Corp., 50 Wingold, Toronto 19, Ont.

Export: Empire Exporters, 253 Broadway, New York 7, U.S.A.

EASY, ECONOMICAL, SURE way to LEARN ELECTRONICS

Gernsback's Basic Series Books

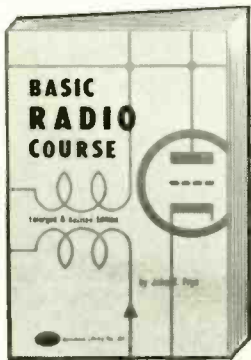

BASIC RADIO COURSE

Learn radio in this easy-to-understand, easy-to-read book. A perfect way to start your electronics career. #104—\$4.10

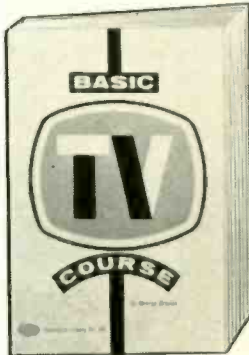

BASIC TV COURSE

Television as it is today. An excellent first reader in television electronics science. #105—\$4.10

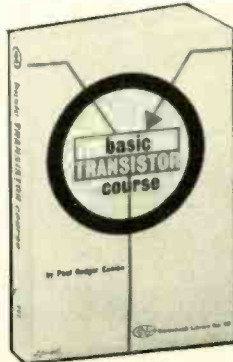

BASIC TRANSISTOR COURSE

THE book on transistor fundamentals. Must reading for electronics-minded men. #111—\$4.10

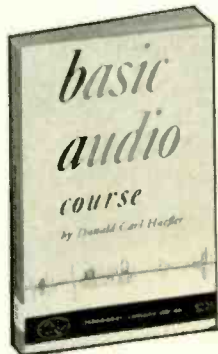

BASIC AUDIO COURSE

Audio high-fidelity systems from pre-amp to speaker. How and why audio systems work. #66—\$2.75

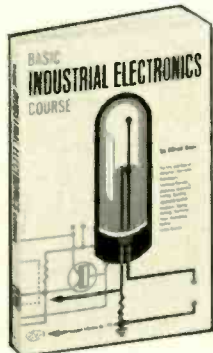

BASIC INDUSTRIAL ELECTRONICS COURSE

Just out! Breaks down complex industrial equipment into familiar devices. #109—\$4.10



BASIC MATH COURSE FOR ELECTRONICS

Takes math out of the dreary textbook world and into the exciting Electronics Age. #100—\$4.50

Buy Now From Your Electronic Parts Distributor or Fill Out Coupon:

-----10-DAY EXAMINATION-----

- 104 66
 105 109
 111 100

Remittance Must
Accompany
Order

Gernsback Library, Inc.
154 W. 14th St., New York 11, N. Y.
Name:
Address:
City:State:
Enclosed is \$.....

23RE

long study that paved the way for present-day knowledge of the atomic nucleus.

In 1922, Professor Bohr received the Nobel Prize in physics for "studies on the structure of atoms and the radiation emanating from them." He is responsible for the founding of the Institute of Theoretical Physics in Copenhagen.

R-E Readers Invited

The French Fédération National des Industries Electroniques invites readers of RADIO-ELECTRONICS to visit the Sixth International Exhibition of Electronic Components in Paris, one of the world's largest, at the Parc des Expositions, Porte de Versailles, Feb. 8-12, 1963. Show a copy of this issue of RADIO-ELECTRONICS to a hostess at the visitors' desk (Service d'Accueil du Salon) and she will give you a complimentary ticket to the exhibition.

CALENDAR OF EVENTS

9th National Symposium on Reliability and Quality Control, Jan. 21-24; Sheraton Palace Hotel, San Francisco, Calif.

12th Southwestern Electronic Conference (SWELCON), Jan. 27-31; Baker Hotel, Dallas, Texas.

4th Winter Convention on Military Electronics, Jan. 30-Feb. 1; Ambassador Hotel, Los Angeles, Calif.

Pacific Electronic Trade Show; Conference, Feb. 4-10; Statler Hilton Hotel; Show, Feb. 7-10; Shrine Exposition Hall, Los Angeles, Calif.

Washington High Fidelity Music Show, Feb. 8-10; Shoreham Hotel, Washington, D.C.

6th International Exhibition of Electronic Components, Feb. 8-12; Paris (Porte de Versailles), France

3rd Quantum Electronics Congress, Feb. 11-22; Unesco House and Parc de Exposition, Paris France.

International Solid State Circuits Conference, Feb. 20-22; Sheraton Hotel and University of Pennsylvania, Philadelphia, Pa.

International Sound Equipment Exhibition, Mar. 7-12; Palais D'Orsay, Paris, France.

Symposium on European Markets for Electronic Products, Electronic Industries Association, Mar. 19; Statler Hilton Hotel, Washington, D. C.

Electronics Industries Assoc. Spring Conference, Mar. 20-22; Statler Hilton Hotel, Washington, D. C.

90° Color Tube Delayed

RCA, in a telegram to manufacturing customers, reported that, due to technical difficulties encountered during pilot production, the new 90° color tubes expected about the beginning of the year would be held up for approximately 9 to 15 months. While RCA did not specify, rumors were that the difficulties were with color registration and convergence at the edges of the tube.

RCA Spokesmen expect that sales of color TV will run to more than 400,000 sets in 1963.

Some manufacturers were speculating on the possibility that, when RCA gets ready to deliver the tube, it may come out in rectangular rather than in round form. END

RADIO-ELECTRONICS

To assure **ADVANCEMENT** or to turn your hobby into a new and **PROFITABLE CAREER** in the fast growing field of **ELECTRONICS**

you should investigate the **NRI Home-Study Courses** in Industrial Electronics, Radio-TV Servicing, Radio-TV Communications

There is an immediate and growing need for trained Technicians in many branches of Electronics. In fact, four to seven trained Technicians are needed for every graduate engineer. Better than average jobs await you in the fast growing industry of the 1960's . . . offering high pay and prestige, interesting work and a bright future. Join the thousands of NRI graduates who have benefited from career opportunities in this Electronic Age. Mail the postage-free card today.

Turn Page for Facts on NRI Courses ▶

Qualify for Higher Pay

You must be *trained* to qualify for higher earnings and advancement. Whichever branch of Electronics you select, you'll find that NRI training is the time-proved way to get into this interesting and fast growing industry.



Training Equipment Included

When you learn Electronics through NRI you use scientifically developed "learn-by-practice" methods. At no extra cost, NRI sends special equipment that gives actual experience, makes theory you learn come to life in an easy-to-grasp, interesting manner. You perform a wide variety of experiments working with basic circuits and components. All equipment is yours to keep.



Oldest and Largest School

For nearly half a century, NRI has featured Electronics training, progressing from Radio and Television servicing and communications to Industrial and Military Electronics. As the oldest and largest home-study school of its kind, NRI can supply training at reasonable cost. Monthly payment plans. Take the first step toward a successful career now. Mail postage-free card. Get NRI CATALOG without cost or obligation. **National Radio Institute, Washington 16, D. C.**

Cut Out and Mail—No Stamp Needed



NATIONAL RADIO INSTITUTE
Washington 16, D. C. RE

Please send me your Electronic, Radio-TV catalog without cost or obligation. I am interested in course checked below. (No salesman will call. PLEASE PRINT.)

- | | |
|----------------------------------------------------|--------------------------------------------------|
| <input type="checkbox"/> Industrial Electronics | <input type="checkbox"/> FCC License |
| <input type="checkbox"/> Radio-TV Servicing | <input type="checkbox"/> Mobile Communications |
| <input type="checkbox"/> Math for Electronics | <input type="checkbox"/> Aircraft Communications |
| <input type="checkbox"/> Communications (Complete) | <input type="checkbox"/> Marine Communications |

Name _____ Age _____

Address _____

City _____ Zone _____ State _____

ACCREDITED MEMBER NATIONAL HOME STUDY COUNCIL

Approved for Veteran's under Korean GI Bill

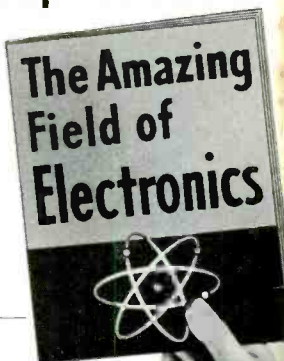

PICK THE CAREER YOU WANT IN THE WONDERFUL FIELD OF ELECTRONICS TRAIN AT HOME WITH THE LEADER

INDUSTRIAL ELECTRONICS



Prepare for a career as an Electronic Technician in industry, business, government, the military, with this NRI course in Electronics—Principles, Practices, Maintenance. Computers, telemetry, automation, missiles, rockets all employ the same basic principles . . . and that is what this NRI course stresses with illustrated lessons, special training equipment.

TELEVISION-RADIO SERVICING (INCLUDES COLOR TV)



NRI's time-tested course in Servicing not only trains you to fix radios, TV sets, hi-fi, etc., but also shows you how to earn spare-time money starting soon after enrolling. Fast growth in number of sets, color-TV, stereo, means money-making opportunities in your own spare-time or full-time business or working for someone else. Special training equipment included.

TV-RADIO COMMUNICATIONS



In the NRI Communications course you get *actual experience* as NRI prepares you for your choice of Communications fields and an FCC License. Commercial methods and techniques of Radio and TV Broadcasting; teletype; facsimile; microwave; radar; mobile and marine radio; navigation devices; FM stereo multiplexing are some of the subjects covered. You work with special training equipment.

FCC COMMERCIAL LICENSE



For men with Radio-TV experience who want to operate or service transmitting equipment used in broadcasting, aviation, marine, microwave, facsimile or mobile communications. A Service Technician is *required by law* to have an FCC License to work on C-Band, other transmitting equipment. From Simple Circuits to Broadcast Operation, this new NRI course trains you quickly for your Government FCC examinations.

← SEE OTHER SIDE →

ALSO: Special courses in Mobile Communications; Aircraft Communications and Guidance; Marine Communications; Math for Electronics.

Today, a career in Electronics offers unlimited opportunity. Job counselors advise, "For an interesting career, get into Electronics." The National Association of Manufacturers says, "There is no more interesting and challenging occupation in American industry."

When you train for a career in Electronics through NRI home-study methods your home becomes your classroom, and you the only student. You pick your own study hours, study when you want, as long as you want. No need to give up your job or go away to school. And there are no special requirements of previous Electronics experience or education. Train with the leader. Your NRI training is backed by nearly 50 years of success. Mail the postage-free card. National Radio Institute, Washington 16, D.C.

FIRST CLASS
PERMIT
NO. 20-R
(Sec. 34.9, P.L.&R.)
Washington, D.C.

BUSINESS REPLY MAIL
NO POSTAGE STAMP NECESSARY IF MAILED IN THE UNITED STATES

POSTAGE WILL BE PAID BY

NRI  **National Radio Institute**
3939 Wisconsin Avenue
Washington 16, D.C.



← MAIL POSTAGE-FREE CARD NOW

Correspondence



Letter from the Editor

Dear Readers:

Your Service Editor wishes to apologize for the error in the article "Use Your Scope" on pages 68-73 of the December issue. During one of his occasional flashes of stupidity, he gave the figures for *peak* voltage when what he actually meant was *peak-to-peak* voltage: 1.414 instead of 2.828, which is correct. The correct formula for this is, as he very definitely knows *now*, peak-to-peak voltages = rms voltage multiplied by 2.828. He has promised to watch out for this in the future. (Only the fact that another writer, in the same issue of another leading electronics magazine, made *exactly the same error*, saved him from some very drastic action by the Editor!)

Service Editor JACK DARR
RADIO-ELECTRONICS

We Were Hypnotized

Dear Editor:

The article in December 1962 (page 48) on an electronic switch for automobile starting illustrates part of the difficulty of our modern age, where complexity for the sake of complexity has become almost a rule. The sole purpose of three transistors, sundry resistors, capacitors and a heat sink is to switch the ignition coil from the regular battery to an auxiliary battery when the starting motor is actuated. This could be done much more simply by using a single-pole double-throw electromechanical relay.

The relay would be less expensive; a separate quick-start switch would not be necessary; problems of insulation, space, mounting and motor heat would be reduced, and the system could be used for 6-volt or 12-volt cars with either positive or negative grounds.

A more general use of Occam's razor is indicated. PAUL L. ESMAY
Custer, S. D.

[Apparently we were hypnotized by the glamor of electronics. The idea of a relay did not even occur to our Associate Editor, who installed it and tested it for a week, and even went to extra trouble to modify his negative-ground circuitry to work with the equipment. An engineer friend, just after World War II, complained that the glamor of electronics was so great that he had extreme difficulty persuading

manufacturers that honest iron and copper were still useful. Possibly the transistor is introducing a new semiconductor glamor age?—Editor]

Another Solution

Dear Editor:

Reading in the December issue the description of a device under the title "Start Your Car Fast" (page 48), I was fascinated by the simple, yet so efficient idea. In fact, after analyzing the circuit

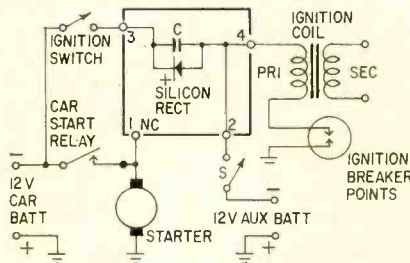

I came to the conclusion that similar results can be achieved with a circuit even more simple. How about this one?

Atlanta, Ga. S. LIFSHITZ

[Some seven letters were received—one of them from Commander Smithey, author of our first transistorized auto ignition article—supporting the position of Mr. Lifshitz and Mr. Esmay, above. Some showed diagrams, and others would have been happy with a simple manual switch.—Editor]

What Kind of License?

Dear Editor:

Several years ago, when I was an officer of ESFETA (Empire State Federation of Electronic Technicians Associations), I supported the ESFETA license bill, as I was led to believe that the State Education Department was to participate in the program. Later, I found this was not to be so, and resigned from organized service so that I could alert independent service technicians.

I am definitely in favor of a good license law that will raise the standards of the industry and protect the consumer. But when the law is so written that a man obtaining his license under the grandfather clause (without examination) can become an administrator of the law and even participate in the drawing up of examinations, you have a very inferior law.

I am not against people already in TV service getting a license under the grandfather clause, as I know this is the necessary requirement; *but I am against the law being so written that such a man can also serve on the board of administration.*

Another point that should be included in any good license legislation is several grades of licenses. This will provide an incentive for practicing technicians to keep abreast of new developments in their field. MELVIN COHEN
Hudson Falls, N. Y. END

a THORENS combination competition can't beat!



THORENS TD-121

Convertible 4-Speed Turntable
combined with

THORENS BTD-12S 12 INCH
Professional Mounted Tone Arm

The TD-121 gives you *all* the main features you'll find in the famous Thorens TD-124 at a big saving to you! TD-121's smooth-running, nonmagnetic table — a rugged, man-sized table that none of the lightweight can touch — assures rumble-free, wow-free performance. You get Thorens double drive — belt *plus* idler — for complete motor isolation. And many, many more features.

Factory mounted on a Thorens arm board, the BTD-12S tone-arm is an outstanding example of Swiss precision craftsmanship. Thorens engineers came up with an exclusive cueing device that saves records, protects costly high-compliance cartridges. And, although compact, the BTD-12S gives you less than 0.5°/inch tracking error — better than many 16" arms!

Why settle for less than the best? Go to your franchised Thorens dealer. See, hear, and compare this combination with any others. We're sure you'll end up with a far better music system and have the proud knowledge you own the best — Thorens.

TD-121 — \$85 net. BTD-12S — \$50 net.

THORENS  DIVISION

ELPA MARKETING INDUSTRIES, Inc.
New Hyde Park, N. Y.

Canada: Tri-Tel Associates Ltd., Willowdale, Ont.

UNCOMPROMISING ENGINEERING CREATES THE BEST BUY... EICO

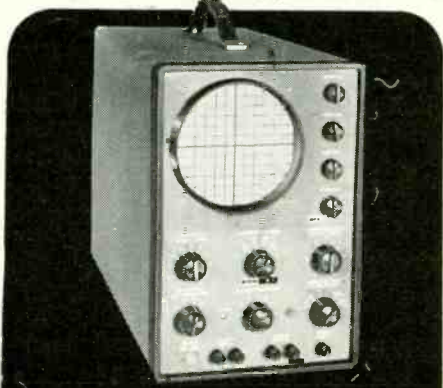

**NEW ADVANCED GENERAL PURPOSE
5" OSCILLOSCOPE #427**

Kit \$69.95 Wired \$109.95

Vertical amplifier with 3 push-pull stages, direct coupled throughout; 4-position, frequency-compensated V input attenuator; internal calibrating voltage. Recurrent sweeps from 10cps-100kc in 4 overlapping ranges; choice of int. +, -, 60cps, or ext. sync; fully automatic sync. operation; full retrace blanking. Intensity, focus and astigmatism controls on panel. Sharp, clean, non-blooming trace. Instantaneous; drift-free positioning. Convenient direct plate connections. V amp: 10mv p-p/cm sens.; 1a1 dc-500kc, -6db at 1mc; 1 meg input Z. H amp: 0.5V p-p/cm sens.; 2cps-450kc flat response; 10 meg input Z.



AC VTVM & AMPLIFIER #250
Kit \$49.95 Wired \$79.95

Highly sensitive, reliable AC VTVM & wideband amplifier. Measures 100 microvolts to 300V in 12 ranges; 10c-600kc ± 0 db response, 10 meg-ohms input impedance, ± 3 % accuracy. Wide-band amplifier switch-controlled for external use; 8c-800kc response, 5VRMS output, 5K ohms output impedance, gain control, noise -40 db. Frame-grid triode cathode follower input circuit, freq.-compensated input attenuator, cathode circuit attenuator. Regulated power supply.

AC VTVM #255 Kit \$44.95 Wired \$72.95
All the precise VTVM facilities of the #250 less external use of the wide-band amplifier.



AC VOLT-WATT METER #261*
Kit \$49.95 Wired \$79.95

AC voltmeter & load-compensated audio watt-meter of unique quality. Measures AC voltages from 1mv to 1000V in 11 ranges, power from .015mw to 150W in 7 ranges, across standard loads from 4 to 600 ohms. Tapped power resistor load (4, 8, 16 and 600 ohms) handles up to 80W on 8 ohms and 40W on other taps; Switch to external load up to 150W. Meter automatically compensated for any load selected, internal or external, to provide single watt scale.

*Formerly designated as #260.



VACUUM TUBE VOLTMETER #222

Complete with exclusive dual-purpose Uni-Probe® (U. S. Pat.)

Kit \$27.95 Wired \$42.95

Entirely electronic, direct reading measurement of resistance, and AC & DC to 1500V in 5 ranges. May be calibrated without removal from cabinet. Complete electronic overload protection, plus fuse, 1% precision ceramic resistors. Exclusive AC/DC Uni-Probe® selects DC or AC-Ohms. DC voltmeter input impedance 11 megohms, accuracy ± 3 %. AC voltmeter input impedance 1 megohm, accuracy ± 5 %. Ohmmeter 0.2 ohms to 1000 megohms in 5 ranges.



IN-CIRCUIT CAPACITOR TESTER #955

Kit \$19.95 Wired \$39.95

Tests capacitors in the circuit without unsoldering. Checks for shorts, (even in the presence of as little as 1 ohm shunt resistance). Checks open units (as little as 5MMF in the circuit). Measures capacitance with ± 10 % accuracy between 0.1mf and 50mf. Measures RC product, convertible into dissipation or power factor. Utilizes electron-ray tube EM84/6FG6 with sharp bar pattern. Line adjust control permits maximum sensitivity regardless of line voltage variations.



TRANSISTOR & CIRCUIT TESTER #680

Kit \$25.95 Wired \$39.95

Measures ICEO, ICBO & DC β directly, AC β indirectly, without charts or special settings—plus all dc volts, currents & resistances needed to service transistor equipment. Battery powered. 50 μ A, 3 $\frac{1}{2}$ " face meter movement provides sensitivity & scale length necessary for accuracy. Built-in 20,000GV VOM facilities free your other test equipment.



Extra-Low
Ripple

**6 & 12 VOLT
BATTERY ELIMINATOR & CHARGER #1064**
Kit \$45.95 Wired \$54.95

Heavy-duty 2-ranges for operating any mobile radio & transceiver including transistor or "hybrid" types. Also usable as charger for either 6 or 12 volt batteries. Variable transformer provides continuous output adjustment. 2 meters simultaneously observe output voltage and current. Ratings: 0-8V: 10A continuous, 20A intermittent; 0-16V: 6A cont., 10A interm. AC ripple: 0-16V range: 0.3% @ 2A, 1% @ 6A. Heavy-duty selenium rectifiers, & automatic reset overload relay.

**METERED VARIABLE
AUTO-TRANSFORMER AC BENCH SUPPLIES**



#1073: 3A rating Kit \$35.95 Wired \$47.95
#1078: 7 $\frac{1}{2}$ A rating Kit \$42.95 Wired \$54.95

For study of components under varying line conditions. Delivers any voltage up to 140VAC with linear variation of output throughout entire range. Smooth rotary brush-tap controlled by panel dial, Highly efficient variable toroidal core design. Auto-transformer. No waveform distortion or voltage drop from no-load to full load. Separate output ammeter & output voltmeter.



TUBE TESTER ADAPTOR #610

Kit \$5.95 Wired \$11.95

Adapts EICO models 625 or 666 tube testers for testing the following new tube types: nuvistor 5 pin; nuvistor 7 pin; novar; 10 pin miniature; compactron; 12 pin. Included are roll-chart supplements for both 625 and 666 models.

EICO

EICO ELECTRONIC INSTRUMENT CO., INC.
3300 NO. BLVD., L.I.C. 1, N. Y.

EICO, 3300 N. Blvd., L.I.C. 1, N.Y.

C-2

Send free 32-page catalog & Distributor's name.

Send Free Schematic of Model No. _____

Send new 36-page GUIDEBOOK TO HI-FI for which I enclose 25c for postage & handling.

Name _____

Address _____

City _____ Zone _____ State _____

Add 3% in West.

Over 2 MILLION EICO instruments in use.
Most EICO Dealers offer budget terms.

Listen to the EICO Hour, WABC-FM, N. Y. 95.5 MC, Mon.-Fri., 7:15-8 P.M.
Export Dept., Roburn Agencies Inc., 431 Greenwich St., New York 13

HUMAN ELECTRONIC TRANSMITTERS

... Doctors Will Soon Treat Patients by Remote Control ...

IN THE early 30's, Dr. K. Ogino and Prof. Dr. Hermann Knaus published their epoch-making discoveries on what is now known as the "rhythm of sterility and fertility in women." Before 1930, it was widely held that fertilization can occur at any time. Not so, stated the Ogino-Knaus team. Only if intercourse took place *shortly before, shortly after or during* ovulation—the monthly release of the female egg—a period of at most three days, could conception occur. As a rule, women would remain sterile at all other times during the menstrual cycle.

It was also found that at the exact time of ovulation the woman's temperature increases slightly, about 0.4° F. Most women, however, are not aware of this, nor do they feel the onset of ovulation.

Last November a new and very practical electronic feature of ovulation detection was announced by the Human Factors Society in New York, a professional organization of engineers, psychologists, researchers and other scientists. They work on various systems and equipment that people can operate most effectively.

Dr. Alvin Singer, of the American Electronic Laboratories of Colmar, Pa., reported a new device to the society: an improved electronic temperature recorder. It is a miniature transmitter mounted on the rim of a pessary (a pessary is a device worn in the woman's vagina, usually as a support for a weak or displaced womb). It does not interfere with ovulation or menstruation. Because of recent miniaturization, the electronic transmitter, with its temperature device and a tiny battery that lasts a year, is in fact much smaller than the pessary itself. They cause no discomfort to the woman wearer.

As Dr. Singer described it, the woman's internal temperature is broadcast continuously on a short-wave frequency. The signal is picked up by a nearby receiver. Then a steady recording of the basic temperature is made. When ovulation occurs, the temperature rises slightly. The recorder can then automatically sound an aural signal or alarm, notifying the woman of the exact time when ovulation occurred.

Dr. Singer also stated that in cases of difficulty in fertilization, a couple could be advised to have intercourse at the start of ovulation, the best time to achieve pregnancy.

He also reported that if intercourse takes place at the moment of ovulation, the chances for creating a male child increase by a factor of 3. On the other hand, intercourse 12 to 24 hours *before* ovulation will greatly increase the chances of begetting a female child.

Some scientists, however, have some reservations on this method of sex determination.

The Electronic Patient

In our present economy, there is a serious shortage of doctors. It is an almost impossible problem for doctors to visit all bedridden patients in person. It takes no great imagination to project this situation into the year 2000. *If doctors were to continue in their present routine, it is patent*

that they could not possibly visit one in ten patients. The result: an increase in deaths due to the impossibility of treating patients in time.

What then is the solution? Last July the present writer published this account of his opinion:

Long before the end of this century, electronic techniques will have changed doctors' routines; they will have completely revolutionized our present concept of doctor-patient relations.

This is the way we foresee the great change. The coming revolution is based on two important recent electronic developments and breakthroughs: *microminiaturization and millimeter waves.*

In the future, doctors will equip their patients with a *medical wrist band* that looks somewhat like a present-day wrist watch. Completely transistorized. It is in reality a radio transmitter which automatically sends out impulses every half hour. These are then recorded on a *microtape* at the doctor's office or his laboratory.

This is what the *mediwristrecorder* does: Every 30 minutes, it gives the patient's heartbeat. On the hour or half hour, the patient places his hand with the recorder over his chest, to transmit the rate of respiration, too. If breathing is labored, or if there is coughing, these facts are faithfully recorded. Temperature is recorded at the same time. Before 2000 a.d., it will be possible for a patient to transmit a good electrocardiogram, as well as an electroencephalogram, via the mediwristrecorder, too, simply by placing it in various positions on the body. Without going into too many medical-electronic technicalities, there will be many other tests, such as blood tests, blood pressure and allergy tests that can be made for various illnesses by using special wristrecorders.

You may ask, "How can such a small wristrecorder make such a multiplicity of tests and transmit them at a distance?"

The answer lies in one word: microminiaturization. It is possible right now to make *transistors and other electronic components so small you need a microscope to see them.* Hence we will soon have an incredible array of instrumentation in a cubic inch of space.

With the fully microminiaturized mediwristrecorder, the doctor can treat dozens of patients, often without leaving his office. He will make his rounds of calls *not in person, but over the phone.* After looking at a patient's radio-transmitted record, he will know exactly how to treat and prescribe for him. Of course, if the patient becomes seriously ill, the doctor will go to his bedside in person. But the point is that rarely will too many patients urgently require a personal visit at the same time.

Using millimeter waves, it is possible to have various frequencies, one for each patient. If that proves impractical, each wrist transmitter can be equipped with a timing device so that it transmits its signals only on certain periods of each hour. Thus if a doctor has, say, ten electronic patients, each

(Continued on page 114)

imagination plus

Plus what? Specialized service on auto radios, fixed-price policy, accessible location, low rent — these add up to success in servicing

By JACK L. BRAYTON*

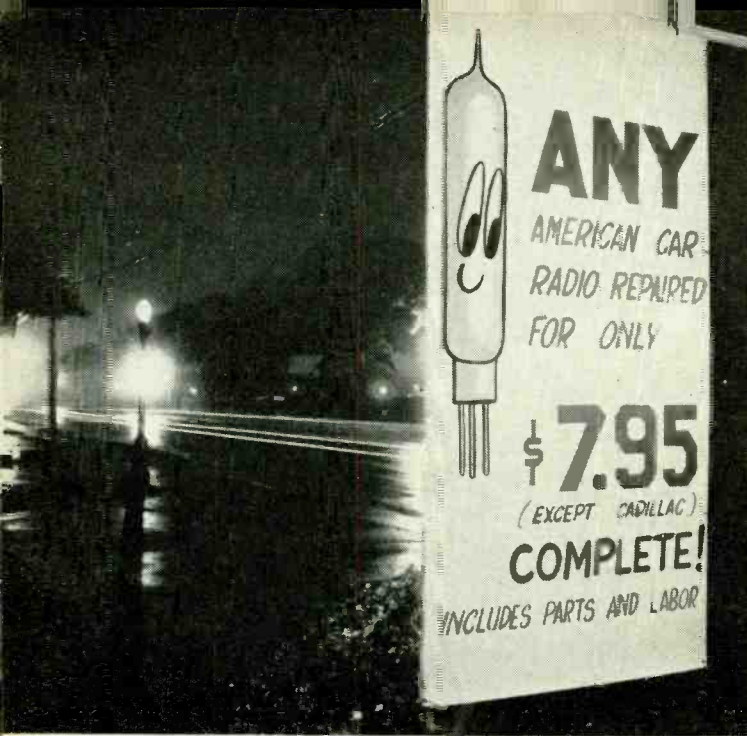

United Radio and this sign sit right on a 4-lane thoroughfare.

THERE HAS BEEN NO REALLY NEW METHOD of selling radio-TV service since the fad of service contracts ended with public disgust. But a short time ago I did run across a really new idea—a small concern called United Radio. Doug Smith, the owner of United Radio, is a young man full of imagination, foresight and a desire to get ahead.

Instead of merely flinging his doors open to the public and waiting for customers to rush to him, Doug investigated, sought advice and constantly poured fresh ideas into his business. Now he can complete effectively with shops several times his size. Doug puts it: "I offer something no one else does. That means

that I reap bigger dividends and my customers receive better service."

What's so unusual about Doug's business? Top on the list is *specialization*. He repairs only American car radios. Second, he repairs *any* American car radio, regardless of the trouble, for \$7.95. Cadillac is the one exception. Third, he issues a written, 30-day unconditional guarantee with each repair job. This means that *any* trouble that develops within the 30-day period will be fixed at absolutely no cost to the customer.

Read on and you will see that this is not the crazy harebrained scheme it sounds, but rather a well planned and

successful method of conducting a service business without the usual harassments of not having standard pricing, of dealing with people who can't understand why the service bill is \$20, of dealing with people who have no concept of what overhead is, and last, but far from least, of dealing with people who want something for nothing.

Imagination first

His reply to the question of how he got started: "When I first got the idea, I didn't have any information to back me up and, of course, no reference material. All I had was an idea which I thought to be good."

Having only the idea and some inexpensive equipment as assets, Doug rented what used to be the office of a construction firm well off the main streets in East Lansing, Mich. A very poor location in every respect, but the rent was only \$10 a month and, since Doug only intended to deal with car lots in his first experiment, the poor location didn't matter very much.

After setting up shop and establishing an arbitrary price of \$5.75 for the complete repair of any American car radio, Doug solicited the local used-car lots. With 48 in the immediate area, he had no trouble getting a small volume of radios. The next 90 days Doug spent collecting data on the cost of parts per radio, number of radios serviced under the guarantee and the time consumed in the repairs.

"From a profit point of view," Doug says, "these 90 days were fruitless. But I learned a great deal from the data I collected. Also, I learned what tools and inventory were needed.

"At this point, I teamed up with another guy, John Leavitt. John was good on promotion and making personal con-

Doug's shop. Notice its compact efficiency.

* Photos by Russ Flaughter.

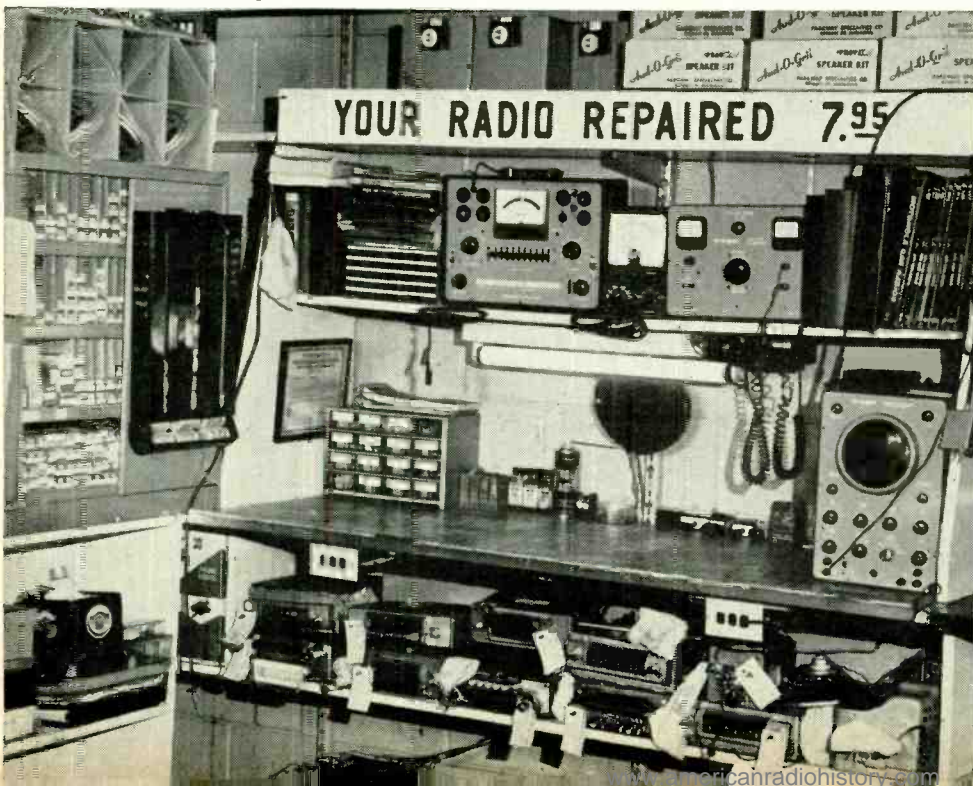

Having the correct tools at hand speeds up the type of work shown here.

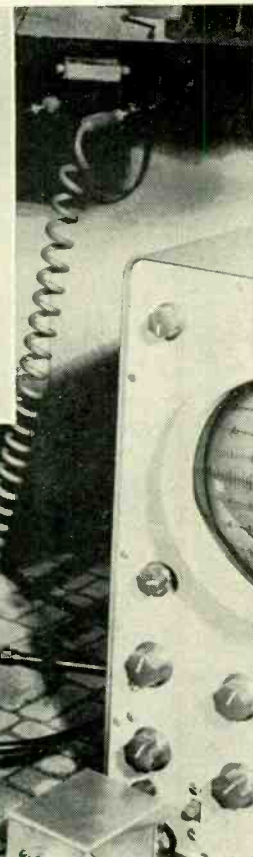
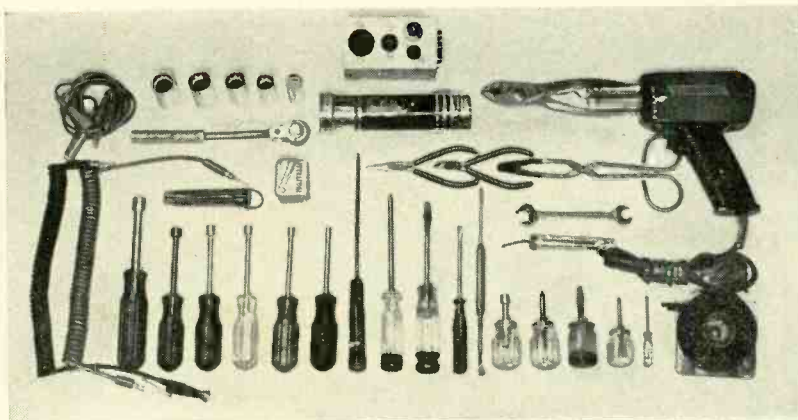

tacts with the car lots. Together we laid out our plans in detail. Now a good location became important. Our problems in selecting the location were:

1. To get it as close to as many car lots as possible.
2. To make it a place easily found by the general public.
3. To get near a heavy flow of traffic.
4. To get a place that could be driven into so that bad weather would not hamper servicing.
5. To pay a minimum rent.

As stiff as these requirements were, Doug and John found a place that met them, this time in Lansing, Mich. Hence, United Radio is presently located within a pleasant-looking and progressive service station. "This is the only place that met our requirements," Doug says, "and gave us these advantages:

1. It's located on a busy thoroughfare —4-lane, one-way traffic.
2. The car to be serviced can be driven into the garage in bad weather.
3. An air hoist is available for lifting the cars to facilitate servicing antennas.
4. Rent is still at an absolute minimum.
5. Business is picked up from the station and, of course, vice versa."

After finding a suitable location, Doug proceeded to set up the shop and John began the advertising campaign. The advertising consisted of a display ad once a week in the *State News* and the *State Journal*. Posters were put up in almost every place that had anything at all to do with automobiles. Postcards were mailed. A week of radio advertisements and an attractive sign, and they were in business.

After the initial promotion, John left the business and Doug took complete charge. That was the beginning, but only the beginning. The real work of making it go still lay ahead.

And now the plus

"Successful operation depends on four things," according to Doug.

1. Top speed and accuracy in servicing.
2. Top-quality servicing to reduce to a minimum the number of callbacks.
3. A volume of radios.
4. Public acceptance of the idea.

Let us take these things one at a time and see how he handles them. First of all, his servicing methods are very thorough and very exact. For instance, he knows that the rear mounting nuts of a radio are either $\frac{7}{16}$ or $\frac{3}{8}$ inch. Both sizes being on the same wrench, he carries only the open-end wrench with him. Also, Doug knows that there are only four main sizes of front mounting nuts and, therefore, he carries only the $\frac{3}{4}$ -, $\frac{1}{2}$ -, $\frac{5}{8}$ - and $\frac{9}{16}$ -inch deep sockets.

Also carried is a $\frac{1}{2}$ -inch deep socket, but it is rarely used. A set of nut drivers, two sizes of stubby Phillips, one stubby clutch-head, one stubby flat blade, and, of course, pliers and side cutters complete the removal and reinstallation kit. "By specialization I've reduced to a minimum the tools and inventory required," Doug points out. "This, of course, increases efficiency while reducing the overhead."

How he does it

Doug explains his service procedure: "After listening to the customer's complaint, only a few brief tests are needed to tell me whether the radio needs to be removed or may be serviced in the car."

"Of course, I check the fuse first. If

it's good, I check for power at the hot side of the lead coming to the fuse. If there is power at this point, I pull the set. If the power is not there, then I continue to check the wiring in the car.

"If the fuse is bad and the set is a vibrator type, then it's pulled. The buffer capacitor and vibrator being the most common causes, these will be changed while the customer waits. I never change one without the other. At first I did, but found that I had too many callbacks. If it is something other than the buffer capacitor and vibrator, the bench procedure will disclose this very quickly.

"If the set has a blown fuse and is not a vibrator type, I simply replace the fuse. The fuse in a transistor-powered radio is overloaded by as much as twice its value when the set is first turned on and for this reason it blows, in many models, every 5 or 6 months. However, I always ask the customer to bring it back if it blows again within a short period. Incorrect transistor bias can also cause the fuse to blow in too short a period. Of course, there is no charge when only the fuse is blown.

"If the new fuse blows immediately, the set is transferred to the bench.

No sound, tubes light

"For this problem, I pull the tubes in succession, starting at the output, and listen for a click in the speaker. When I come to a dead stage, I replace the suspected tube. If sound is not restored, I remove the radio.

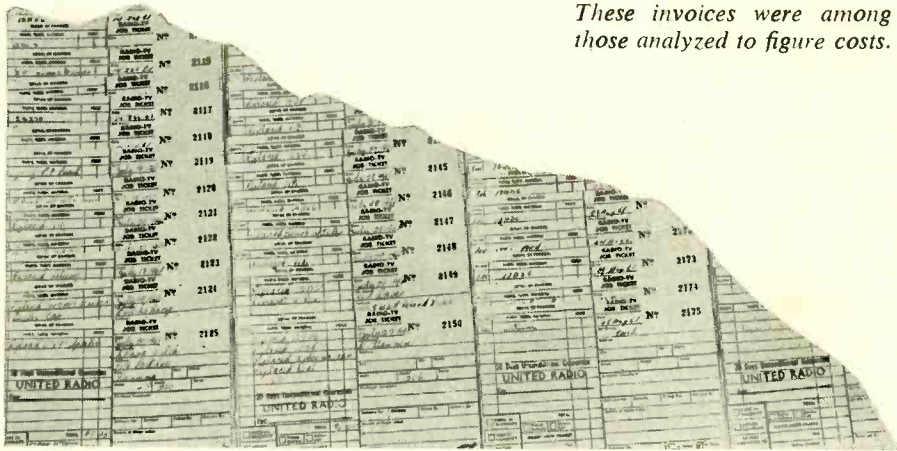

These invoices were among those analyzed to figure costs.

"With a transistor-powered radio, you can tell a good deal about it simply by turning it on. When you turn it on, listen for a pop in the speaker. If the pop is there, the speaker is good and is connected. Also the set is receiving power and the output transformer is good. On the other hand, if the pop is not heard, the set is not receiving power, or the speaker is disconnected, or the windings on the output transformer are defective.

Weak or distorted

"The radio is always removed for this fault, with only two exceptions:

1. If the distortion is caused by a warped or loose speaker cone.
2. If the set is weak because of a poor antenna connection. When this happens, a loud rushing noise is heard, even on local stations."

"The reason I pull it," Doug states, "is that even though it may be caused by a single weak tube, too often a weak or distorted radio has a combination of faults that show up only through a careful stage-to-stage check of the entire set.

Cutting in and out

"With this complaint I check the power, antenna and the speaker leads. If this doesn't reveal the fault, the radio is removed for a thorough check.

Automatic tuning defective

"In the automobile, I replace only the relay control tube (12AU7, 12AL8, etc.). If this does not cure the trouble, the radio goes to the bench."

"Certainly these rules are not infallible," Doug comments, "but they are the ones I have found most effective and time-saving. Nor do they cover every situation. There are not and cannot be any completely cut-and-dried rules for something as flexible and changing as the service business. But a sound servicing procedure and policy applied with judgment will, in the long run, save time and money. I also feel that the customer is never impressed by a technician who spends more than a few minutes checking the radio before he

determines if it has to be removed."

On the bench

When the set goes to the bench for further troubleshooting, Doug removes both covers and lays out the schematic for it. After hooking the battery eliminator, antenna and speaker, if required, to the radio, Doug quickly checks each stage with the scope. He always uses the scope for bench checks.

"Although the scope I own is extremely inexpensive, I would be at a loss without it," Doug states. "By constantly using the oscilloscope a person becomes so proficient with it that very few troubles will elude him. A majority of the so-called 'dogs' become routine with the scope and a thorough knowledge of its traces. The vibrator, buffer, transformer and filter can all be checked accurately.

"A vibrator with burnt contacts or a high-resistance short in the buffer capacitor will show on the scope long before any voltage or current reading will indicate these faults. With an iron-clad guarantee such as ours, we have to spot these possible troubles before they become actual complaints."

In most cases, Doug checks the radio in this way while the customer waits, thus allowing him either to repair it on the spot or to give his client a definite and fairly accurate estimate of when it will be ready. Even i.f. transformers are replaced while the customer waits, provided Doug has them in stock. He gives three reasons for doing it this way: First, the customer appreciates this kind of service. Second, the customer has the required \$7.95 with him when he brings the radio in, but tomorrow he may decide that he has a better use for it elsewhere and the radio is left in the shop for a long while. Last, but far from least, space at United Radio is limited and it is not possible to store a large number of radios. "And besides," Doug says, "the radios under the bench don't do either the customer or myself any good."

So now you say, "OK, Doug has a good deal and has solved a lot of the

problems of servicing such as free estimate, credit, customer relations, etc. But now let's have some statistics. Let's see how he is really doing." Here goes.

I took a hundred of Doug's invoices numbered 2101 through 2200 and analyzed them to find the cost of parts per radio, type of work done, and the number of these radios returned under the guarantee.

The cost was figured at the straight wholesale price, although Doug receives several discounts by buying parts in the right quantities and shopping around before he buys, and the normal discount for cash. However, they vary from time to time so were not taken into consideration here.

The cost for parts per radio averaged \$1.82, which Doug says is about normal. However, it has been as low as \$1.31 and as high as \$2.85.

The percentage of radios returned for further service under the guarantee ran about 5%. The average cost of those serviced under the guarantee was 57¢, and fell sharply into five categories.

1. The printed circuit developed a bad connection.
2. A tube had failed.
3. The new part put in the first time had failed. (A small percentage of i.f. transformers failed.)
4. A dial light had burned out.
5. Miscellaneous; turn-signal noise on weak stations, dial cord broken, etc.

Public acceptance of the idea has been steady and rapid. "At first," Doug said, "I got only the dogs that had been circulated from shop to shop. But when I proved myself on the tough ones, word-of-mouth advertising did wonders. Actually, getting the tough ones at first helped me to formulate a very thorough service procedure. Of course, some radios still give me the run-around, but they are getting fewer."

Now let's look at it from the customer's viewpoint. First of all, it's worth \$7.95 to most people to have their radios repaired when the technician repairs, not only the main trouble, but puts the set into excellent condition.

Second, they know the price before they come in and need not worry whether they can afford it. Last of all, we come to Doug's main selling point, the 30-day guarantee, not only on his parts and his labor, but on the entire radio. This guarantee eliminates dissatisfied customers. If they are not satisfied in every respect, Doug will continue to repair the radio, at no additional charge, until no faults are to be found.

There may still be some who will say that it cannot work. But it is working, and very well for Doug Smith. His average earnings have been over \$100 a week. For a little one-man shop not working at its full capacity, this sounds, to me, like good business. END

A NEW SYSTEM OF TAPE RECORDING AND playback, introduced by Minnesota Mining & Manufacturing and Revere Camera Co., may do for tape recording what the long-playing record did for discs. The parallel is not accidental—the new system was developed by Dr. Peter Goldmark, head of CBS Laboratories, father of the long-playing record. (He described and demonstrated the prototype at the IRE convention in 1960.)

The most interesting feature of the new system is the tape cartridge. It is $3\frac{3}{4}$ inches square, less than $\frac{1}{2}$ inch thick and, unlike earlier tape cartridges, contains only one reel. Columbia Records has prepared a library of 48 stereo recordings as a start, and, of course, the user can buy blank tape to make his own recordings. Unlike conventional stereo tapes, the new ones have but two tracks. Playing time is 48 minutes per cartridge at $1\frac{1}{8}$ ips.

The tapes are stacked in a well, little pins on the top of each cartridge locking into the one above it to prevent displacement. As soon as each cartridge is played, it is rewound in roughly 1 minute and slid out to the side, permitting the next cartridge to fall into place. As many as 20 cartridges can be stacked, giving the listener 15 hours of uninterrupted music.

The second most important feature is the changer mechanism, which threads, plays, rewinds and changes cartridges automatically. When the PLAY button is depressed, the cartridge on the bottom of the stack falls into place in the well. A roller then presses against the tape leader through a slot in the cartridge. This leader is a heavy stiff length of polyester film. Pushed out through a slot in the cartridge, it travels across the playback head and into the takeup reel. At this point, the capstan grips the tape and it starts playing.

The rewind mechanism is triggered as the selection ends, and the tape is zipped back into the cartridge. The cartridge then slides into the bottom of an adjacent well and pushes up the stack of used cartridges.

A third important component of the system is the special tape that provides high-quality reproduction at a playing speed of $1\frac{1}{8}$ inches per second. To get quality equivalent to that on conventional tapes at $7\frac{1}{2}$ inches, the signal-to-noise ratio was improved 6 db over that of earlier tapes and high-frequency response bettered. This was done with a new oxide and binder. The tape is about $\frac{1}{4}$ inch wide, with an oxide coating of about $\frac{1}{4}$ mil thick, bonded onto a special 1-mil-thick, prestretched polyester base. It is said to be the first tape ever produced with a noise level lower than record hiss.

NEW automatic tape changer

Plays 15 hours



Another factor in quality recording is the head, which has a gap only $1\frac{1}{2}$ microns wide. Extremely high precision was necessary to design it for such a narrow gap, and for good separation between the two tracks on the narrow ($\frac{1}{4}$ -inch) tape.

Since this system depends on a number of interdependent factors, it is, of course, incompatible with any cartridge or open-reel system on the market. In appearance, however, it is simply another recording—playback machine, weighing about 32 pounds, containing dual record and playback preamps, main amplifiers and speakers, as well as jacks for extension speakers. It can

record either monophonically or in stereo from the speaker terminals of radios, phonos or TV sets, or from the tape outputs of hi-fi amplifiers and tuners.

The new unit is not cheap, carrying a suggested list price in the order of \$450. Prerecorded tapes would run between \$8 and \$10 depending on the types of program. Raw tapes for recording will be sold in 450-foot cartridges at a list price of \$4.75. A limited quantity of the new tape material will also be sold in regular $\frac{1}{4}$ -inch widths on conventional reels for professional use in making tape masters and similar applications.

END

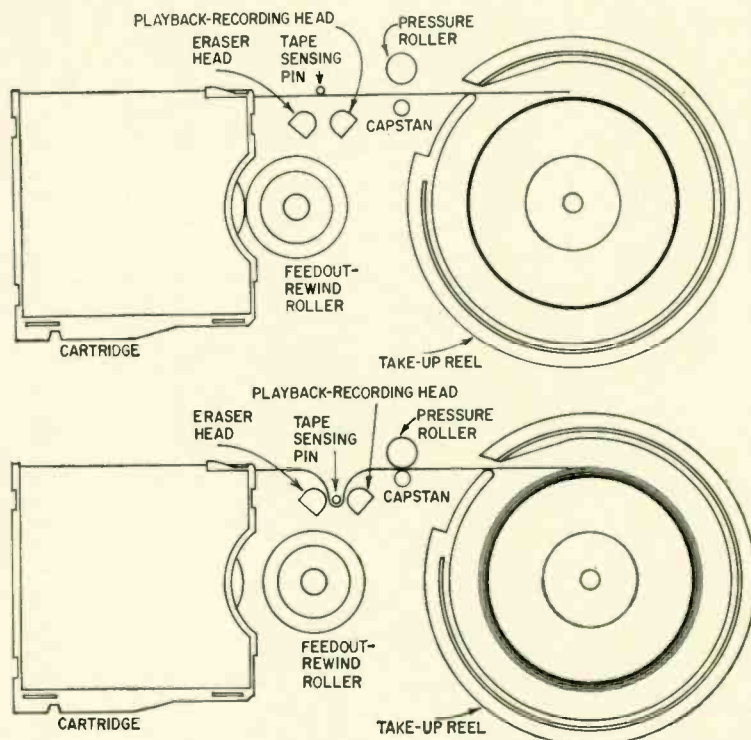

How the tape is threaded. Feedout (and rewind) roller pushes leader out into takeup reel, where it is gripped by pressure flanges. The capstan then pulls tape as tape-sensing pin brings it up against playback—recording head.

add STEREO to your FM with this simple ADAPTER

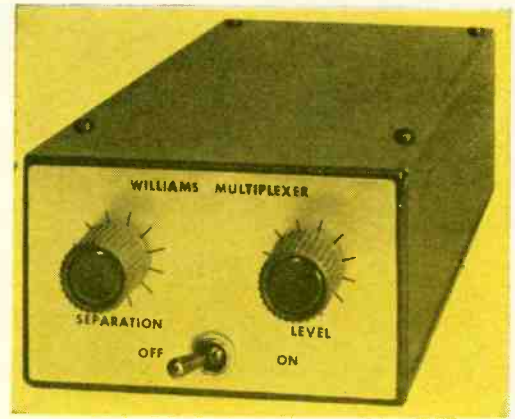

By DAVID A. WILLIAMS

8-transistor unit is easy to build; enhances your listening pleasure

This all-transistor adapter uses synchronous switching to separate the multiplex signal into left- and right-channel components. The detection system does not require any phase distorting filters, and the 38-kc subcarrier is a low-amplitude signal easy to keep out of the adapter's output.

Another advantage is this circuit's

ability to drive a set of stereo headphones without additional amplification. This makes it an economical, high-quality source of stereo for someone who does not already own a stereo system. The low output impedance also permits long connecting cables between the adapter output and a preamp or headphone input.

While the circuit appears complex, it is quite simple in most respects (Fig. 1). Q1, an emitter follower, provides the current gain to drive the adapter circuits without loading the tuner. Resulting input impedance is about 100,000 ohms. A LEVEL control permits adjusting volume of both channels without changing the level of the pilot carrier.

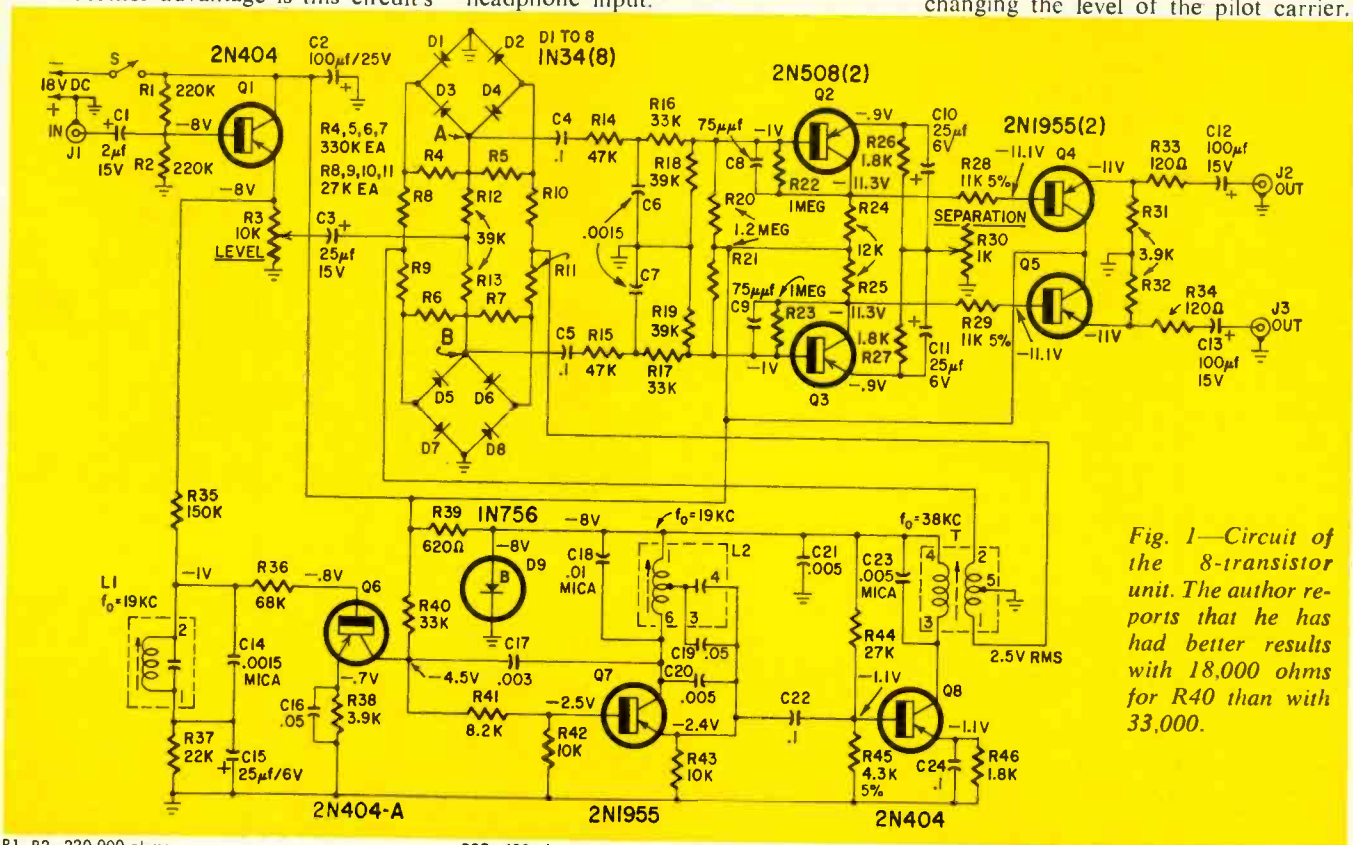

Fig. 1—Circuit of the 8-transistor unit. The author reports that he has had better results with 18,000 ohms for R40 than with 33,000.

- R1, R2—220,000 ohms
- R3—pot, 10,000 ohms, linear
- R4, R5, R6, R7—330,000 ohms (see text)
- R8, R9, R10, R11—27,000 ohms
- R12, R13—39,000 ohms
- R14, R15—47,000 ohms
- R16, R17, R40—33,000 ohms
- R18, R19—39,000 ohms
- R20, R21—1.2 megohms
- R22, R23—1 megohm
- R24, R25—12,000 ohms
- R26, R27, R46—1,800 ohms
- R28, R29—11,000 ohms, 5%
- R30—pot, 1,000 ohms, linear
- R31, R32, R38—3,900 ohms
- R33, R34—120 ohms
- R35—150,000 ohms
- R36—68,000 ohms
- R37—22K

- R39—620 ohms
 - R41—8,200 ohms
 - R42, R43—10,000 ohms
 - R44—27,000 ohms
 - R45—4,300 ohms, 5%
- All resistors 1/2-watt 10% unless noted
- C1—2 μ f, 15 volts, miniature electrolytic
 - C2—100 μ f, 25 volts, electrolytic
 - C3—25 μ f, 15 volts, miniature electrolytic
 - C4, C5, C22, C24—0.1 μ f
 - C6, C7—.0015 μ f
 - C8, C9—75 μ f
 - C10, C11, C15—25 μ f, 6 volts, miniature electrolytic
 - C12, C13—100 μ f, 15 volts, miniature electrolytic
 - C14—.0015 μ f, mica
 - C16, C19—.05 μ f
 - C17—.003 μ f
 - C18—.01 μ f, mica

- C20, C21—.005 μ f
 - C23—.005 μ f, mica
 - D1, D2, D3, D4, D5, D6, D7, D8—1N34
 - D9—1N756
 - J1, J2, J3—phono jacks
 - L1—Bandpass filter (Miller 1353 or equivalent)
 - L2—19-kc osc coil (Miller 1354 or equivalent)
 - Q1, Q8—2N404
 - Q2, Q3—2N508
 - Q4, Q5, Q7—2N1955
 - Q6—2N404-A
 - S—spst toggle switch
 - T—38-kc doubler output transformer (Miller 1355 or equivalent)
- Chassis, 5 x 8-inch perforated phenolic board
Case, 5 x 10 x 3-inch chassis box with 5 x 10-inch chassis bottom
Miscellaneous hardware

A considerable portion of the circuit is devoted to generating a stable, distortion-free, 38-kc subcarrier. Q6, a sync amplifier with a tuned base circuit, separates the 19-kc pilot from the composite signal. The tuned circuit helps prevent the 19-kc oscillator from synchronizing with anything but the pilot carrier.

A 1N756 Zener diode stabilizes the voltage on oscillator Q7 and doubler Q8. The .005- μ f capacitor shunting Q7 reduces the effect of internal capacitance variations caused by changes in ambient temperature. The two coils and transformer in the tuned circuits are standard J. W. Miller components which were designed for multiplex adapter circuits although not for this specific use.

The diode switching circuit is the most important part of the adapter in that it alone is responsible for separating the composite signal into its left and right components. As the 38-kc subcarrier alternately grounds points A and B, the voltage of the ungrounded point will follow the composite signal.

The type of diode used is not critical and 1N34's or equivalents will work well. The 330,000-ohm resistors compensate for differences in the back resistance of the diodes. With no input applied to the adapter the subcarrier at points A and B should be zero. Pad the 330,000-ohm resistors until this holds true. Since the amplitude of the subcarrier never exceeds that of the audio, it is almost completely removed by the de-emphasis network and no additional filtering is needed.

Following each output of the switching circuit is a de-emphasis network, an amplifier (Q2 and Q3) and an emitter follower (Q4 and Q5). The de-emphasis filters consist of the .0015- μ f capacitor and 47,000-ohm resistor in the amplifier base circuits and the 1-megohm and 75- μ f networks between collector and base. This provides a de-emphasis curve that is within 2 db of the standard over the useful audio ranges but is much sharper at 38 kc for better subcarrier attenuation.

The SEPARATION control is in the emitter circuits of Q2 and Q3. When it is set at minimum resistance there is no coupling between the emitters and the separation, while not zero, is greatly reduced. Increasing the resistance increases separation. Maximum separation is obtained with 300-400 ohms in the circuit. The exact setting depends on the adapter adjustments and other factors.

The emitter-follower output circuits have enough power to drive low-impedance headphones as well as conventional high-impedance amplifier inputs. The 120-ohm resistors limit loading when headphones are used.

The power supply voltage is not

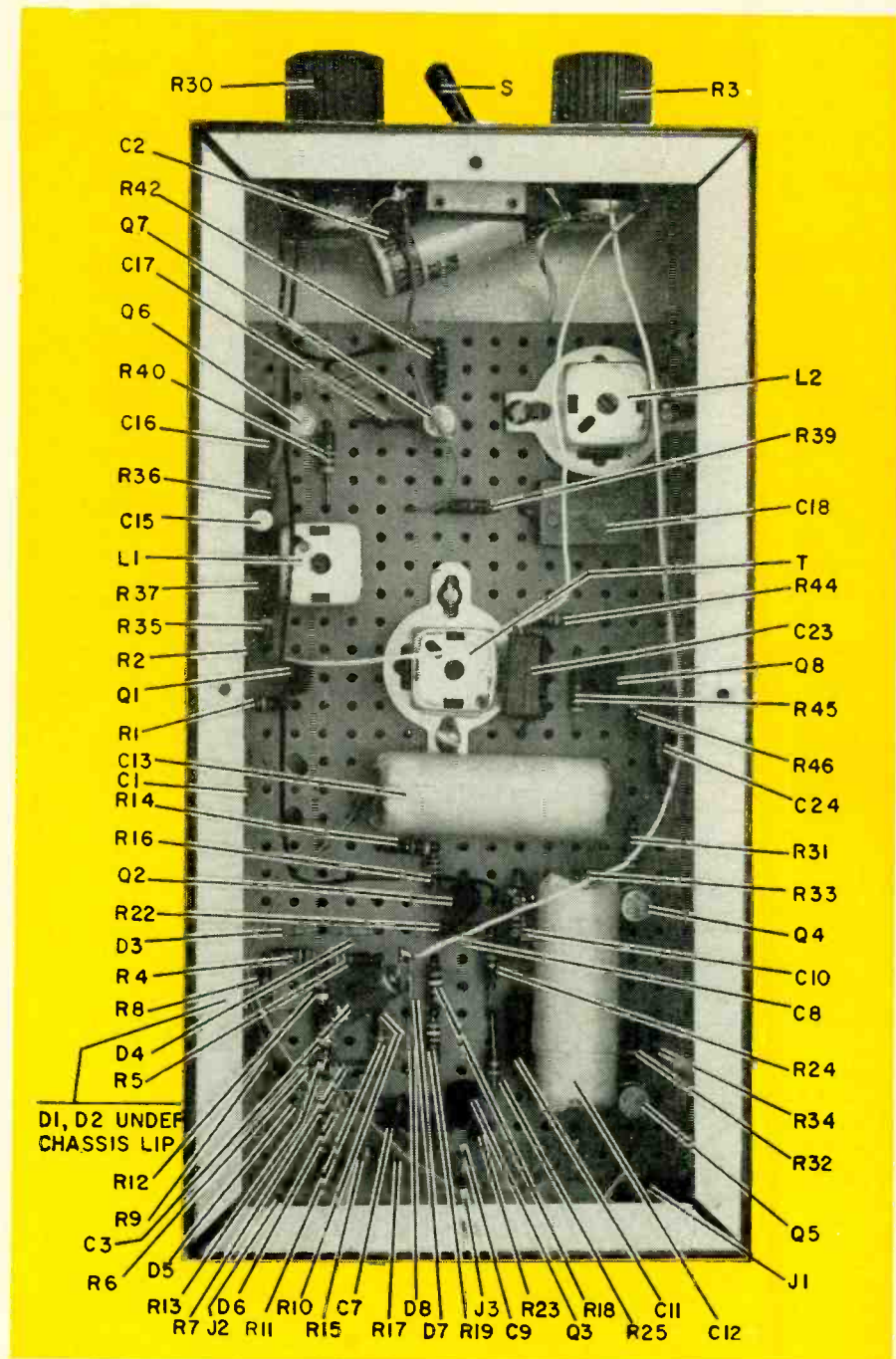

With the bottom of the case open it is easy to get at the phenolic chassis.

critical, but an upper limit is imposed by the rating of the transistors and a lower limit by the voltage regulator circuit. A good working range would be 15 to 22.5 volts. The current drain is 22 ma at 18 volts. A battery will last for a considerable period of time but an ac power supply is more desirable in the long run. Voltages on the schematic were measured with a vtvm. They are intended as a guide and may vary somewhat. Set the adapter's controls fully counterclockwise while measuring.

Construction is not especially critical, but you must protect the diodes and transistors from heat. My unit is laid out on a 5 x 8-inch piece of perforated circuit board which was later mounted in-

side a 5 x 10-inch chassis. The photos show the parts layout on the board.

The only alignment required is to adjust the tuned circuits to their resonant

BENCH



TESTED

This unit was carefully tested by Leonard Feldman, formerly of Crosby Teletronics. His report shows that separation and de-emphasis are satisfactory. The adapter will lock in on a stereo signal until the input to the unit drops to 0.2 volt. Since the average FM tuner recovers about 1 volt or so of composite signal for full limiting and full modulation, the adapter will lock in on a pilot carrier even if reception is 14 db below full limiting—Editor

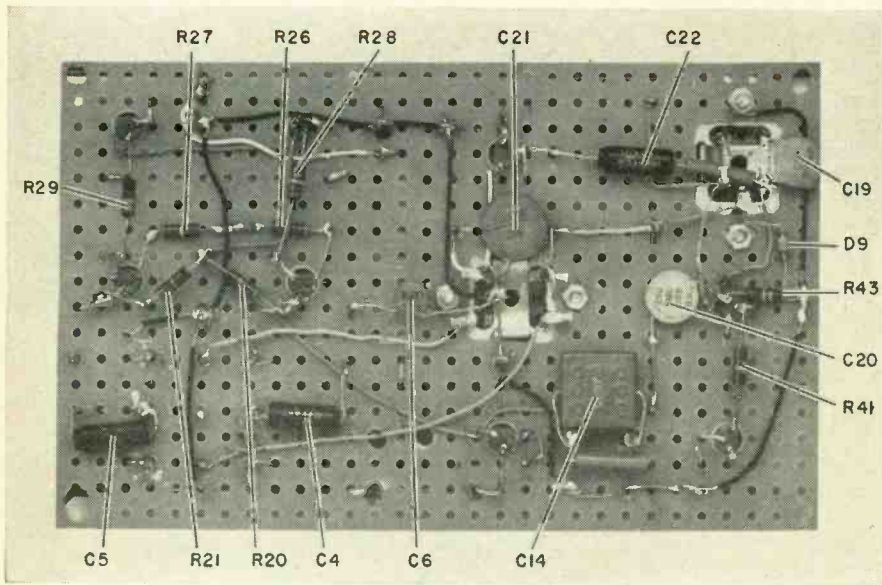

The other side of the chassis.

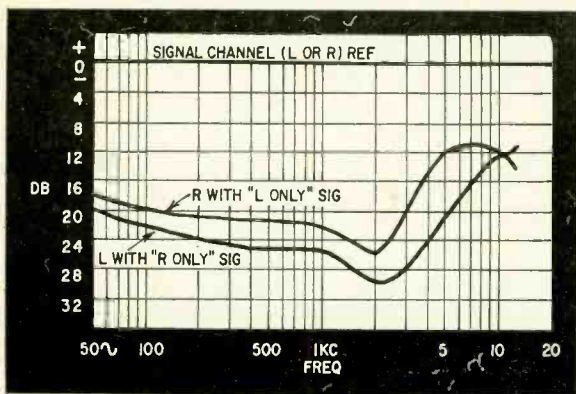
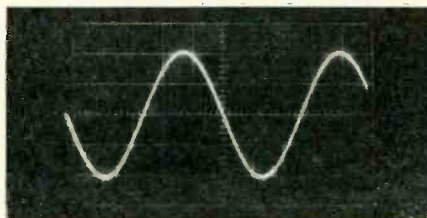
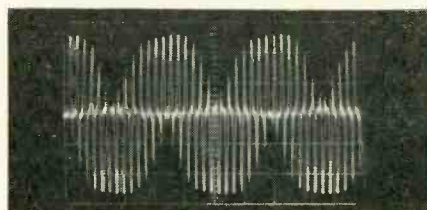
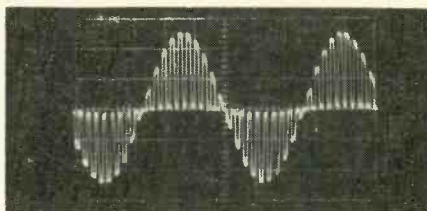
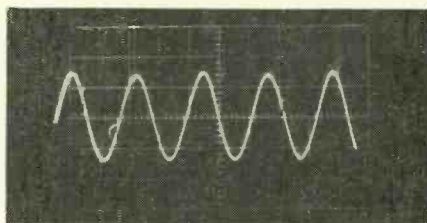
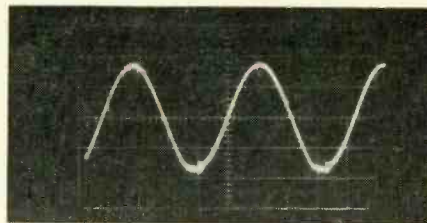

Fig. 2—Channel separation curves for the adapter.



Waveforms found in adapter: a—At emitter of 19-kc oscillator. b—38-kc subcarrier at one of points where it is applied to diode switching circuit. c—Signal at point A when single frequency of about 1.9-kc is applied to adapter input. d—Signal at point A when single frequency of about 41 kc is applied to adapter input. e—Signal at output with single frequency applied to input.

frequency. A signal generator and scope are helpful, but not necessary. Tune to a station transmitting stereo. If the oscillator is detuned, a beat tone will be heard. As the slug on the oscillator coil is tuned, the beat will disappear and separation will be heard. If the other two coils are peaked there should be three settings of the oscillator slug which give maximum separation. Leave the slug tuned to the one in the center. This adjustment is easiest when earphones are used.

The doubler may be tuned for maximum voltage at its output. If a scope or ac vtvm is available, sync amplifier Q6 may be tuned for maximum signal at its base. The voltage is too low at this

point for an ordinary vtvm. If no instruments are available, align the sync amplifier by listening for the point where the separation is affected as L1 is tuned. As the coil is tuned through resonance the separation will decrease or change sides. Leave the slug at this point and then go back to the oscillator and tune for maximum separation, making sure that it is still on the center maximum. Many stereo stations make their announcements on one channel only to aid in the adjustment of multiplex receivers.

One subject not mentioned so far is the suppression of SCA subcarriers. Theoretically, no filters are needed if the adaptor is linear; however, several other factors affect this including the bandwidth of the tuner, the level of modulation and the linearity of the transmitter. I was unable to find a station broadcasting both stereo and SCA programs. Some stations broadcasting SCA alone caused audible interference and some did not. Since there are few if any stations using both modes of transmission, no filter was included in this unit. An SCA filter circuit is provided (Fig. 3), should it be necessary. It is advisable that the filter be switched out when not needed to avoid any possible phase distortion.

One of the problems associated with

most transistor circuits is the tendency for transistor characteristics to change with temperature. This circuit has been stabilized to the point where it will operate from room temperature to above 120°F without loss of separation.

[To simplify construction, a labeled and drilled printed circuit board may be obtained for \$4.80 from David Williams, 26 N. Burgess Ave., Columbus 4, Ohio.]

END

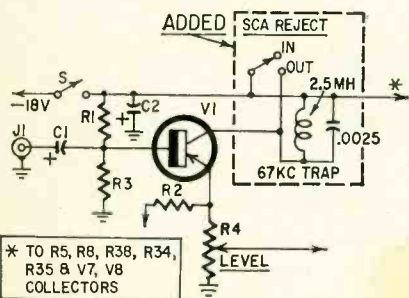

Fig. 3—Add a trap to the input stage if additional SCA suppression is needed.

What's Old

By **DICK BARRETT**

All the items shown are exhibits at the Cavalcade of Electronics, a collection of electronic equipment housed in one wing of the Perham Foundation's exhibit at New Almaden, Calif. A number of other exhibits appeared on page 35 of the August 1962 issue.



(Left) A collection of many early mercury rectifiers. In top row, partially hidden by cabinet upright, is a three-part rectifier patented by Steinmetz in 1915.

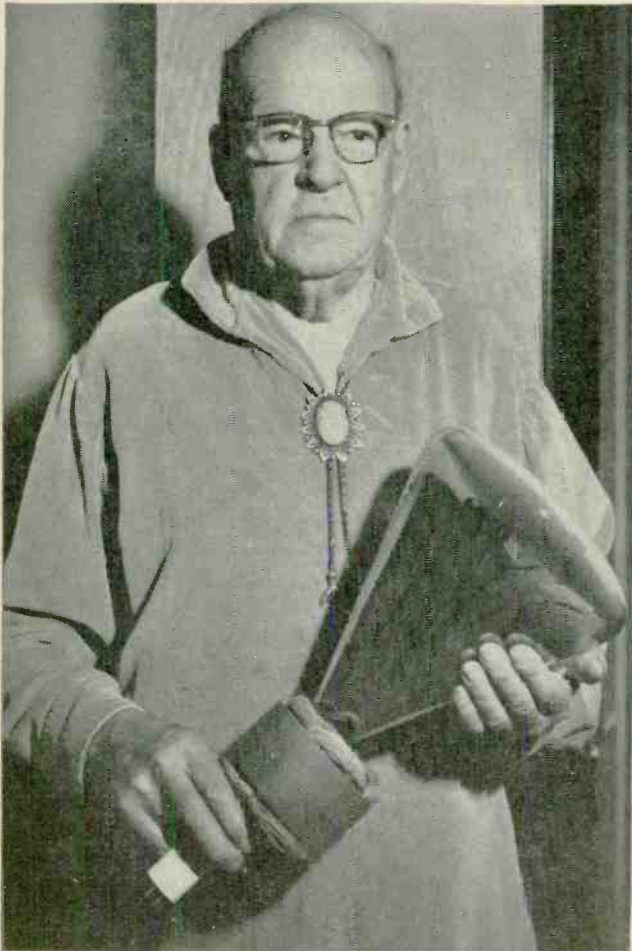

Douglas Perham holds early Farnsworth CRT. It was fabricated from a chemist's flask, the fluorescent screen being painted on the bottom and the electron gun welded into the neck.

This original de Forest triode was made in 1906. De Forest wrote in a letter in 1959: "Among the really rare relics you will see there [Perham Foundation exhibit] is one of the original three-electrode cylindrical-shaped tubes with a screw base."

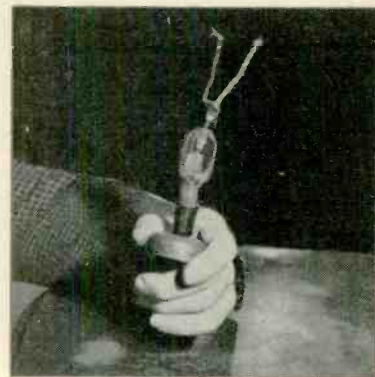

This exhibit was built by Ralph Heintz in 1928. It was to be used as evidence in a patent suit to show that the Heintz-Kaufman circuit was not the same as de Forest's and that at least four other researchers had produced oscillations with a three-element tube before de Forest.

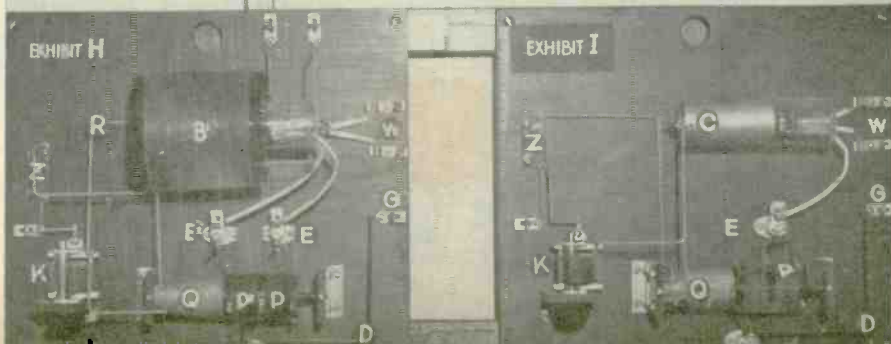
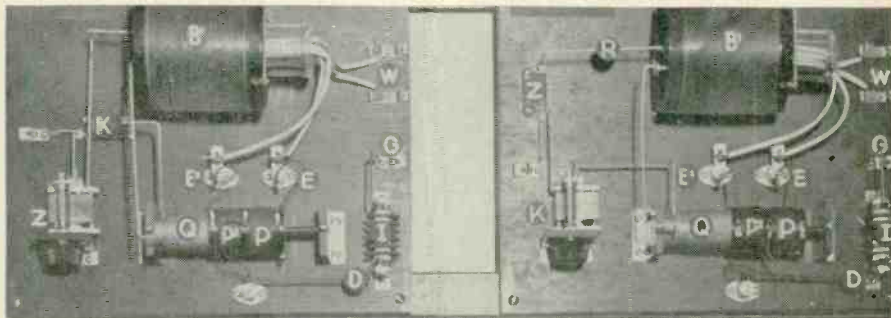

Try building this 3-transistor unit

audio voltmeter doubles as preamp



Battery-powered unit needs no line cord.

By DAVE STONE

The Trans-Audio voltmeter is an extremely useful piece of test equipment for the serious audio or hi-fi constructor, service technician or engineer. It is a portable, transistorized rms ac voltmeter that can measure signal levels from below 1 mv to 20 volts, over the audio-frequency spectrum. It can also be used as a general-purpose low-level preamp with a voltage gain of 10 into a high-impedance load, and a frequency response flat within 3 db between 20 and 20,000 cycles. The voltmeter has a minimum input impedance of approximately 50,000 ohms, and the amplifier section puts a maximum undistorted signal output of 1.5 volts peak into 50,000 ohms.

The test set is powered by a 6.5-volt mercury cell. Total current drain is

only 4 ma, so long battery life is assured.

The Trans-Audio voltmeter is a three-stage, common-emitter transistor amplifier driving a detector diode which feeds the indicating meter. R1 sets the minimum input impedance of the voltmeter for relatively light loading of the circuit to be measured. Resistors R2 through R11 form the voltage divider input for the voltage ranges selected by S1, the RMS VOLTS range switch.

The three stages are ordinary voltage amplifiers with each base biased with a resistor from base to ground and base to supply voltage. R24 and the voltage divider chain are V1's base bias resistors, R13 and R14 for V2, and R18 and R19 for V3.

V1 and V2 are 2N140 if transistors noted for their sensitivity and low-noise operation. V3, a 2N331 audio transistor, feeds the amplified signal to the 1N70 diode for rectification. The diode load consists of R22, CALIBRATION pot R23, and the 200- μ a meter. Switch S2 connects the amplified signal output to the diode-meter combination, or to AMPLIFIER OUTPUT jacks J3 and J4 for use as a straight voltage amplifier. It also switches the battery power on when turned to METER or AMPL.

Construction hints

Except for the voltage-divider resistances, mount all components on a 3 x 2½-inch perforated board. Mount R2 through R11 directly on S1. The photos show the amplifier board mount-

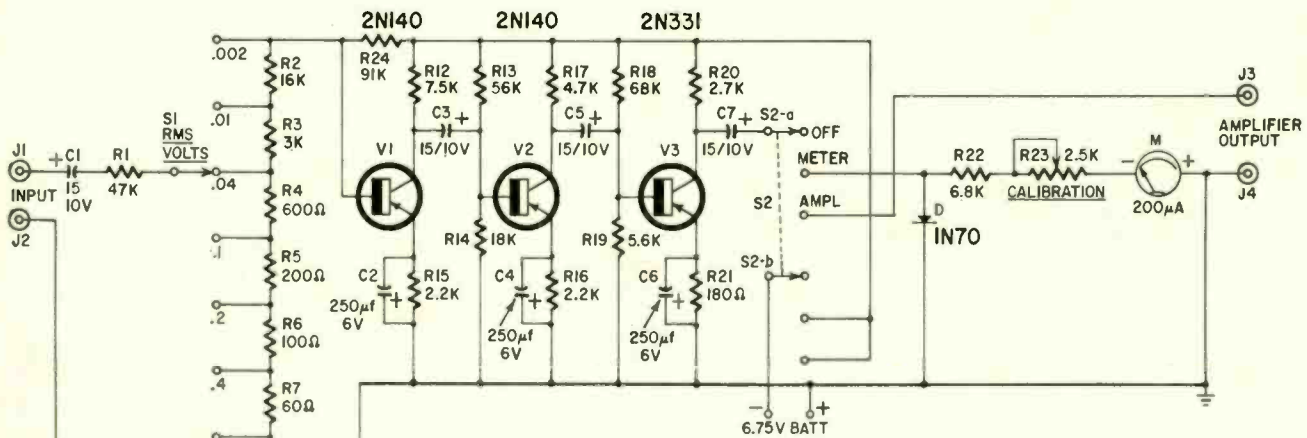

NOTE:—ALL ODD VALUE RESISTORS ARE SELECTED 10% UNITS. IF DESIRED USE 1% OR 5% TYPES

- R1—47,000 ohms
- *R2—16,000 ohms (selected 15,000-ohm 10% resistor)
- *R3—3,000 ohms (selected 2,700-ohm 10% resistor)
- *R4—600 ohms (two 300-ohm units in series)
- *R5—200 ohms (two 100-ohm units in series)
- *R6—100 ohms (selected 120-ohm 10% resistor)
- *R7—60 ohms (selected 56-ohm 10% resistor)
- *R8—30 ohms (selected 27-ohm 10% resistor)
- *R9—6 ohms (3 18-ohm units in parallel)
- R10, R11—2 ohms, 1%
- *R12—7,500 ohms (selected 6,800-ohm 10% resistor)
- R13—56,000 ohms
- R14—18,000 ohms
- R15, R16—2,200 ohms
- R17—4,700 ohms
- R18—68,000 ohms
- R19—5,600 ohms
- R20—2,700 ohms
- R21—180 ohms
- R22—6,800 ohms

- R23—pot, 2,500 ohms, wirewound, linear
- R24—91,000 ohms, 5%
- *NOTE: All resistors are ½-watt 10% units. Those used in the voltage divider are selected to be close to the indicated values. For greater accuracy, use 1% resistors in the divider.
- C1, C3, C5, C7—15 μ f, 10 volts, tantalum (Mallory TAS15-10 or equivalent)
- C2, C4, C6—250 μ f, 6 volts, miniature electrolytics (Sproge TE1105 or equivalent)
- BATT—6.75 volts, mercury (Mallory TR-135R)
- D—1N70
- J1, J2, J3, J4—3-way binding posts
- M—Meter, 200 μ a, dc
- S1—single-pole 11-position rotary switch
- S2—double-pole 3-position rotary switch
- V1, V2—2N140
- V3—2N331
- Case, to suit
- Miscellaneous hardware

Circuit of the Trans-Audio meter.

ed above the input jacks and alongside S1. If another layout is used, keep J1, J2, C1, R1, S1 and V1 as close to each other as possible to minimize hum pickup. Also, wire all grounds to one common chassis connection.

Placement of S2, J3, J4, the meter and battery is not critical. In this unit, the panel components were mounted and interconnected, the amplifier board wired, and final assembly completed by mounting the amplifier board and wiring the few remaining connections. My meter is housed in a 7 x 5 x 2-inch aluminum chassis. An aluminum cover forms the back. It is absolutely necessary to enclose the instrument completely in a metal case to keep stray hum fields from the input stage.

C2, C4 and C6 are miniature tantalum capacitors. They can be replaced with conventional electrolytics if you wish. Since the electrolytics will be larger, arrange the layout to keep the capacitors close to their respective stages for the shortest connections to the emitter. On the other hand, C3, C5 and C7 must be good-quality tantalum units.

The accuracy of the Trans-Audio voltmeter depends upon the accuracy of the range voltage-divider resistances. The range resistors in this unit were selected from 10% units measured on a resistance bridge and provide an overall instrument accuracy of 5%. If 1% resistors are used, accuracy increases to 3% or better.

Calibration and use

After completing the unit, temporarily connect a milliammeter in series with the negative battery lead and turn S2 to the METER position. If the wiring is correct, the meter will indicate about 4-ma drain. If the current is appreciably higher, check the wiring for mistakes, wrong placement of the transistors in their sockets or defective transistors. When the correct current is obtained, rotate S1 to the .002-volt position and touch the hot side input jack (J1) with a finger or screwdriver. This will cause the meter to deflect full scale and indicate that all is well with the amplifier.

Obtain an audio signal generator and a standard accurate vtvm for calibration. Set the generator for 1,000 cycles, connect the vtvm to the generator's output jacks and adjust the output level for exactly 1 volt rms on the vtvm. Rotate the Trans-Audio RMS VOLTS selector to the 1-volt setting, turn S2 to METER and connect it across the generator's output jack. Adjust R23 for a full-scale reading, then check the other ranges by adjusting the output level of the generator. The 1-volt calibration will suffice for all ranges if resistance tolerances are close.

Applications

The Trans-Audio voltmeter can be

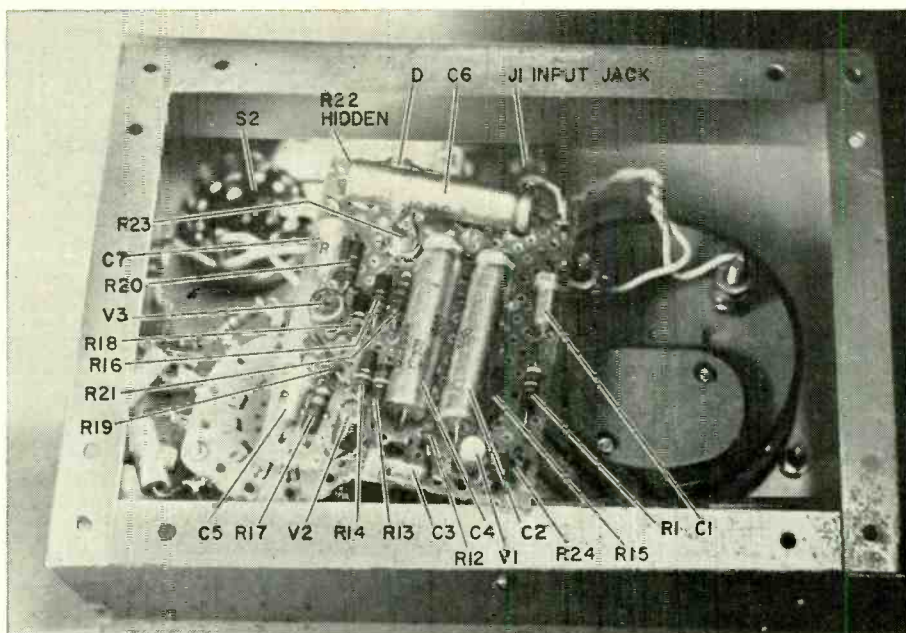

Parts layout on the phenolic chassis.

used wherever low-level audio signals are to be measured. It will measure the output of most cartridges and microphones, voltages across speaker voice coils, the levels across audio transmission lines, voltage gain per stage of audio amplifiers and many other similar values. If the voltmeter is used to measure an audio voltage in a circuit that also carries more than 100 volts dc, insert a 1- μ f 400-volt paper blocking capacitor in series with the input lead. For example, the blocking capacitor is needed when the voltmeter is used to measure an audio signal at the plate of a tube voltage amplifier fed by a 250-volt dc supply. It causes only a slight decrease in accuracy.

Use the unit as a low-level preamp by rotating S2 to the AMPL position. The amplifier output at J3, J4 can be

used to extend the sensitivity of an oscilloscope or drive a power amplifier, headphones or other similar units. The

BENCH

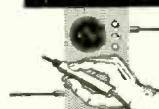

TESTED

This handy little ac vtvm measures all ac signals from below 1 mv to 20 volts. While not precisely flat over the entire audio range, errors are not large enough to cause trouble and are more than made up for by the portability of the unit. The unit is accurate within 5%. This is not the best possible accuracy, but only 10% tolerance components are used. If 1% resistors were used accuracy would increase proportionally.

RMS VOLTS range selector acts as an input attenuator in this application and sets the level of the input signal to provide an undistorted amplified output signal. END

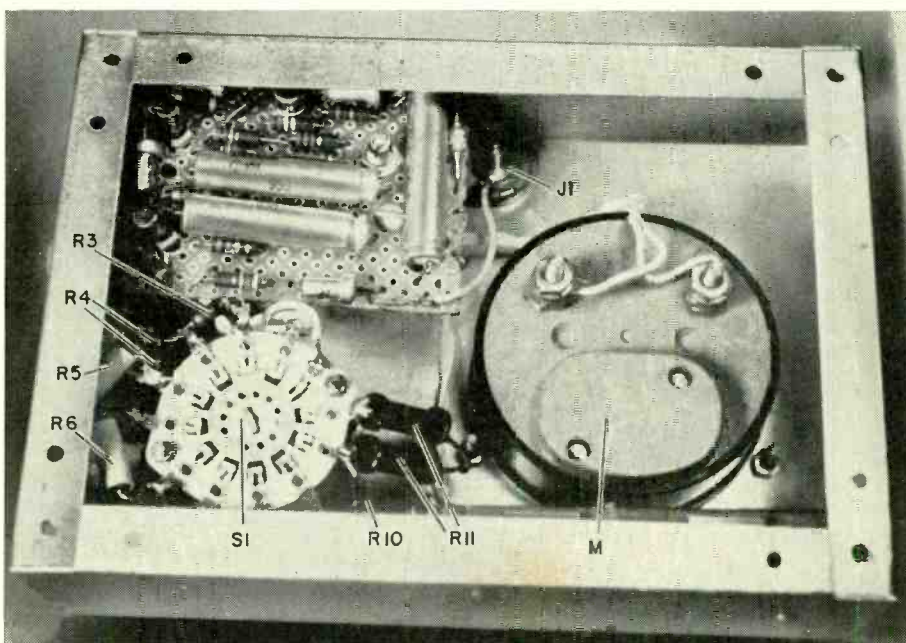

Look inside case shows where components are mounted.

➔ CB REPAIRS YOU CAN MAKE WITHOUT A LICENSE

By JACK DARR
SERVICE EDITOR

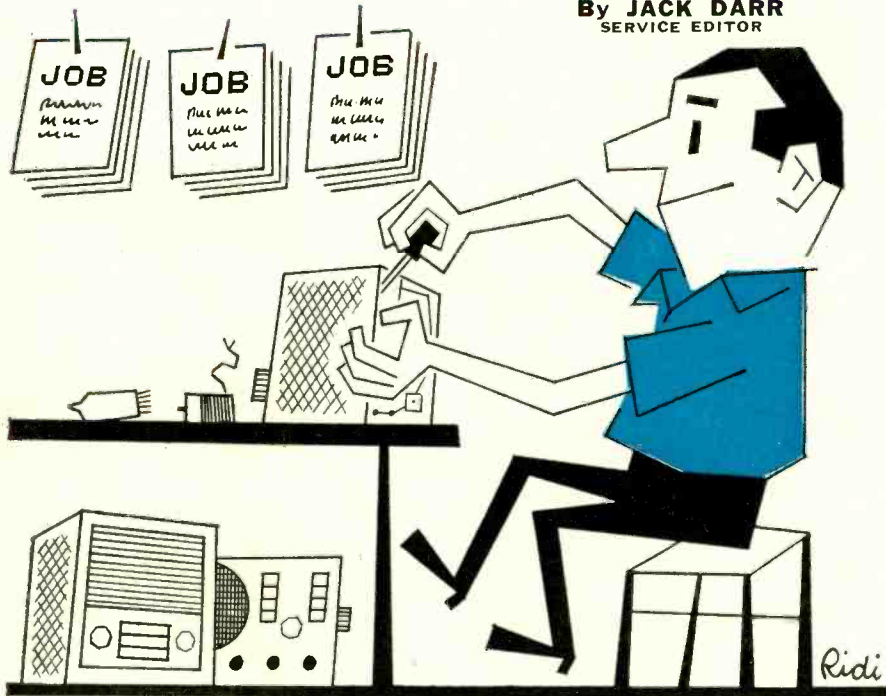

IT IS A VIOLATION OF THE FCC RULES FOR unlicensed persons to make "any adjustments which would affect the frequency or emission" of a Citizens-band transmitter. But there are a lot of service jobs that can be done. You can do anything necessary to the receiver and you can test the transmitter for rf out-

put and modulation.

The receivers are simply AM superhets. (In the better sets, that is. Some of the smaller jobs use superregenerative and other circuits.) Incidentally, Sams *Photofacts* now has service data for many on the more popular brands. The largest percentage of re-

ceivers are crystal-controlled. Some have conventional variable tuning and a switch for selecting adjustable tuning trimmers or crystals.

Receiver alignment

With low-power transmitters, receivers must be at maximum sensitivity at all times to provide good service. The i.f.'s are given in the service data. Use your standard signal generator and the vtvm on the avc for i.f. alignment, as in Fig. 1.

Most i.f. strips are pretty broad-band, and sweep alignment isn't too necessary. However, if you want, it can be done. Fig. 2 shows the setup and a typical i.f. response curve. You'll probably have to pull the crystal, and perhaps the rf amplifier tube, to get the curve to settle down.

Rf alignment

Rf alignment is a bit more critical, since it must be done at the carrier frequency, around 27 mc. To be sure that the system will work at maximum efficiency, all receivers and transmitters must be on *exactly* the same frequency. This is called "netting". So we need a signal on the right carrier frequency. A communications receiver covering the 27-mc band is handy here, but a fixed- or variable-tuned CB receiver can be used. Get a signal from the base station or other mobile station in the same system. Tune the signal generator to approximately this frequency, and couple it to the antenna of the test receiver.

While the signal is on the air, quickly zero-beat the signal generator against it. (Suggestion: with a dummy load hooked up, transmit an unmodulated carrier.) This makes it easier to

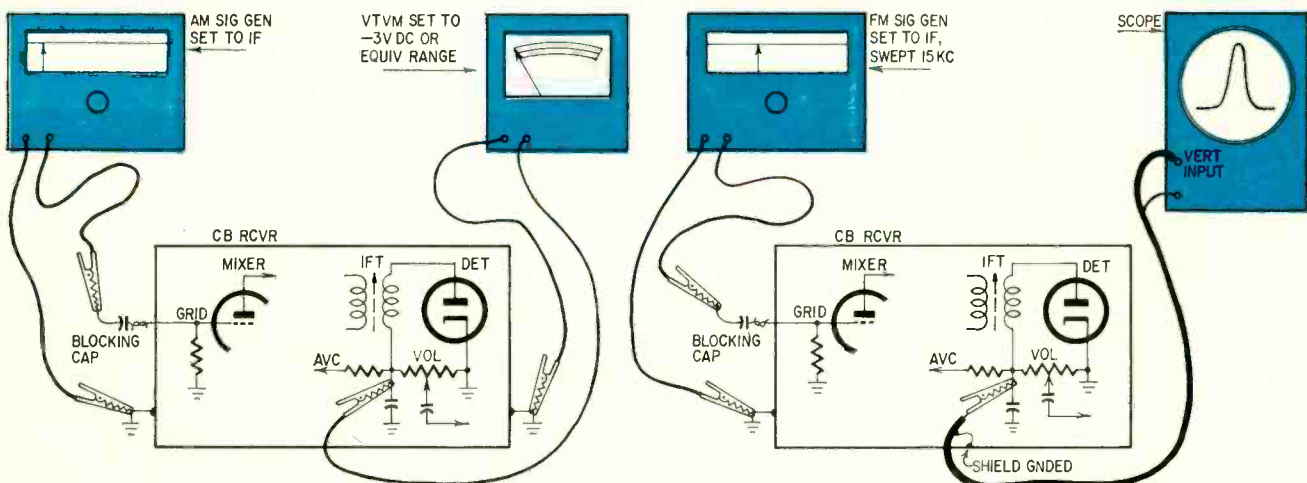

Fig. 1—Setup for aligning CB receivers with AM signal generator and vtvm. Set signal generator to i.f., vtvm to low negative dc volts scale. Tune i.f. transformers for maximum negative swing. Keep generator output down to make avc voltage read about 1 volt. Couple generator as loosely as possible to mixer grid.

Fig. 2—Setup for i.f. sweep alignment of CB receiver: After finishing AM alignment, hook up equipment as shown. You may have to remove crystal to avoid beats in the curve. Sweep rf stages by setting generator to carrier frequency. Feed signal to antenna terminal, keeping coupling loose. Best bet is to hook up regular antenna to receiver and radiate signal into it from piece of unshielded wire connected to signal generator output.

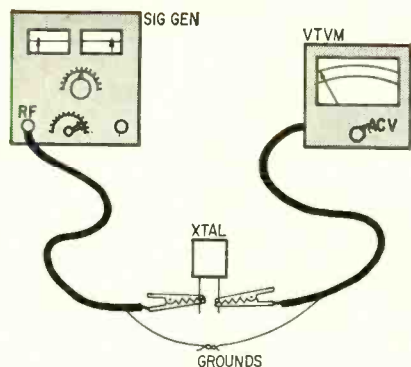

Fig. 3—Using signal generator and vtvm to check a crystal.

zero-beat the signal generator. Once this is set up, it can be used to align all the receivers in a single system, on the same day. If the process takes more than about 2 hours, *recheck* the signal generator against the transmitter to be sure it has not drifted off frequency.

Now, with an accurate source of rf signal, you can align the receiver's rf and antenna trimmers. If you're working on a mobile unit, you don't have to be very particular about setting the *antenna* trimmer exactly. It will have to be readjusted *after* the radio is installed in the car.

You will find that very few fixed-tuned receivers have any tuning adjustment on the oscillator. Mobile radios do have a small trimmer capacitor which can move the frequency of even crystal oscillators a few cycles. However, these sets rely solely on the accuracy of the crystal, and have no frequency adjustment at all. Variable-tuned receivers have oscillator trimmers, which should be set to make the dial track over the CB band.

Crystal checking

If you have trouble with the oscillator circuit, suspect the crystal. To find out if it can oscillate, use the arrangement in Fig. 3. The crystal is simply hooked in series between a signal generator and a vtvm.

Once you're set up, tune the signal generator (set for maximum unmodulated rf output) around the rated frequency of the crystal, which will be stamped on its case. When the generator hits the crystal frequency, the meter needle will jump sharply. Tuning is awfully critical on this test, so go slow!

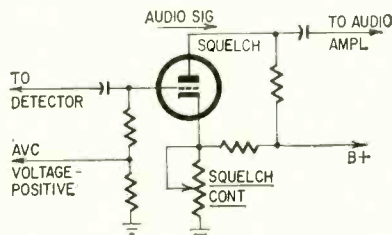

Fig. 4—Basic squelch circuit.

The average third-overtone crystal will give a reading of 2–3 volts, with a signal generator at full output. If you can't get any reading, no matter how carefully you tune, the crystal is probably cracked or dead.

By using the crystal from the transmitter, you can use this same test to set the signal generator to the exact rf carrier frequency. Tune the generator very carefully for maximum meter reading through the crystal. When you find this point, the generator is set on exactly the right rf carrier frequency. Don't use receiver crystals; they are *not* on the carrier frequency, but on the

tube. When a signal comes in, the "avc" circuit develops a positive voltage in direct proportion to the rf carrier strength. (We call this avc for the sake of analogy. Actually, it's the same thing except for polarity. A separate squelch rectifier delivers the needed positive voltage.) This bias voltage is fed to the grid, where it cancels the blocking bias applied by the cathode resistor. The tube conducts and the audio signal can flow through. When there is no rf carrier, no voltage is developed, and the squelch tube is blocked, cutting off the audio.

As the final step in aligning a mo-

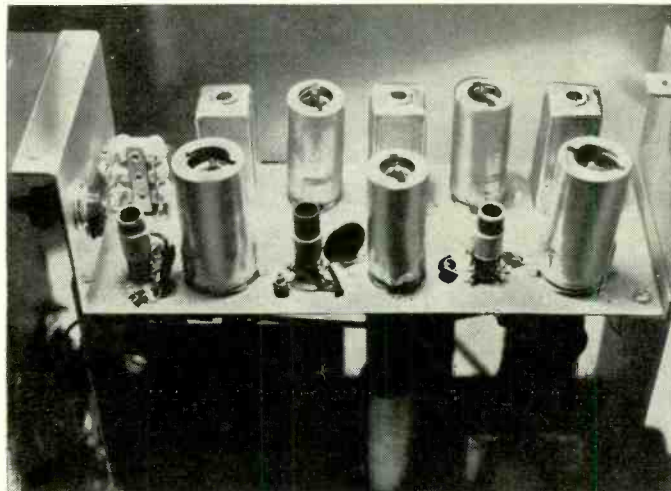

Typical superhet receiver section of CB unit.

mobile receiver, replace it in the car. After warmup, have the base station give you a short call. While listening to the call, tune the receiver's *antenna trimmer* for maximum signal.

You can trim a whip antenna, of any type, to be resonant at the transmitter frequency by tuning it to resonance when used for receiving. The Rayleigh-Carson reciprocity theorem says that an antenna has identical characteristics whether it is used for transmitting or receiving. So, if you want to replace an antenna whip or trim an existing whip to a new channel, trim it until it will resonate when receiving, and it will also be resonant for transmitting.

Check the antenna to see that it

Squelch circuits

The better receivers incorporate a squelch circuit to cut off the audio when no signal is being received. You'll find several types in use, so we won't try to go into detail on any of them. A squelch circuit will usually use one section of a tube. It is biased to cutoff by the squelch control, usually located in the cathode circuit. The tube is un-squelched or opened, by the avc bias voltage developed when a signal comes in. This allows it to conduct and pass the signal.

This is quite a simplification, of course, but it is the way that all squelch circuits work. If you find trouble, look for off-value resistors, especially in the cathode circuit. Rotate the squelch control and see if the voltage on the squelch tube varies. Check for slightly leaky coupling capacitors, which can buck out the bias voltage and cause the squelch either to refuse to open or shut off. Normal action of a squelch control will kill the audio *somewhere* near the center of the control rotation although this is not universal. In some sets, the control goes almost all the way to one end before anything happens.

Fig. 4 is the basic circuit of a squelched tube. The squelch control in the cathode places cutoff bias on the



Keying relay can sometimes be adjusted to pull in on lower voltage for positive keying at low battery voltages.



Fig. 5—Pilot light socket, pilot light and antenna connector used for dummy antenna.

is exactly a quarter wavelength for the frequency in use. In CB work, there are 23 channels. They begin at 26.965 and end at 27.255 mc.

Due to the small band of frequencies covered, there is only about a 1½-inch difference between the lowest and highest channels. A quarter-wave at 26.965 mc is 109.453 inches; at 27.255 mc it is 108.273 inches. This is a minor difference. So, we cut our antennas to approximately 27.115 mc, which is 109.25 inches. The tuning adjustments of the receiver will take care of any difference. This also holds for the transmitter. This applies only to straight quarter-wave whips, of course, not to the base-loaded or top-loaded types. These are physically shorter antennas with coils inserted in series to make them electrically one quarter wavelength long.

Rf output

It's against FCC rules for any but licensed technicians (first- or second-class Radiotelephone only) to *adjust* any radio transmitter. However, you *can* check them for rf output. You'll need to know whether a transmitter is putting out to get an idea of where the trouble lies. In a two-way radio system, if A can talk to B, but B can't talk to A, the trouble can be in *two* places: B's transmitter or A's receiver! So, you need a quick and simple test to find out whether a transmitter is really getting rf out.

Rf output indicators

What you need is a tester that will read rf and modulation. Fig. 5 shows about as simple a unit as you can get. It is a standard antenna plug with a bayonet pilot-light socket soldered to it. If the set uses a standard auto-radio type bayonet plug, use that. The pilot light is a No. 47—6.3 volts at 150 ma. It is simply connected to the antenna output and the button pushed. If the transmitter has sufficient rf output, the light will glow a bright yellow, indicating good rf output. A few tests with known good transmitters will show you what a "good" indication looks like.

Now, you can check for modula-

tion. The transmitters are supposed to be able to modulate the carrier at least 85%, which means about a 20% increase in peak rf power. To test for modulation, press the mike button and whistle sharply into the mike. The lamp should glow perceptibly brighter as long as the modulation continues.

The second method, and one which can be used without any physical contact with the transmitter at all, uses a pickup rod, diode and a meter of some kind. We use the 0–50- μ a scale of

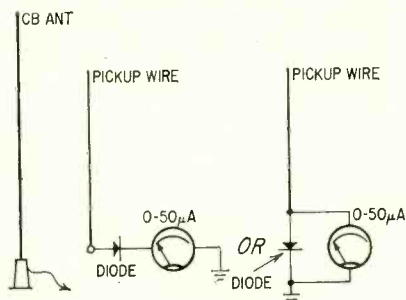

Fig. 6—Simple radiation indicator for CB transmitters. Maximum reading indicates maximum output.

our shop vom. A piece of wire or a discarded auto antenna is used to pick up rf from the CB antenna. It is connected through a diode to the vom. (The diode may be connected in series with the pickup wire or simply shunted across the meter terminals.) It rectifies the rf signal and turns it into a minute direct current (Fig. 6).

This type indicator reads nothing but radiated rf, making it about as efficient as you'd want. Maximum reading on the meter means maximum radiation from the antenna.

If the reading is not high enough, use a longer pickup wire or move closer to the transmitter antenna. However, don't get too close. If you place the pickup wire within a quarter wavelength of the antenna, you will distort the field pattern and actually reduce the total radiation. Increase the pickup rod length, or use a more sensitive meter. For maximum sensitivity, make up a tuned circuit which resonates within the 27-mc band, and connect the diode in



750-ma top-hat type silicon rectifier used to replace rectifier for keying relay voltage.

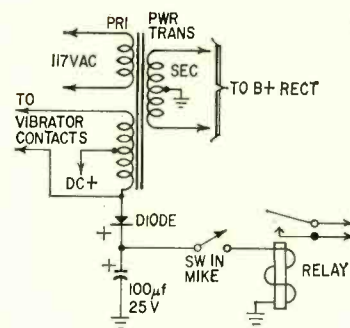

Fig. 7—Partial circuit of power transformer, rectifier and relay circuit as used in one popular CB set.

series with it. If you whistle into the mike while this test is being made, you'll see the increase in power caused by the modulation. If there is *no* increase in the meter reading with modulation, check the speech amplifier tubes, which are usually the audio output tubes in the receiver. The microphone itself may also be defective.

Keying

Some of the smaller sets use a simple selector switch to change from receive to transmit. If the equipment is mobile, it is usually controlled by a keying relay, which acts as a remote switch. This relay in turn is controlled by the pushbutton switch on the microphone.

You may find some peculiar circuits in some sets, on this keying relay. This is especially true in those designed for both 117-volt ac or 12-volt battery operation. In the ac position, the relay is energized by 12 volts dc developed, through a silicon rectifier, from the power transformer (Fig. 7). If the diode shorts, as can happen if the output is accidentally grounded, replace it with a 750-ma TV rectifier.

Some trouble has been found while working these sets on batteries. When battery voltage drops to about 10, the radio will still work but the relay won't close. To cure this, replace the relay with one that will close with 10 volts through its coil. Or you may be able to adjust the relay so it will operate at a lower voltage.

So there you are. You *can* do a lot of things with a CB set, even if you're not a licensed technician. Of course, if you take my advice, you'll get a second-class Radiotelephone license, which isn't too difficult with a little study. You can get all the dope from the Superintendent of Documents, Washington 25, D.C., in the Study Guide. In the meantime you can pick up a lot of extra business by getting into the CB repair end of our industry. There are thousands of these units running around now, and more being licensed every day. END

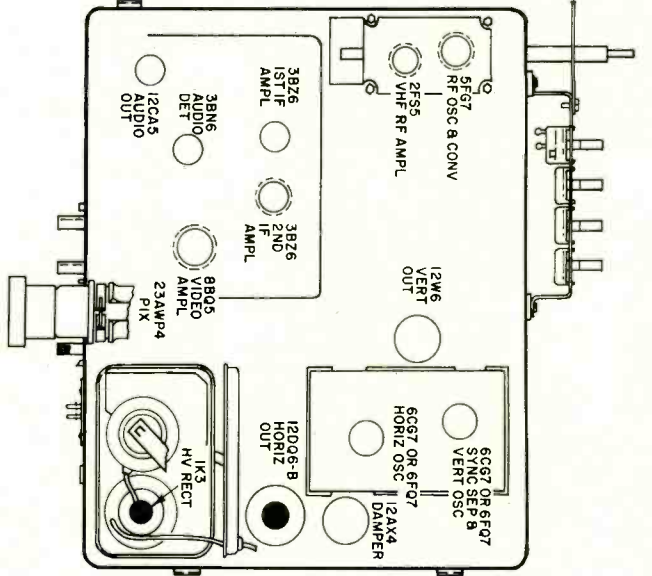

MODELS WG-3113A, 3123A, 3143A, 3153A, 3213A, 3273A, 3413A, 3423A, 3443A, 3453A, 4113A, 4123A, 4143A, 4153A, 4213A, 4273A, 4413A, 4423A, 443A, 4453A

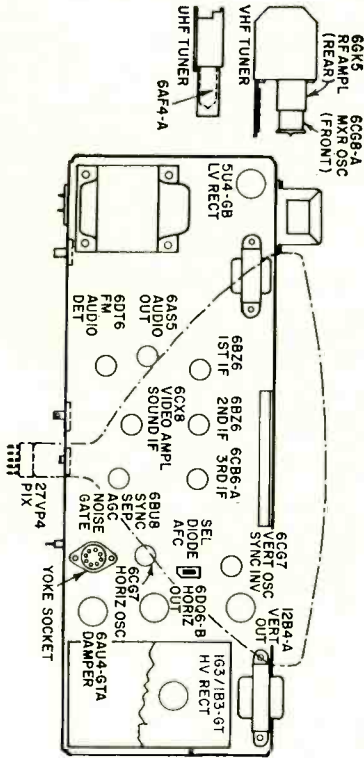

MODELS GTC-5290-A, 5390-A, 5291-A, 5391-A, 5292-A, 5392-A

MODELS GTC-5250-B, 5350-B, 5256-B, 5356-B, 5260-B, 5360-B

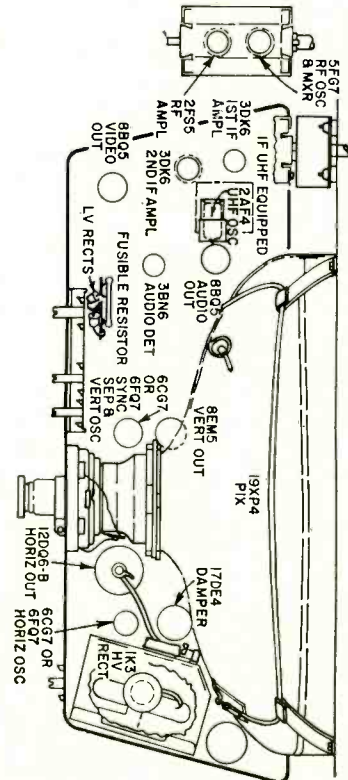

MODELS WG-3613A, 4613A, 3913A, 4913A, 3933A, 4933A, 3943A, 4943A

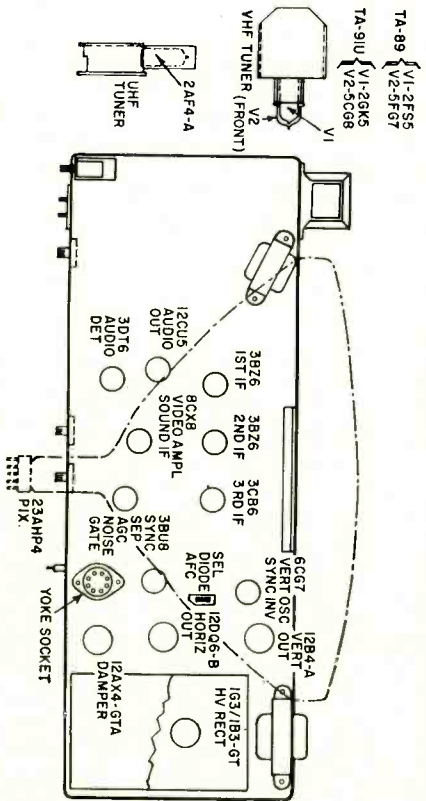

this lab's whole job is **Service Research**

TO THE AVERAGE TECHNICIAN, "LABORATORY" means a research institution. Secondly, it might be a design lab. The idea of a laboratory for TV and electronics servicing might come as a new one to many. Just what does a service laboratory do?

The chief function of the one shown in part on our cover (the RCA Service Co. lab at Cherry Hill, N. J.) is to investigate service problems and their causes in RCA TV receivers. Any new or unexplained problem in a set, particularly one which appears to be cropping up in a large number of receivers, which centers around a given component or portion of a set or—as sometimes happens—troubles isolated in a given geographical area, become immediate problems of the laboratory.

Suggestions are worked out for servicing methods or production and design changes. Service notes are also worked out and sent out to the field, as are instructions which sometimes result from production changes. (A change in the tuner, for example, may make it desirable to change the values of components in other parts of the set.) The service company also prepares all the manuals for RCA receivers.

One of the most interesting sights

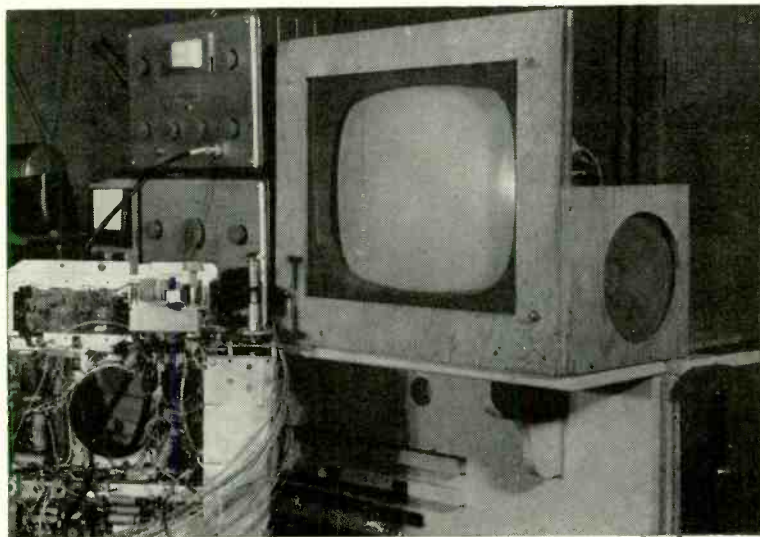

One of the jigs used in checking TV receivers.

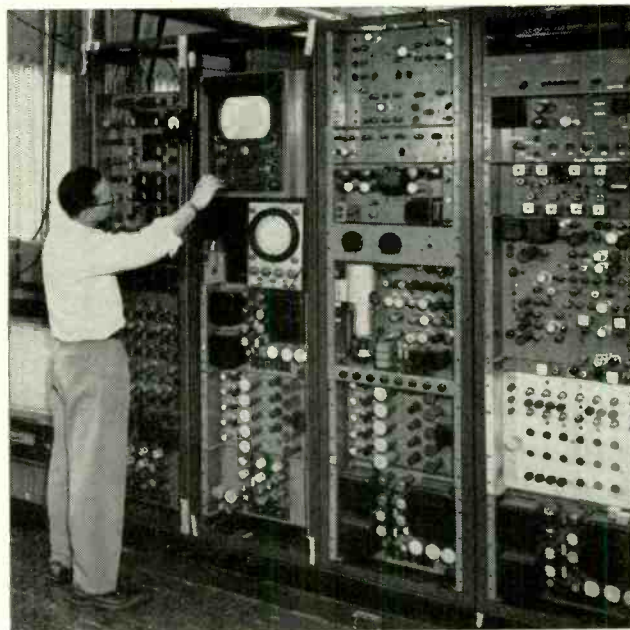

This is the signal generator used to provide all signals needed for black-and-white and color TV servicing at the Lab.

in the lab was a number of picture tubes rigged up in plain frames with yokes and associated components. There were enough of these jigs so that any model brought in could find a tube, yoke, focus and other components matched to it. (These jigs are used as time and effort-savers in all branches of the RCA Service Co. Sets can be serviced without bringing the tube to the shop, even though they may be older and less common models.)

Designs test gear, too

The service company is proud of its work in pioneering test equipment. Actually a very old organization, with its roots back in the '20's or earlier, the greater part of its business is commercial and government work. Servicing motion-picture equipment, computers,

broadcast transmitters, marine communications equipment and missile launching, guiding and tracking systems, constitute its main activities. Television, and later color television, was what drew the service company into the consumer products field. No test gear was available for much of the equipment on which the service engineers had to work.

For example, when the first all-electronic pre-war TV's were tested, the lab was asked to send six of its best engineers to install and maintain receivers. Since there was no portable test equipment worth speaking of at the time, the engineers had to develop their own, some of which became the standard dot and color bar generators now sold under the RCA trademark.

This work is still going on, and service engineers in the lab were checking TV remote controls with a piece of test equipment that bore a service company model number, and which had not (at least as yet) been put on the commercial market.

The laboratory also points out that many of its discoveries are now standard throughout the service industry, though they may not be embodied in the form of test instruments. For example, the cathode-emission rise-time method of predicting the life of a kinescope was developed by an engineer in the service company's quality laboratory, during the period when it was handling quality control for the manufacturing division of RCA. John Meagher's dynamic demonstrator, the first of a large group of electronic trainers now used, was constructed while he was an engineer for RCA Service Co.

END

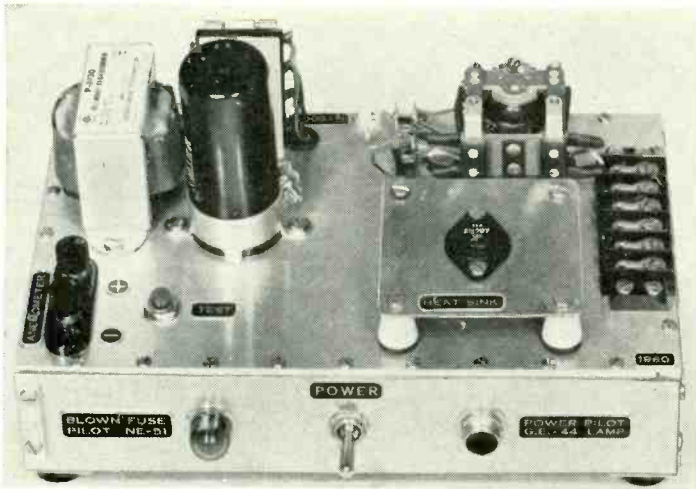

Top chassis view of the transistorized contact load multiplier.

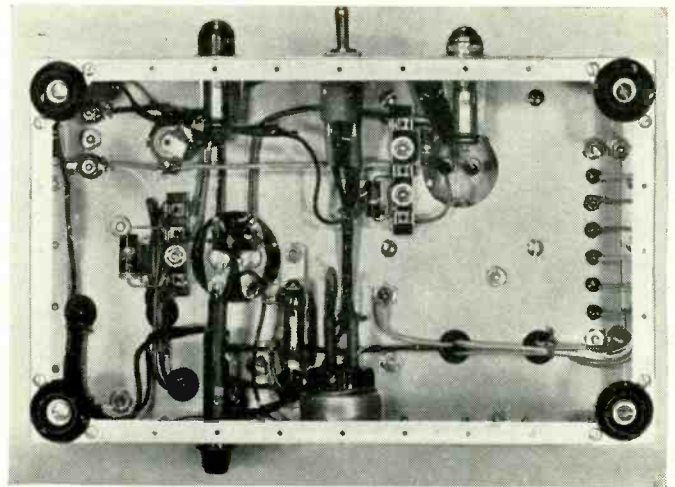

Underchassis view shows how terminal strips were used for mounting components.

contact load multipliers

Use low-power contacts to handle high-power loads

By RONALD L. IVES

AT MANY INDUSTRIAL INSTALLATIONS, as well as most research and development establishments, small contacting instruments such as thermostats, flowmeters, anemometers, pressure switches and limit indicators need an inordinate amount of servicing, largely because of contact troubles.

These instruments were originally designed to operate low to medium-current lamp and indicator loads, which are substantially resistive. Many are now controlling relays, recorders, electromechanical counters and positioning motors, often in addition to multiple lamp loads. This "adding on" leads to contact overloading, with sticking contacts dominant if the loads are resistive, and to "cone and crater" or "smallpox" contact erosion if they are inductive.

More than three decades ago, heavy loads were controlled by small contacting instruments with an intermediate medium-sensitivity relay. Coil flybacks were minimized by capacitive, capacitive-resistive or unilaterally conductive "spark absorbers". More recently, vacuum-tube switching has been widely used, and will continue to be at many installations where filament current needs, heat and sensitivity of vacuum tubes to shock and vibration are not important.

Early in 1954, when the first power transistors were made available for experimental use, a number of circuits were developed for controlling relative-

ly large power with small contacts, such as those on mercury thermostats. At that time, transistor prices were high (\$90.00 each), uniformity was nonexistent and transistors were extremely sensitive to temperature and humidity changes. These factors limited the usefulness of transistors in any ordinary control work, despite the excellent performance of some of the circuits.

A transistor circuit

Today medium-power transistors with uniform characteristics are available over the counter at less than \$2.50 each. Improvements in packaging and circuitry have made them insensitive to ordinary changes in temperature and humidity. Such transistors are used in many load controls.

The circuit of a transistorized working contact load multiplier is shown in Fig. 1. It can be used with a wide variety of transistors, loads and power

supplies. With the values shown, the control will operate directly any resistive or inductive device requiring up to 5 watts at 6 volts dc, while imposing a load of less than 100 mw (about 8 ma at 12 volts) at the instrument contacts. If the controlled device is a small industrial relay (as shown), its contacts can control loads up to 1 kw. At somewhat higher cost, the load can control a high-power transistor (to 20 or more amperes at 40 or more volts), which will directly actuate a very heavy load.

The contact load multiplier shown uses a 2N307 transistor. When its base is at approximately the same voltage as the emitter, collector-emitter conduction is minimum. If, however, the base is at approximately the same voltage as the collector, collector-emitter conduction is maximum.

As applied in Fig. 1, transistor base bias, when the instruments are open, is supplied through voltage divider R1, R2. This holds the transistor base about 1.5 volts negative with respect to the emitter, and current through the load is about 14 ma, far too little to energize the relay.

When the instrument contacts are closed, the transistor base is connected to the collector load supply line, the base is negative with respect to the emitter by the full supply voltage, and the relay coil in the collector circuit carries about 350 ma, more than enough to energize the relay.

Providing base bias through a voltage divider makes the control circuit

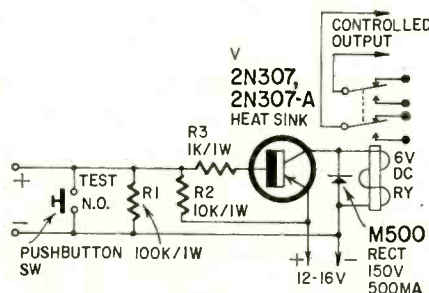

Fig. 1—Circuit of typical transistorized contact load multiplier.

substantially immune to temperature changes within wide limits. Several simpler circuits, with a series leak, can be used, at a saving of about 20 cents. They can be made to work with a specific transistor within a narrow range of temperatures only, but not with every transistor of this type nor at all temperatures within the operating range.

Shunted across the relay coil (Fig. 1), is a reversed diode. It absorbs flyback pulses from the coil. These have an amplitude many times greater than the supply voltage and a reversed polarity. If consistent performance and long equipment life are desired, this rectifier is essential, as flyback pulses have a devastating effect on most transistors.

A working model of a contact load multiplier, made for use with contacting anemometers and equipped with its own power supply, is shown in the photos. Parts are arranged for convenience during construction and operation. As no high voltages or frequencies are involved, parts placement and lead dress are not critical. In the control portion, however, there is one very critical item—the transistor heat sink. Minimum safe dimensions are 3 x 3 x 1/16-inch copper, or 5 x 5 x 1/16-inch aluminum. It must be electrically insulated from the chassis in this circuit and should be mounted so air circulation around it is not impeded. If the heat sink is omitted, the life of the transistor will be short, and circuit performance may become erratic after only a few hundred cycles of operation. Adequate heat sinks are much cheaper than replacement power transistors.

The ac input to the power supply is mounted on the rear chassis skirt. The power rectifier—a bridge of four 500-ma silicon diodes—is also in the rear. They are mounted in a four-gang clip on a vertical bracket for easy access and cooling.

Resistors and most connections are under the chassis. The resistors are mounted on terminal strips to provide firm support and easy cooling. Wiring can be done with any good grade of hookup wire, and careful workmanship here will preclude a lot of shutdowns to hunt for trouble later.

Whatever parts arrangement is used, never box in the rectifiers or the transistor heat sink, and allow for easy access to the relay contacts (if a relay load is used), to permit inspection and cleaning.

Power requirements of this contact load multiplier depend in part upon the load. For the circuit in Fig. 1, 10 volts is the minimum for dependable operation and maximum voltage tolerated by the transistor is 25. Slow voltage shifts between these limits will have no important effect on operation and will not damage components.

If batteries are used alone, 12 volts

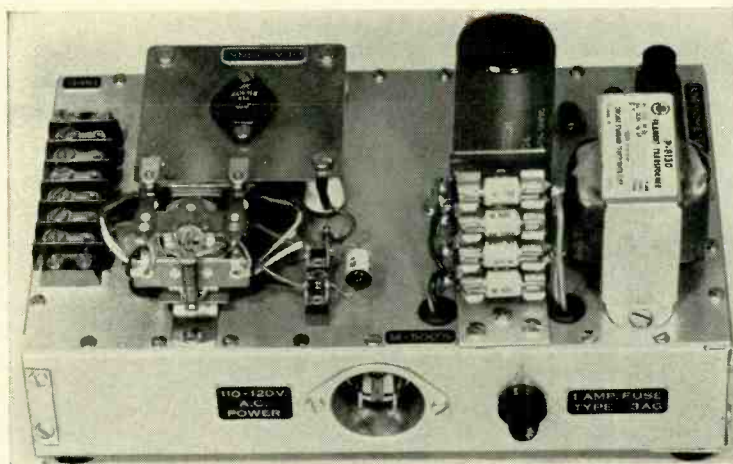

Rectifier bridge is mounted on rear of chassis. It and transistor must not be enclosed to allow for proper ventilation.

is recommended. When terminal voltage under load falls to 10, it's time for new batteries. Shunt the batteries with a 10,000- μ f capacitor to extend operating life. Now the throw-away point is reached when the contacts-open voltage falls to 10. The shunt capacitor is particularly useful in cold environments, where the internal resistance of dry cells increases rapidly, reducing the terminal voltage under load.

Where line power is available, a small power supply consisting of a step-down transformer (Stancor P-8130 or equivalent), rectifier and filter is recommended. The one shown in Fig. 2 is ideal for moderate power requirements. Output, with the values shown, is about 17 volts no load. Because of the capacitive filter, very short-term pulse loads of several amperes can be handled. If larger current capacity is desired, use a larger power transformer and higher power rectifiers, with adequate heat sinks.

Although designed to operate from a set of make-and-break contacts, the contact load multiplier will also respond to changes in resistance across the input terminals. With the values shown in Fig. 1, the load will operate promptly with 2,700 ohms across the input, and will drop out positively when the resistance across the input rises to 12,000 ohms.

This is within the range of dark and light resistances of a number of commercial photoconductive cells and wide differential operation from these cells is entirely practicable (do not exceed current limits of cells). Close differential

operation from photoconductive cells is not recommended.

With the circuit and constants shown, operation is satisfactory between 40°F and 160°F. Substituting a silicon transistor in the circuit (at about 20 times the cost) extends the satisfactory operating range approximately 100°F in each direction.

With the relay shown, operation at up to 22 counts a second was reached in the laboratory. The maximum speed for sustained industrial use is about 15 counts a second. For higher operating speeds, use special relays such as the Stevens-Arnold Millisec which permits speeds considerably higher than 100 counts a second with this circuit. If a 6-volt 5-watt electromechanical counter is used as the load in this circuit, 10 counts a second is reached easily.

Exposure to mixed beta-gamma radiation, at intensities up to 50,000 counts a minute, had no detectable effect on operation, and rf pickup by the device itself seems of no importance. In extreme cases, some filtering of a long input line, between contacts and control, may be needed.

Actual service life of this contact load multiplier can only be guessed at with present knowledge. Continuous operation at 10 counts per second for 10,000,000 counts produced no signs of wear or changed characteristics of any components.

This transistor contact load multiplier appears to be a satisfactory and relatively inexpensive solution to many industrial problems of instrument contact overloading. END

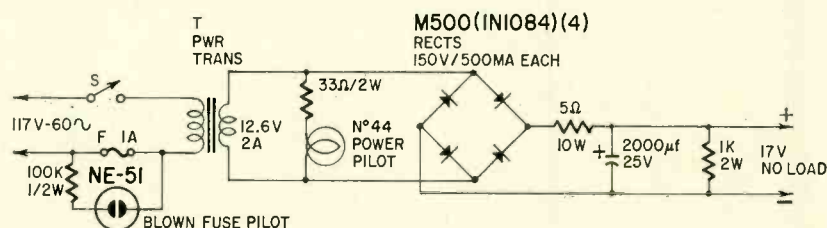

Fig. 2—Use this power supply with contact load multiplier of Fig. 1.



multipath distortion menace to FM stereo?

Six Industry Authorities
analyze the problem

MULTIPATH DISTORTION OCCURS "WHEN AN FM SIGNAL reaches the receiving antenna by two or more separate transmission paths. This is usually caused by reflection from an obstruction near either the transmitting or the receiving antenna. The signal reflector could be a large building or hill, or a moving object such as an airplane." The phenomenon is well known to television viewers as "ghosts."

Multipath distortion has been noted since the beginning of FM, but has not given most listeners much trouble. With stereo, things may be different. A much wider bandwidth is required, and multipath "ghosting" may even—under certain circumstances—put the left channel on top of the right one, confusing the stereo effect completely.

Nobody seemed to know exactly how serious multipath distortion might be, so RADIO-ELECTRONICS sent a questionnaire to a number of authorities in the field. We asked whether audible distortion, impairment of separation, or both, are the most important effects of multipath distortion: how the number of listeners affected by multipath distortion on FM stereo would compare with the number now having trouble on monophonic FM, and what is the chief hope for reducing the effects of this type of distortion. We also asked how the listener could recognize multipath, and if there were any other causes of distortion which might be confused with it. The response appears below.



L. H. Finneburgh

MULTIPATH SIGNALS CAUSE BOTH AUDIBLE distortion and impairment of separation in FM stereo reception. The audible distortion usually shows up as mushy middle tones, and raspy and harsh high tones; the impairment of separation is normally indicated by the loss of stereo effect of the subcarrier "second channel" and the presence of background noise or hiss in this "second channel". A classic example of the latter can sometimes be heard as "airplane flutter."

The degree or seriousness of multipath distortion definitely varies with locality, but our experience indicates that it is widespread and causes some distortion in a large percentage of all locations, if a top-quality directional antenna is not used.

Many other causes of poor reception and distortion, ranging from poor recordings and faulty station operation to tuners, amplifiers and speakers, of

course exist. However, these are frequently blamed when the true cause is multipath distortion. And such multipath audible distortion is found in monophonic FM, as well as stereo FM, apparently to nearly the same degree and frequency. Monophonic FM is not faced with the problem of separation of the subcarrier second channel that aggravates the stereo FM reception problem.

The FM receiver, whether monophonic or stereo and regardless of its quality, sees its receiving antenna as its source of signal, and the fidelity of its reproduction is limited to the purity and sufficiency of this signal. Receiving antenna gain is of real importance in more remote locations, and rotators may be required if directions vary greatly. High front-to-back ratio, excellence of impedance match, narrow directivity pattern front lobe and elimination of multiple side lobes are the prime factors in most locations if multipath distortions are to be eliminated, and real high fidelity realized.

We have carried on a veritable avalanche of correspondence with the field (individual consumers as well as service personnel), which verifies the

conclusions from our own engineering test work that high front-to-back ratio on the receiving antenna is probably the most single important item in the elimination of multipath distortion, which has shown up in a surprisingly large percentage of stereo FM receiving locations. A narrow directivity pattern front lobe and elimination of multiple side lobes seem to run a good second in curing these problems, along with excellent impedance-match characteristics.

Impedance-match characteristics seem to become more important as the installation becomes more remote, since installation is made on a higher mast requiring longer transmission line, thus making line reflections from impedance mismatch more important.

The fact that FM receivers have greater sensitivity than TV receivers and that FM enthusiasts are more critical and discerning seem to have combined to make the elimination of multipath reflections more critical and demanded in high-quality FM reception than in most TV reception. We also find that the FM enthusiast is more apt to study and intelligently compare FM components and antennas than the vast majority of TV viewers.



John Frank

THE MOST IMPORTANT EFFECT OF MULTIPATH distortion upon stereo reception, beyond that upon monophonic reception, is that it introduces noise and phase-shift effects in the range between 23,000 and 53,000 cycles—that part of the transmission channel carrying the stereo information.

This is heard as whistling, rushing or warbling noises in the background, accompanied by a rasping distortion, which is partly or totally eliminated when the listener's system is switched to monophonic reception.

Few localities are immune to multipath problems, although heavily populated urban areas, with concentrations of structures that reflect radio waves, undoubtedly present more of a problem than suburban or rural locations.

Distortion caused by multipath reception can easily be mistaken for poor alignment or low signal strength, and vice versa. The simplest test is to try another station in a different direction. If a rotatable antenna is being used, and it is sufficiently directional, turning it will usually establish whether the distortion is due to reflected signals.

In monophonic FM listening, the result of multipath interference is not as likely to be heard. It most often consists of ultrasonic noise, which, even if passed by the audio circuitry associated with the tuner, is not likely to be audible. It is the much greater audio bandwidth required by stereo transmission that has enlarged the problem, since the ultrasonic noise is now converted to audible frequencies by the multiplex demodulating circuitry. Moreover, the phase disturbances associated with multipath reception can severely confuse the multiplex circuit, which depends on exact phase information to sort out the left and right channels properly in a stereo program.

So, assuming that no more actual interference exists now than did before multiplexing became common, the stereo listener is more likely to have his listening disturbed. Since multipath reception causes distortion of phase, frequency and amplitude, tuners that exaggerate these effects will be especially susceptible to multipath problems; this is particularly true where limiting is poor, i.f. bandwidth narrow, or capture ratio (the rejection of co-channel interference) is inadequate.

While no simple method of designing tuners presents itself that would totally eliminate such interference, or, rather, its effects, the theory of FM reception supports the hope that this

may someday be possible. In the meantime, rotatable directional antenna systems would appear to offer the home listener the best hope of improving reception now disturbed by multipath distortion.

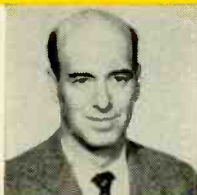

Robert E. Furst

FOR MONOPHONIC FM RECEPTION multipath distortion has never been a major problem. FM limiters have been

OUR PANEL

L. H. Finneburgh

President, Finney Co., manufacturers of FM and TV antennas.

John Frank

Director of Research, Dynaco, Inc., manufacturers of the Dynakit amplifier and Dynatuner.

Robert E. Furst

Vice president, Engineering, Harman-Kardon, Inc., manufacturers of Citation amplifiers and tuners.

F. L. Mergner

Director of Engineering, Fisher Radio Corp., pioneer manufacturer in the audio and FM field

Richard Sequerra

Assistant Chief Engineer, Marantz Co., Inc., makers of Marantz amplifier and tuner.

Daniel von Recklinghausen

Chief Research Engineer, H. H. Scott, Inc., makers of audio and FM equipment.

able to eliminate the variations in signal intensity due to cancellation and reinforcement of multipath transmission. A slight phase shift in the higher end of the audio spectrum also caused by multipath transmission is not noticeable to the ear. As a result of this, multipath reception was troublesome only in fringe areas, where transmission cancellations caused the signal at the receiving antenna to drop below the limiting capabilities of the receiver.

With FM stereo reception, the situation changed. Since the faithful reproduction of the stereo FM program requires the maintenance of very carefully controlled phase relationships of the main and subcarriers, any phase distortion caused by multipath interference will be noticeable to the listener. It manifests itself in loss of stereo separation and, in severe cases, may give rise to harmonic distortion.

During this last year, we have had the opportunity to introduce many thousands of FM tuners and receivers to the market, and have been able to study, on a nation-wide basis, the difficulties caused by FM multipath dis-

ortion. Fortunately, it appears that a very small percentage of listeners have been plagued by this difficulty. In almost all of these cases, a change in the antenna system eliminated the problem. As a remedy, we have recommended the installation of an antenna with strong directional characteristics, such as a Yagi, and a carefully installed antenna transmission line to link the receiver with the antenna without the introduction of standing waves.

Quite often the difficulties attributed to multipath interference are actually caused by improper adjustment of either the stereo broadcast equipment or the multiplex circuitry within the tuner. The audible results are similar, usually again lack of stereo separation, and audio distortion.

What can be done within the framework to the receiver design to minimize the effects of multipath interference? In my view, the most important pertinent characteristic of the receiver is the quality of the limiter circuitry and the capture ratio of the tuner. Good limiting will permit the receiver to accept the secondary transmission path only when its intensity is in the same order of magnitude as the main path. This is the case only on rare occasions.

Visual indicators have been explored which will show in some form of display the amount of multipath at the antenna. The thought here is to rotate the antenna for optimum results. All schemes proposed so far have been cumbersome and difficult to manipulate by the nontechnical public, and our field experiences have not indicated any need for this type of device.

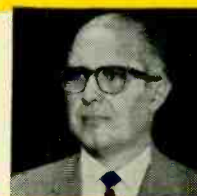

F. L. Mergner

IN FM STEREO RECEPTION, THE MOST important effect of multipath propagation is audible distortion, sometimes causing complete loss of intelligibility. Multipath distortion is accentuated during stereo broadcasts because the method used to transmit stereo information requires, not only a much wider frequency spectrum than monophonic FM, but depends to an even greater extent on amplitude and phase relationships. In addition, multipath propagation can cause an imbalance in the two sidebands produced by modulation of the 38-kc suppressed subcarrier, thus increasing distortion. Although multipath also decreases channel separation, this loss is not nearly as objectionable, because the accompanying distortion is much more disturbing.

Multipath distortion is normally

more prominent in large cities due to the greater number of reflecting surfaces, such as tall buildings, especially those with large metal surfaces. However, it can occur in outlying areas as well. Tests using monophonic transmissions show that distortion becomes more serious as the difference in path lengths and the amplitude ratio between reflected and direct signals increases.

Loose connections, especially at one of the antenna terminals, can cause mismatch between the antenna and the input circuit, a condition which will reflect and delay a portion of the signal and cause distortion which could easily be mistaken for multipath. A drifting 38-kc generator in the multiplex section, poor synchronization due to marginal gain of the 19-kc amplifying circuits, especially during weak signal periods, can also cause phase distortion in addition to loss of separation.

In some locations there can be a problem with multipath reception even on monophonic programs. Investigations have shown that for path differences less than about 1¼ miles, delayed signals of relatively large amplitude can be tolerated as long as the FM receiver maintains adequate AM suppression. As the path difference increases from 1¼ miles, the spectrum of distortion extends to higher order harmonics. Since the ear is very sensitive to such harmonics, the tolerable amplitude of the delayed (reflected) signal falls off very rapidly over the range of path difference from 5 to 12 miles.

For path differences of 18 miles and more, the harmonics spectrum extends beyond the audible range, and the distortion is heard as a hissing noise.

Tuners which maintain a minimum AM suppression of 35 to 40 db under all receiving conditions are able to reduce multipath distortion during monophonic reception to acceptable levels. Therefore, I do not feel that this problem is too serious in most areas at the present time.

I would estimate that in urban areas one out of two installations using an antenna that proved sufficient for monophonic reception could have trouble with multipath distortion during stereo transmissions.

Antennas, highly directional in the vertical as well as horizontal plane, and rotators solve most of the problems. However, good tuner design can also help. For example, having the proper match between antenna and input circuit of the FM tuner will eliminate the possibility of reflections in the lead-in. Well designed tuners with a good capture ratio (low numerical figure in db), as well as a high order of AM suppression, will generally provide much more satisfactory monophonic and stereophonic reception than others under conditions of multipath propagation.



Richard Sequerra

MULTIPATH DISTORTION OF FM STEREO reception may cause more or less severe high-frequency distortion, inability to recover the 19-kc pilot, phase shift of the upper sideband of L — R signal, reversal of the left and right, and a further decrease in the signal-to-noise ratio. How can the listener recognize it? The only practicable solution we know is our oscilloscope tuning indicator, which presents dynamically the instantaneous deviation plotted against the produced AM components of a multipath signal passing through a nonphase-linear network.

Multipath distortion quite obviously affects FM monaural reception. This can be heard as high-frequency distortion. For a long while, all of us have been guilty of blaming radio stations for the poor quality transmissions, especially at the high frequencies.

As we increase the bandwidth of the transmitted signal for stereo reception, the problems created by multipath distortion rise at an astronomical rate. We feel that most listeners are likely to have multipath distortion of FM stereo.

Frequently, antennas and rotators with the proper lead-in wire such as a 300-ohm balanced shielded cable can make significant improvements in many locations. However, there must be some tuning device which will display the amount of multipath reduction when the antenna is turned. The receiver that has the most phase-linear response will be least subject to multipath distortion in all cases.

Unfortunately, little serious theoretical work has been done on multipath phenomena. We are all quite ignorant of the specific quantities and qualities. This is what we at the Marantz Co. think:

The long time delay between wanted and unwanted signals is the characteristic that produces the most severe multipath distortion, unlike the short-path delay that produces the most significant ghosts on television.

If the field strength of the unwanted signal or signals can be made sufficiently low relative to the wanted signal, we will have very low distortion. With the use of the antenna, rotator, proper balanced lead-in and a linear-

phase i.f. system, we can achieve in almost all cases a very significant improvement in the sound and insure the maximum of stereo separation for a given receiving situation.



Daniel von Recklinghausen

MULTIPATH DISTORTION IS THE RESULT of multipath interference. The transmitted signal reaches the antenna simultaneously over direct and reflected paths. These signals add in phase and in amplitude, and cause undesired phase and amplitude modulation.

The most obvious result of multipath interference is audible distortion that is more noticeable with the tuner in the stereo than in the monophonic mode. The amount of phase modulation is approximately proportional to modulating frequencies, and therefore the higher frequencies show more distortion than the lower ones. With an ideal tuner, only phase modulation will be noticed. The tuner's amount of amplitude rejection is a measure of its performance—at least 40 db is required for good performance.

If the tuner has poor AM rejection, distortion will be greater. The more multipath interference is present the more stringent is the job the tuner has to perform. A directional antenna will always reduce multipath distortion, but this may be difficult to do in cities where landlords may not permit outdoor antennas, or in areas where multiple reflections are too numerous to be eliminated by antenna directivity.

Distortion in the tuner is frequently blamed on multipath interference, but often may actually be a distorted signal produced by the station. The FCC permits distortion values between 2.5 and 3.5%, not including the amount of distortion in the original recorded material. Therefore any added distortion due to multipath may be unnoticeable because it is relatively small. For best results, a tuner engineered for multiplex operation should always be used. Some earlier tuners were not engineered for that, and show a fair amount of high-frequency distortion.

Separation may be affected to some slight degree by multipath distortion but generally the amount of distortion is considerably higher in the audible degradation of separation.

Summary

It would appear, then, that while agreement on many of the phases of multipath distortion is not complete, there is a general tendency to agree that the remedy lies in an excellent directional and well matched antenna, and that there may be possibilities of further improving the situation by attention to a number of other factors. Especially, excellence in tuner design may have an important effect. END

BUILD

Two transistors and thermistor probes give you an accurate electronic thermometer

the TEMP-ALL

Here is an electronic thermometer equivalent to a pair of high-quality glass thermometers without any of their disadvantages. The unit is compact and rugged enough to withstand very rough handling. Its indicating meter can be located remotely in a position where it can be viewed in comfort.

Temp-All can be used to check the operating temperatures of components in tube and transistor circuits. It will measure the temperature inside an enclosure containing the circuits, the case temperature of the transistors or tubes, the case temperatures of the various components—transformers, power re-

sistors, etc. It will also measure inside-outside air temperature for checking the effectiveness of an air-conditioner, for example. Other possibilities are limited only by the inventiveness of the builder.

Six selected ranges cover -15 to $+125^{\circ}\text{C}$, or $+5$ to $+257^{\circ}\text{F}$. A panel switch selects either of two probes which can be mounted in two locations. The meter indicates the temperature at the two locations, so the difference between them can be readily figured. Only one probe is used for spot temperature measurements at one location. The instrument is battery-operated, completely portable and can be held in one hand while the other hand directs the probe.

How it works

The temperature-sensing probes are thermistors, semiconductors whose resistance varies with temperature. The simplified schematic of the Temp-All (Fig. 1) shows the thermistor mounted in one leg of a bridge circuit fed by a constant-voltage battery. As the thermistor's resistance varies with temperature the currents in the bridge arms vary accordingly. The voltage difference between points A and B changes in direct proportion to the current flow. This voltage change is amplified by a transistor dc bridge amplifier to drive an indicating meter.

Range resistor values in Fig. 2 are selected to allow the bridge to balance at the lower end of each range. When the temperature increases, the thermistor's resistance decreases and the amplified voltage change causes the meter to deflect upward.

The bridge voltage is fed to the transistor bases through isolating resistors R15 and R16. This transistor bridge amplifier is similar to those found in vtm circuits and amplifies very small voltage differences. The voltages fed to the bases are opposite in polarity, causing one transistor's collector current to decrease and the other to increase. The microammeter is connected across collector load resistors R21 and R23 in conjunction with R22, the ZERO ADJUST potentiometer.

S4, when pressed, shorts the bridge and places an equal potential at each transistor base. Then R22 is adjusted to allow equal current flow through both transistors, so the meter reads zero. When S4 is released, the circuit is balanced and ready to accept the bridge voltage. Resistors R17 through R20 are the transistor base-biasing networks, and R9 through R14 form meter shunts for each range.

The amplifier is powered by a 6.5-volt mercury battery with a nominal drain of 1 milliamper.

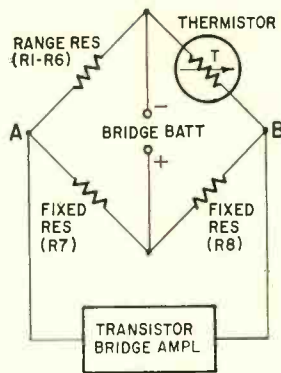

Fig. 1—Simplified circuit of the Temp-All.

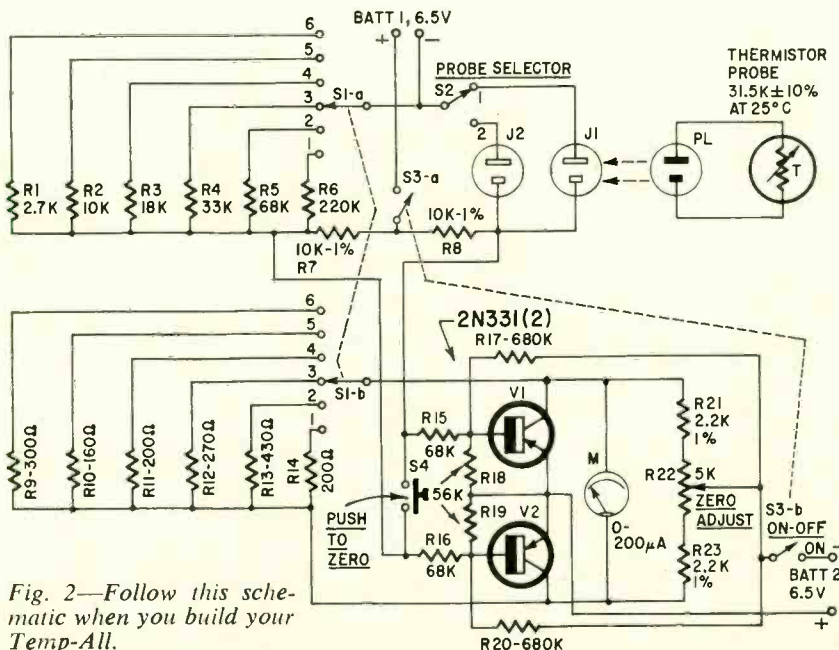
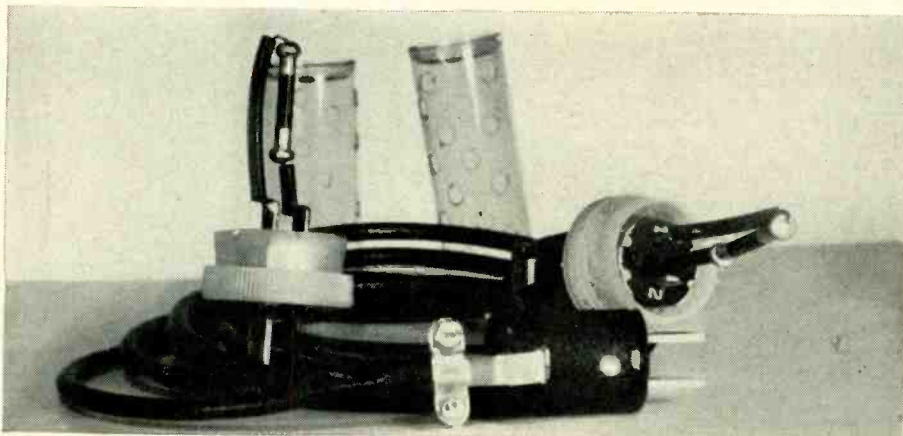

Fig. 2—Follow this schematic when you build your Temp-All.

- R1—2,700 ohms
- R2—10,000 ohms
- R3—18,000 ohms
- R4—33,000 ohms
- R5, R15, R16—68,000 ohms
- R6—220,000 ohms
- R7, R8—10,000 ohms, 1%
- R9—300 ohms
- R10—160 ohms
- R11, R14—200 ohms
- R12—270 ohms
- R13—430 ohms
- R17, R20—680,000 ohms
- R18, R19—56,000 ohms
- R21, R23—2,200 ohms, 1%
- R22—pot, 5,000 ohms, wirewound, miniature
- All fixed resistors 1/2-watt 5% unless noted
- BATT 1, BATT 2—6.5 volts, mercury (Mallory TR-165R or equivalent)
- J1, J2—2-terminal jacks
- M—200 microamperes (Weston model 1301 or equivalent)
- PL—2-terminal plugs to match J1, J2 (one for each probe you plan to use)
- S1—6-position 2-pole miniature rotary
- S2—spdt toggle or rotary
- S3—dpst toggle
- S4—spst, spring-loaded momentary-contact pushbutton
- Thermistors, rod-type, 31,500 ohms $\pm 10\%$ at 25°C (Fenwal Electronics type RA43L1) one for each probe you build
- V1, V2—2N331
- Transistor sockets (2)
- Plastic pill vials (one for each probe you build)
- Case—5 x 4 x 3 inches
- Miscellaneous hardware



The temperature-sensing probes. Their cases have been removed to reveal the thermistor element.

Construction and checkout

Try to use transistors whose dc current gains are very nearly equal. Close matching is a must—use a good transistor checker. This is important. It will be impossible to zero the Temp-All with very unbalanced transistors. All other components are standard and easily obtainable, and layout and wiring placement are definitely not critical.

The amplifier and bridge circuit including all resistors and transistor sockets is mounted on a perforated board, which in turn is mounted on the meter's terminal posts. To simplify construction, mount all resistors and the two sockets to the board and complete as much wiring as possible. Then, install the switches, jacks, meter and battery mount, and connect these parts. Finally, fasten the board to the meter terminals and complete the few remaining connections between board and switches.

The thermistor probes consist of a thermistor mounted by its leads to a two-prong mating plug installed in the cap of an ordinary plastic pill vial. The body of the vial has holes drilled into its sides to allow the thermistors to sense the temperature of the surrounding air. Make several long shielded twisted-pair cables with mating connectors to connect the probes to the main unit when it is desired to place the probes at a remote location.

When construction is complete, carefully observe the correct polarity of BATT 2 and insert it into its mount. Do not insert BATT 1 at this time. Disconnect the negative battery lead and temporarily insert a milliammeter in series with the lead and circuit. Rotate S3 to ON and observe the milliammeter reading. If it is appreciably higher than 1 ma, disconnect the power immediately and check circuit wiring, and transistors if necessary, for a defective connection or component.

If the milliammeter reading is normal, switch power off and reconnect the battery lead. Throw S3 back to ON, press

the PUSH-TO-ZERO switch and rotate the ZERO ADJUST control in both directions. This will swing the needle of the meter above and below the zero mark on the meter. Then, switch power off, observe the proper polarity of BATT 1 and place it in its mount.

Plug a thermistor probe into J1, rotate the PROBE SELECTOR switch to position 1 and turn the RANGE control (S1) to position 2. Throw S3 to ON, press S4 and zero the meter, then release S4. If the air around the workbench is about normal room temperature (70°F), the meter needle will be indicating between half and full scale. You can now proceed with the calibration.

Calibration is easy

There are two ways to calibrate the Temp-All. The first is fairly simple and requires only the use of a precision resistor decade box. The thermistor manufacturer plots an average curve of resistance vs temperature for the thermistor used in this test unit. If a number of fixed resistors are substituted for the thermistor in the bridge arm, the meter deflects to a reading which represents the temperature indicated by the manufacturer's curve. Simply substitute the decade box set at the resistances shown in the table, note the meter reading and mark it as the indicated temperature. When this reading occurs again with the thermistor probe plugged into place, the temperature of the thermistor will be the same as the resistor-calibrated temperature reading.

The ranges overlap, allowing a particular temperature point at the high end of one range to appear again at the low end of the next range. The thermistor manufacturer specifies a maximum of 10% tolerance between individual thermistor units, but I have yet to find any which has exceeded 5%. It is reasonable, then, to expect about 5% to 10% accuracy in temperature readings using this method of calibration.

Accuracy on the order of 2% can be obtained by hand-calibrating the thermistor probes. This requires the use

Calibration Chart

RANGE	CALIBRATING RESISTANCE (Kilohms)	DEGREES C
1	230	-15
	195.1	-12
	175.2	-10
	150.1	-7
	136.8	-5
	119.7	-3
	107	-1
	100	0
	97.9	1
	89	3
79.1	5	
2	75.2	7
	62.7	10
	56.2	12
	49.1	15
	42.3	18
	39.5	20
	34.9	23
31.5	25	
3	28.8	27
	26.1	30
	22.5	33
	21.1	35
19.4	37	
4	16.75	40
	15	43
	13.9	45
	12.8	47
	11.3	50
	10.1	53
9.6	55	
5	8.8	57
	7.819	60
	6.95	63
	6.5	65
	6.1	67
	5.5	70
	4.85	73
	4.6	75
	4.25	77
	3.950	80
3.5	83	
3.35	85	
3.3	87	
2.875	90	
6	2.65	93
	2.48	95
	2.37	97
	2.17	100
	1.97	103
	1.83	105
	1.73	107
	1.58	110
	1.44	113
	1.35	115
	1.25	117
	1.14	120
	1.02	123
0.97	125	



Front-panel closeup of the Temp-All.

of good glass thermometers to cover the entire range. The probe and thermometer are heated and cooled together, and the temperature readings of the glass type are noted vs the meter reading. Although this is a long process, the end result is an accurate scale comparable to the accuracy of the glass thermometer. I submerged a glass type and thermistor probe into a small can of light machine oil which was heated on a stove and cooled in a freezer to obtain the temperature ranges.

How to use it

Air temperature measurements at one or two locations are simple. One probe is usually plugged into J1 on top of the main unit in one location and the other probe is located at some remote spot. Switching the PROBE SELECTOR back and forth gives the readings at both locations. If the RANGE switch is on an incorrect range, the meter will indicate below zero or above 200. Merely rotate the range switch until the reading is on scale, press the PUSH-TO-ZERO switch and zero the meter, release and note the reading. Look it up on the calibration chart and obtain the temperature reading.

A measurement at one location is obtained with one probe at the end of a short cable held in the area to be checked. Case temperatures are obtained by removing the plastic vial body and touching the tip of the thermistor to the component. The limiting maximum temperature for the probe's soldered leads is 125°C. If the components to be measured are very hot, locate the probe nearby, but not touching the com-

Parts layout inside the case.

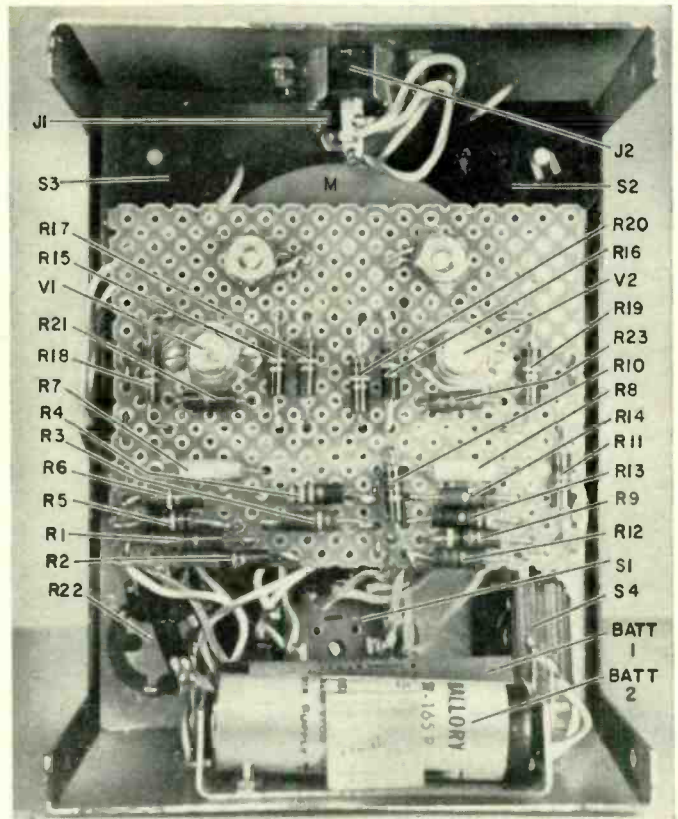

ponent, to determine whether the nearby temperature is near the limit. If not, touch the probe to the part, but keep observing the meter! In all measurements, allow the probes to remain in place for a minute or two to obtain an accurate reading.

My Temp-All has been used constantly for electronic and general scientific measurements of heat and cold. It

is constantly used to check whether transistor circuitry is operating in a safe temperature environment. Its cost is nominal, and the unit has paid for itself by saving a number of power transistors which were mounted on inadequate heat sinks and several electrolytics mounted too close to a power transformer. You'll soon wonder how you got along without the Temp-All. END

Efficient Measurement

A dealer receives five boxes full of carbon resistors. Each resistor is marked with three red bands and one gold. The factory sends notice that one of the boxes should have had orange rather than red for the second band. The dealer tells his assistant to locate the defective box with four ohmmeter measurements. The assistant does it with only one measurement. How?—*Albert S. Lombard*

Open Circuit

Here we have a two-terminal black box which apparently has some kind of internal power supply. Shorting the terminals gives us a circuit carrying 5 amperes (Fig. 1). The researcher picks up a convenient resistor and places it across the terminals (Fig. 2). Now 3 amperes flow, and the voltage drop

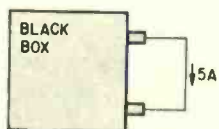

Fig. 1

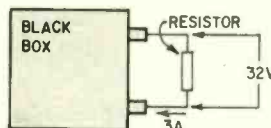
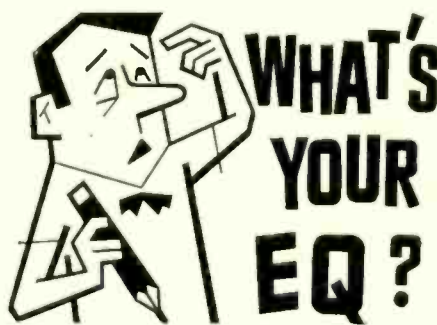

Fig. 2

across the resistor is 32. What will the terminal voltage be if no current is drawn?—*Charles S. Bryant*.

Lights and Chicken Farmer

A chicken farmer has four chicken houses and his home arranged as shown. He uses one powerful lamp in

the center to illuminate the whole area so he can see to go from one house to another. When he arrives at any building, he wants to turn the lamp off. When night catches him indoors, he wants to turn the light on before going out. This can be done with only two

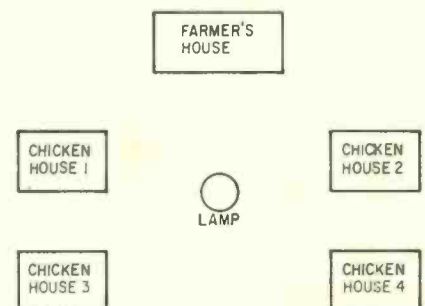

hot wires from house to house and, of course, the lamp will have to be connected. (*Hint: one lamp wire from the farmer's home, and one from one of the chicken houses.*) Use only three dpdt switches and two spst switches.—*Ray McQueen*

Answers on page 63

Electronic music is here

No longer a creature of the wild-eyed theorist or artist, it has practical applications both for the professional and amateur musician

By JAMES W. ESSEX

AS FAR BACK AS 1944, DAVID RAKSIN, HOLLYWOOD film music composer, used electronic music to get the film "Laura" off the ground. Full of melodrama, the picture somehow failed until he hit upon the idea of adding to the music, at a moment of particular emotional build-up, a weird, spine-chilling sound, like a wind mounting in loudness, wave upon wave.

To manufacture it, he chose the sound of a multitude of piano strings, which, when struck, gave off a peculiar "whine". To sustain the sound thus made, he amplified it progressively to offset the natural decay of the piano string once struck.

The initial hammer "blow" also had to be deleted. How it was done is illustrated here. Fig. 1-a shows a piano note—a highly damped oscillation. Raksin arranged that, immediately after the hammers struck, amplification of the ensuing "hum" would begin—not before. Then, as the natural wave train decayed, the amplifier would be gradually "turned up" (Fig. 1-b), compensating for the drop in volume and securing a continuous sound of uniform volume (Fig. 1-c).

Of course, there was a limit to this.

Happily, recording on film allowed the process to be duplicated endlessly by merely "photographing" the sound waves over and over again. The desired "weird" sound was then dubbed in over the music.

My own acquaintance with electronic music began almost by accident, as an amateur violist in the Stratford Civic Orchestra. I needed suitable accompaniment for practicing difficult passages at home. Such selections as Schubert's *Unfinished Symphony*, for example, with its long bass violin introduction, presented real problems. If I could simulate a bass violin with my own instrument, I could practice coming in at the difficult point where the bass violins left off and the violins commenced. Timing was important, and it would help to have that introduction played! But the bass violin cannot be effectively simulated on an ordinary violin.

I had heard something of the new art called "electronic music" at the Stratford Composers Conference. To me, it was a parade of weird noises, but they did produce some interesting effects.

I have a tape recorder and other

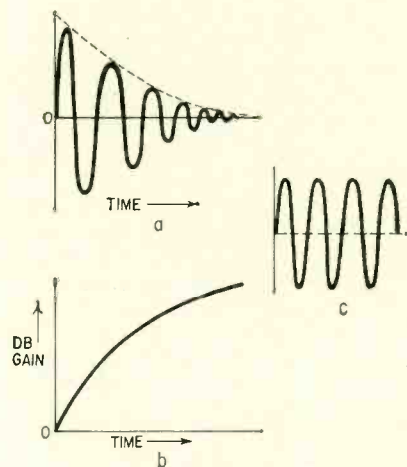

Fig. 1—How the "rising wind" effect was produced from a combination of piano notes.

top-flight equipment here at the University of Waterloo (Ontario, Canada). With the recorder, any sound phenomena can be readily investigated. In addition, the Scott noise generator and the Hewlett-Packard signal generator gave me sound sources to draw upon.

The tape recorder was the obvious answer. The one I used has two speeds—7.5 and 15 ips. If I played the violin at its lowest register but recorded at twice the playback speed, I could get a frequency division of 2. A note played at 246.94 cycles, for example, would be heard from the tape recorder at 123.47 cycles (Fig. 2).

Even so, the violin wasn't able to get low F, but it did not alter the basic idea, which was good and served me well. In playing the passage, the normal time was shortened by half. On playback (the tape was now going at 7.5 ips) the notes were held twice as long, and timing was correct.

Author using violin to produce near-sawtooth waves on tape and scope.
University of Waterloo

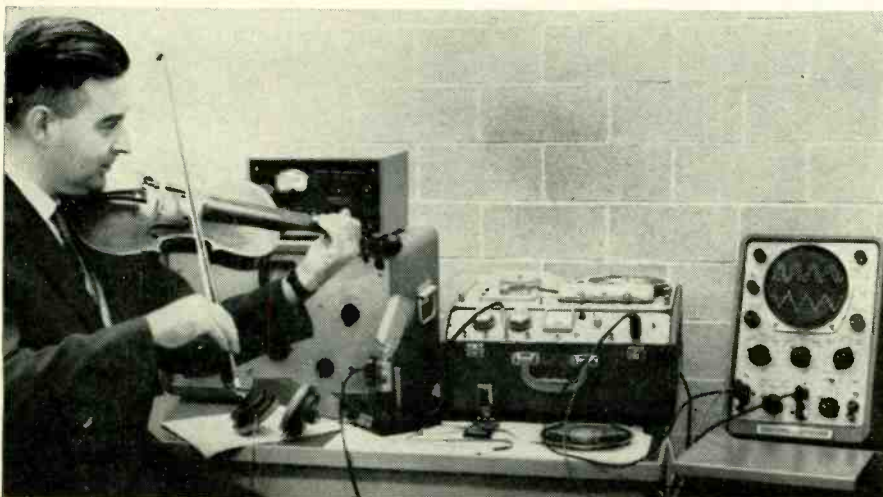

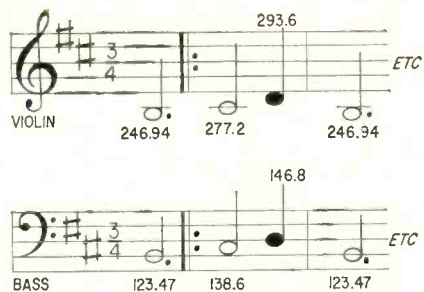

Fig. 2—How the bass violin is simulated.

From here, I went on to discover what the simple change in one parameter of a tone can do. For example, any tone, continued at constant speed with judicious use of the volume control, can be altered to resemble an entirely different instrument. A recording of a sustained violin tone can be played back with an initial "burst" of volume and thus simulate the plucked string of the Hawaiian guitar (Fig. 3)! Amplitude as well as tone can be varied to produce effects not originally there.

My 202A Function Generator has a range of 1,200 cycles down to .008 cycle. In addition, it has three kinds of outputs—sinusoidal, square and triangular. Why not, I thought, use this generator to simulate the bass violin experiment? I could then do it entirely by electronics. Its range could more than adequately cover the very lowest reaches of the bass as well as rise to 120 cycles and above. But which type of wave would give me a tone closest to the bass violin?

I knew, from RCA's Dr. H. F. Olson's studies of stringed instruments, the violin gave off waves closely resembling the sawtooth (Fig. 4). Thus, it would appear that the triangular wave, resembling more closely the sawtooth, should give the result I looked for. To "play" the signal generator, I scaled off the bass violin's notes with comparative signal generator dial settings.

The square wave is richer in harmonics than the triangular. This fact, in view of what's been said about stringed instruments, would make it seem that for a bass violin imitation,

the square wave would be it (Fig. 5)! Not so! I found the triangular output more pleasing and more realistic. And the reason, after it was all figured out, was simpler than it first appeared. The triangular wave more nearly resembles the sine wave than does the square (Fig. 6). Except for the sharp peak, it is virtually a sine wave. Yet, the sine wave—lacking harmonics or "color"—could not be passed off as anything resembling a bass violin.

Why then can the triangular? The only reason I can give is that it more closely achieved or "matched" the basic frequencies of the bass violin. Thus, at a frequency setting of 50 cycles, for example, my ear hears 50 cycles. Switched to the square wave, the tone had such a preponderance of harmonics I couldn't tell if I was hearing 50, 100 or 150 cycles. And the ear's natural lack of response at the lower frequencies, especially below 75 cycles, made me think I was hearing a fundamental of 150 cycles. This was very confusing and gave the impression I couldn't reach 50 cycles or, by corollary, I couldn't "play" the low notes of the bass.

Because it's the relative amplitude of the harmonics to the fundamental that determines the kind of instrument heard, duplicating this pattern results in a reasonable facsimile, electronically, of the instrument desired. The violin is a case in point. The stringed musical instruments emit sawtooth waves. I learned that this is due to the method in which tones are produced in the violin, for example. In crossing the strings on a bowed instrument, there's an initial pull exerted by the bow, followed by a vibration of diminishing strength.

Frequency spectrum analysis, or the study of harmonic relationships to a fundamental, tells us some interesting things about musical instruments. For example, the violin sounds different from the flute because it's far richer in harmonics! Compare Figs. 7-a and 7-b, showing response for the two instruments playing a comparative note. While the flute is practically without harmonics, the violin displays many harmonics with much strength. END

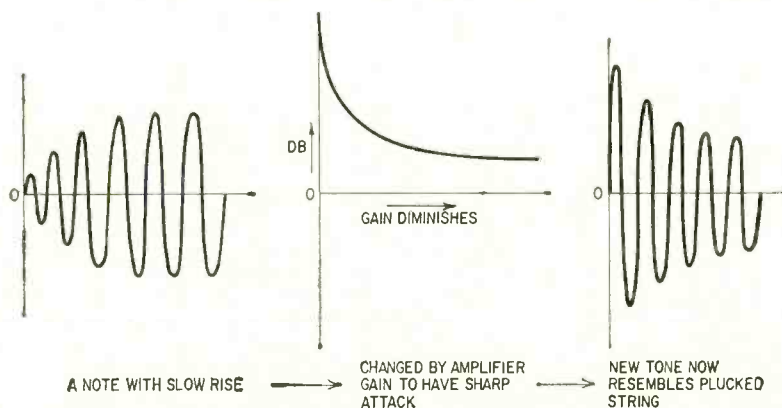

Fig. 3—A violin may sound like a guitar on tape.

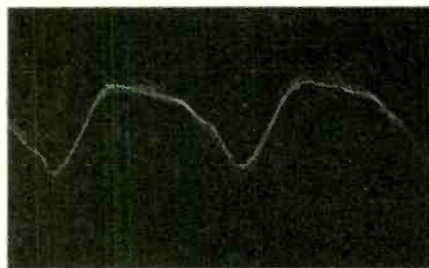

Fig. 4a—Sawtooth pattern of violin bowed carefully. b—Composite photo of violin waveforms, compared with triangular output of H-P low-frequency function generator 202A.



Fig. 5—Attempt to bow the violin with medium pressure and slow stroke to obtain a square wave. Square wave from signal generator is shown below, for comparison.

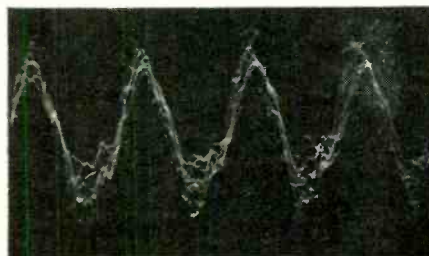

Fig. 6—Attempt to reproduce sine waves on the violin.

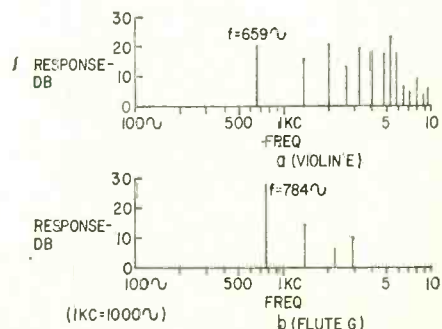

Fig. 7—Comparative response of violin and flute when playing a similar note.

unsuspected cause of TV color failure

The bad capacitor can lurk everywhere

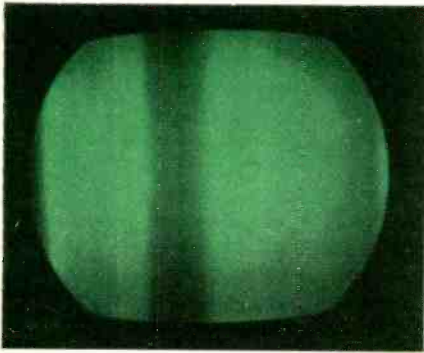

Fig. 1—Very weak color bar pattern.

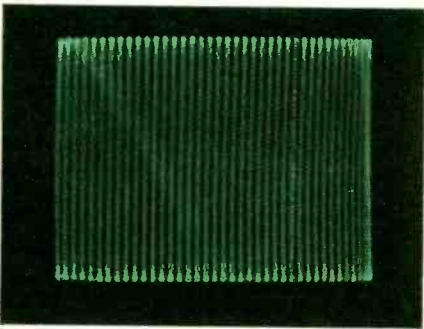

Fig. 2—Injection voltage from subcarrier oscillator. This pattern shows normal amplitude.

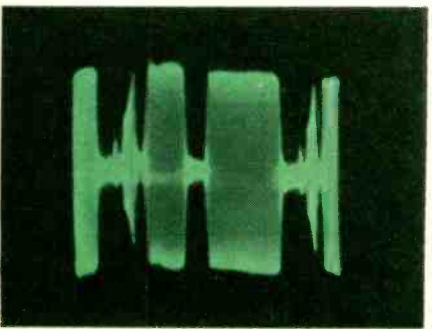
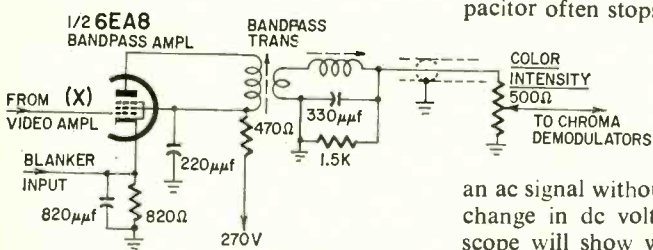

Fig. 3—Normal waveform at point X in the bandpass amplifier circuit.

A SURPRISINGLY LARGE NUMBER OF COLOR TV failures are due to capacitors. The technician expects to find these in circuits which operate at B-plus or screen-grid voltages. Leaky or shorted capacitors in cathode circuits are less common because working voltages are comparatively low. The few pulsed circuits in color receivers are another story. Capacitors in these circuits have the poorest life expectancy. This results from the strenuous "working" of the dielectric by pulse voltages. Capacitor failure in a keyed-age circuit, for example, would not be unusual. On the other hand, a capacitor failure in a tuned signal circuit with zero dc voltage is quite unexpected. A complaint of very weak color (Fig. 1) is generally pinpointed by changing tubes first, and next by measuring dc voltages and resistances in the chroma section. As a leaky or shorted capacitor usually shows up on dc voltage and resistance tests, capacitor trouble did not appear likely because all dc voltages and resistances were normal.

There was a trace of color in the pattern when the intensity control was turned all the way up. Black-and-white reception was normal. As a last resort, a wide-band scope with a low-capacitance probe was set up. An open capacitor often stops (or greatly weakens)

an ac signal without causing a significant change in dc voltages. In such cases a scope will show whether the signal can be traced to one end of a coupling capacitor, only to disappear at the other end. A scope likewise shows whether the output from the subcarrier oscillator is weak or absent.

I checked the oscillator output and found the pattern of Fig. 2, which showed normal injection levels. With the oscillator cleared, I traced the chroma signal next. A color bar generator was used to drive the receiver, instead of an antenna signal. It has the advantage of supplying a steady and standardized signal, which can be adjusted for level or various chroma components as may appear desirable.

The color bar generator was set for I and Q output since the trouble was in the chroma section. With the low-capacitance probe at the bandpass amplifier input, a normal waveform was displayed (Fig. 3). The burst signal, followed by the I and Q signals, appeared normal. The burst is somewhat distorted by the blanker characteristics, but this is of no significance. The horizontal sync pulse is absent, being rejected by the chroma-bandpass input circuit (not shown in Fig. 3). This also is normal.

However, when the probe was applied at the color intensity control, it was an entirely different story. Here, the chroma signal appeared weak and contained integrative distortion (integration of pulses, Fig. 4-a). Now the trouble was pinpointed to the bandpass output circuit. The transformer appeared OK on a continuity test, but might have had some shorted turns. This could account for the integrative distortion as well as the weak output. However, the same symptom would result from a defective 330-µF tuning capacitor. One end of the capacitor was disconnected, and an ohmmeter test made. The meter read 40 ohms!

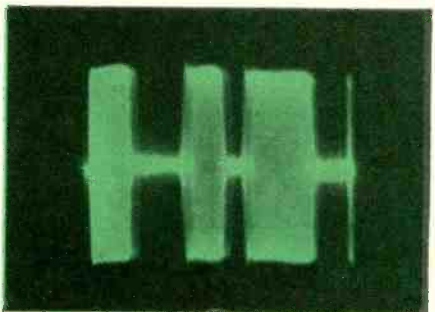
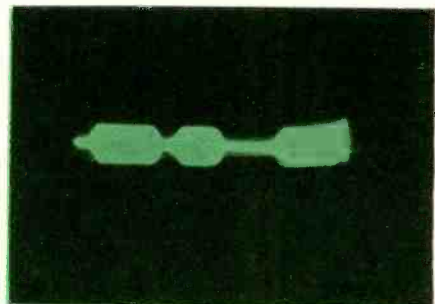

Fig. 4-a—Improper waveform (top) at the color intensity control. b—Correct waveform (bottom).

With a replacement capacitor wired in, receiver operation snapped back to normal (Fig. 4-b). This rather unusual color TV service case ended up on the profit side of the ledger thanks to prompt use of a scope when meter readings offered no clues.

Another capacitor kick

This general approach brings to mind an earlier job on a somewhat similar chassis which also had an unusual capacitor trouble. The complaint was distorted color, with noticeable absence of green hues, and the defect did not show up on dc voltage and resistance tests. There was plenty of color, such as it was. Black-and-white reception was normal. The hue control was operative, but greens were not reproduced if the red and blue bars were properly phased in.

Picture analysis accordingly threw suspicion on the G-Y section. Dc voltages and resistances were well within tolerance, and a wide-band scope was brought in to conduct a cross-examination. The input (cathode) waveform was normal, but the second test (Fig. 5) showed an abnormally large and distorted waveform at the grid bypass capacitor. The most likely cause would be an open capacitor. This was quickly confirmed by bridging the suspect (the .01- μ f unit in the grid circuit) with a replacement. The green, cyan and yellow bars reappeared.

To understand why the greens disappear from the picture when the .01-capacitor is open, note that the cathode of the G-Y amplifier is driven from the cathodes of the R-Y and B-Y amplifiers. The G-Y stage operates as a grounded-grid amplifier. Because of interelectrode capacitance between grid and cathode, the grid "follows" the cathode unless the grid is returned to ac ground. So, when the .01- μ f capacitor opens, the amplifier action substantially disappears.

The dc distribution in Fig. 5 is not entirely obvious, and may appear unusual. Although the grid is returned to the 13.7-volt cathode, it measures only 6.5 volts. The reason is based on signal-developed bias. Although there is no signal as such specified while making dc voltage measurements, the noise level is fairly high, because the G-Y amplifier is preceded by numerous stages, and the age line is not clamped. The noise voltages drive the cathode of the tube and, although the grid is grounded for ac, grid current is drawn on negative peaks of drive. A negative drive to the cathode is the same as a positive drive to the grid.

The grid would rest at 13.7 volts were it not for grid-current flow which cancels about half of the cathode bias voltage. As would be expected, if you shunt a large capacitor across the 560-

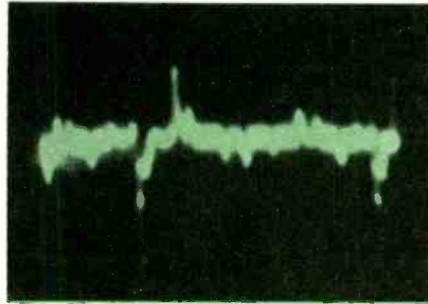
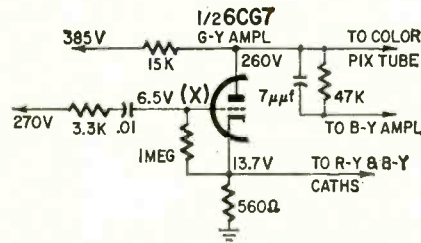

Fig. 5—Normal waveform found at point X in G-Y amplifier circuit.

ohm cathode resistor, the dc voltages at grid and cathode become the same, except for a small contact-potential shift. The ac ground return in Fig. 5 is made from grid to B-plus instead of chassis ground because the R-Y and B-Y amplifiers have their grids coupled to preceding plate circuits energized from the same B-plus line. The scope shows a small ripple on the supply line, which varies with the changing chroma signal. Thus, this method of returning the G-Y grid to ground prevents the chroma amplifiers from seesawing the B-plus ripple.

Noise on video waveforms

The noise voltages which produce the perhaps unexpected dc distribution in the G-Y amplifier also appear superimposed on video waveforms whenever i.f. bias is low. Fig. 6 shows noise on a video amplifier signal. To avoid noise disturbance in waveform checks, set the color bar generator output for

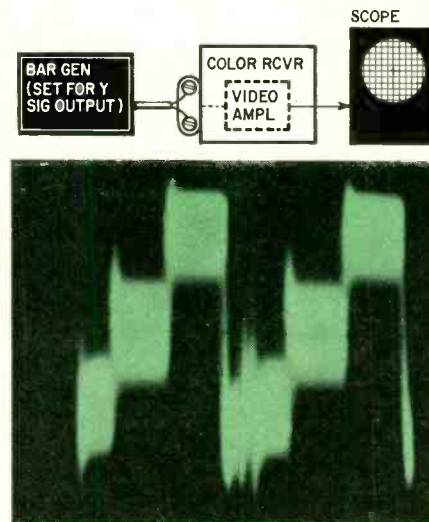

Fig. 6—This color bar waveform shows blurring caused by noise.

a desirable signal-to-noise ratio. If there are signs of overloading, adjust the age level control or clamp the age lines.

Unless this is done, the beginner may have unusual difficulty in evaluating waveforms. Most noise voltages are generated in the mixer, although the rf amplifier also make noticeable contributions. The amount of noise interference in video waveforms is determined almost entirely by the signal level at the mixer. If the generator output is increased, the signal-to-noise ratio at the mixer is also increased. The noise level itself is not significantly affected. Thus, a tenfold increase in generator output reduces the apparent noise to about one-tenth of its initial value.

Of course, this tenfold increase in signal level will overload various signal circuits following the mixer if age bias has been set for weak-signal reception. Overload shows up as compression or clipping of the signal waveforms, and is highly misleading if it goes unrecognized. If a signal waveform appears distorted, reduce generator output while watching the waveshape. If the waveform remains the same, but merely becomes noisier, the trouble is actually in the receiver circuits. On the other hand, if the waveform changes in shape and becomes more nearly normal, the trouble is due to overload in one or more of the stages. END



...you're sure of getting what you ask for in *Radio-Electronics*. For over five years we have insisted that mail-order tube advertisers state plainly whether their tubes are new, or seconds or rejects—as the case may be. This has cost us some advertising revenue—but it has protected you.

you can have a career like this in space age electronics

Take the first step today—send for free book that shows you how CREI can help you take advantage of today's opportunities.

JUST A FEW YEARS AGO Robert N. Welch had a routine job in electronics. He realized that progress was impossible without practical and up-to-date knowledge of advanced electronic engineering technology. Determined to prepare himself to meet industry requirements for career opportunities, he enrolled in a CREI Home Study Program. Today he is a Philco Corp. engineer with a responsible assignment in space age electronics at Vandenberg Air Force Base, launching site for inter-continental ballistic missiles.

YOU HAVE THE SAME OPPORTUNITY. CREI offers you, for study at home, a complete program in electronic engineering technology designed to equip you with the practical knowledge of electronic developments required



SUPERVISING A FREQUENCY MEASUREMENT in the Precision Measurement Equipment Laboratory at Vandenberg Air Force Base is CREI grad Robert N. Welch. He is a Philco TechRep Engineer and a Section Leader in the Laboratory.

for well-paying positions and put you on the level of specialization where men are most in demand.

YOU WILL FOLLOW THE FOOTSTEPS of the thousands of CREI men who hold positions as associate engineers, engineering aides, field engineers, project engineers and technical representatives. They work in every area of electronics from manufacturing to research in the aero-space program.

YOU CHOOSE FROM PROGRAMS covering every important field of electronics:

SERVOMECHANISMS • INSTRUMENTATION • RADAR •
COMPUTERS • AERONAUTICAL AND NAVIGATIONAL •
COMMUNICATIONS • AERO-SPACE • TELEVISION •
AUTOMATION AND INDUSTRIAL ENGINEERING TECHNOLOGY •
NUCLEAR ENGINEERING TECHNOLOGY



MR. WELCH PARTICIPATES in a technical discussion with Charles P. Browning, Contract Manager, and Eurl W. Bowman, Electrical Calibrator and Repair Supervisor, in the Laboratory which Philco Corp. operates under contract to the Air Force.



CALIBRATION OF PRECISION MEASURING EQUIPMENT used in the missile program is performed in Mr. Welch's section of the Laboratory. He is shown making an adjustment on the oscillator which is used as a frequency standard in this important task.



MR. WELCH HAS ENJOYED promotions from Technician to Junior Engineer to Engineer since he enrolled in a CREI Program. Here he is greeted by his family as he returns to his pleasant home in Santa Maria, California at the end of the day.



HIS FAMILY SHARES IN THE REWARDS Mr. Welch has gained with the help of a CREI Home Study Program in Electronic Engineering Technology. He is shown reviewing the day's events with his wife JoAnn, and his children, Jeff and Lynn.

YOU ARE GUIDED and assisted with personal attention from CREI's staff of experienced instructors. You study courses to which a number of leading engineers and scientists have made substantial contributions.

CREI EDUCATION IS RECOGNIZED by such large corporations as Pan American Airways, Federal Electric Corp., The Martin Co., Canadian Broadcasting Co. and Mackay Radio. They pay all or part of CREI tuition for their employees.

CREI HAS 35 YEARS OF EXPERIENCE in advanced technical education through home study. CREI has developed electronics courses for the Army Signal Corps, special radio technician courses for the Navy and group training programs for leading aviation and electronics companies. CREI also maintains a Residence

School in Washington, D. C. and invites inquiries from high school graduates.

YOU CAN QUALIFY for a CREI Correspondence Program, if you have basic knowledge of radio or electronics and are a high school graduate or the equivalent. If you meet these qualifications, send for the FREE 1963 edition of our 58-page book describing CREI Programs and career opportunities in electronics. Use coupon provided, or write to:



CREI FOUNDED 1927

THE CAPITOL RADIO ENGINEERING INSTITUTE
Department 1402-A, 3224 Sixteenth St., N.W.
Washington 10, D. C.

Because you've got to
SEE it - to BELIEVE it
... we will send you
a FREE sample!!!

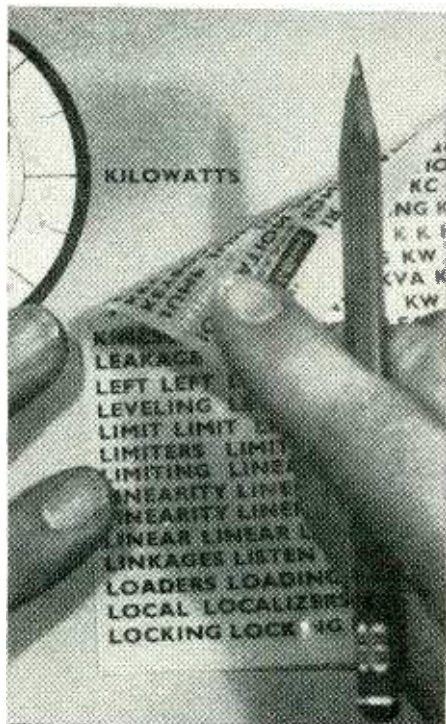

instant lettering

DRY TRANSFER TITLES FOR PROTOTYPES AND ELECTRONIC PANELS

Imagine lettering that transfers DRY to almost any surface — paper, wood, glass, metal, plastic — with just a quick, light pressure! Not just any lettering but the finest, most meticulous lettering in the world transfers from the carrying sheet to your prototypes, electronic panels, or engineering drawings.

**NOT A DECAL—NO WATER—NO TAPES
NO SCREENS — GOES ON INSTANTLY
JUST PRESS AND IT'S THERE
MAKES PROTOTYPES LOOK LIKE
FINISHED EQUIPMENT!**

Complete "Instant Lettering" Title Sets contain 24 sheets with thousands of pre-set words and phrases researched to give you the greatest variety and flexibility.

No. 958—Black\$4.95
No. 959—White 4.95

Now in stock at Allied, Lafayette, Newark, Harvey Radio and other selected electronic distributors.

WRITE - WIRE - PHONE FOR FREE SAMPLE!

THE DATAK CORPORATION

63 71st STREET GUTTENBERG, N. J.

N. J. 201—UN 4-6555 N. Y. 212—LA 4-0346

56

SERVICE CLINIC

By JACK DARR
SERVICE EDITOR



This column is for your service questions. We answer them free of charge and your name and address will be kept confidential if you wish. The main purpose is to help those working in electronics with their problems.

We've changed our target a little and are no longer restricted to TV, Radio, audio and industrial electronics problems are also grist for the mill. All letters get a prompt individual answer and the more interesting ones will be printed here. So if you have a service problem, send it here. We'll do our best to help you solve it.

THERE IS ONE QUALITY WHICH THE electronics technician must have at all times—impartiality while trying to diagnose trouble in an electronic circuit. Let's take an actual case where partiality hurt. Fig. 1 shows a popular vertical oscillator output circuit. The complaint is vertical instability, roll and a revolting tendency to lock the blanking bar firmly in the center of the picture. From your knowledge of this circuit, you ought to start looking for a leaky capacitor.

One run of chassis using this circuit had a poor .015- μ f capacitor in the feedback loop. It failed in many sets of this series. So, using the law of most likely suspect, we always checked that one first. We were partial to it. I walked into a shop one day and there was one of these chassis on the bench. The technician was looking at it with a sort of hurt look. He said plaintively, "I've replaced that .015, and it still won't work!"

After some conversation, we located the real culprit, a bad resistor in the vertical hold circuit. (The 150,000-ohm unit from the vertical linearity control to ground.) Now you can see the evil effects of partiality. It can slow up your diagnoses tremendously! Simply because this man was partial to that one capacitor as the cause of trouble, he refused to admit that there was

any other cause. Sitting here reading and talking about it, we can easily see that practically any part in that circuit *could* be at fault (20-20 hindsight). But when we get to the bench, unless we maintain that cool impartial attitude, progress is going to be a lot slower than it should.

Here's another good example. I was operating on an ancient Stewart-Warner, a beautifully built 9126 chassis which I've had for many years. Old Faithful developed horizontal hold trouble. When I turned the hold control, which was the core of the ringing coil, clockwise, the picture refused to lock in at all, but flipped out of sync in the other direction. Backing up, counterclockwise, I could get a pretty unstable picture or a split-picture with a blanking bar in the middle. The circuit is in Fig. 2. It's a conventional stabilized multivibrator, with a 6AL5 phase detector.

I rapidly diagnosed this as afc trouble. Only one small difficulty—all parts, pulse waveforms, etc., in the afc, checked out perfect! So, away we go. Strap out the ringing coil, raise the value of the plate resistor to about 10,000 ohms and the oscillator works pretty well. (Sync shorted out for this test, as usual.) Now back to the afc. Despite all the time I have spent saying, "Once you check a circuit and find it OK, go

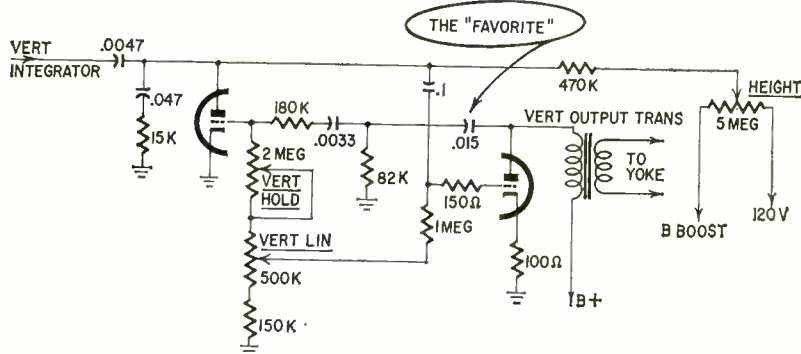

Fig. 1—Popular vertical oscillator output circuit. Any part in this circuit can cause trouble. Don't bet on the favorite being the bad component.

NOW with TRANSISTOR POWER supply



MODEL 100 A TRANSCEIVER WITH
NEW DYNAMIC MICROPHONE



CLIPPER/FILTER AMPLIFIER



EXTERNAL SPEAKER S/METER

INTERNATIONAL MODEL 100 A EXECUTIVE TRANSCEIVER

International's new Model 100 A is the latest in the outstanding line of Executive transceivers. The advanced design Executive features a *transistor power supply*, *new perforated metal cabinet*, and a *new rugged microphone* . . . all of which contribute to a more reliable mobile operation.

The Model 100 A . . . the finest of its kind, also features:

- Crystal filter for improved receiving
- Twelve crystal controlled transmit positions
- Two crystal controlled receive positions
- Dual conversion superheterodyne receiver tuning 23 channels
- Built-in calibration circuit
- N R squelch
- Provision for connecting external speaker and s/meter
- Push-to-talk operation
- Transistor power supply operates from 6/12 vdc or 115 vac

Model 100 A, complete with 1 transmit crystal, 1 receive crystal, and microphone.....\$199.50

External Speaker and S/Meter

The perfect companion for the International Executive Model 100. Utilizes a high impedance vacuum tube volt meter circuit. Connects to socket on rear of transceiver. S/meter reads in three ranges. Brown cabinet, brown and silver panel matches Executive transceiver.

Complete with interconnecting cable.....\$49.50

Executive Speech Clipper/Filter Amplifier

A microphone amplifier designed to increase average modulation . . . limits modulations peaks . . . filters

audio frequencies above 2500 cycles. Permits arms-length microphone operation. Power requirements: 12 vac or 12 vdc.

Complete with interconnecting cable.....\$36.50

12.6 VAC, 2 Ampere Power Unit

Base station power unit for Speech Clipper/Amplifier. Operates from 115 vac. Provides 12.6 vac at 2 amperes.

Complete with mounting chassis, power cord, fuse, switch.....\$12.50

Citizens Band licensees with International equipped stations know the unquestioned superiority and advantages of Executive transceivers and their system engineered accessories.

See your authorized International dealer today.





NOW
YOU CAN BUILD
A FINE
Schober Organ
FOR ONLY
\$550

You can assemble this new Schober Spinet Organ for \$550 — or half the cost of comparable instruments you have seen in stores. The job is simplicity itself because clear, detailed step-by-step instructions tell you exactly what to do. And you can assemble it in as little as 50 hours.

You will experience the thrill and satisfaction of watching a beautiful musical instrument take shape under your hands. The new Schober Electronic Spinet sounds just like a big concert-size organ — with two keyboards, thirteen pedals and magnificent pipe organ tone. Yet it's small enough (only 38 inches wide) to fit into the most limited living space.

You can learn to play your spinet with astounding ease. From the very first day you will transform simple tunes into deeply satisfying musical experiences. Then, for the rest of your life, you will realize one of life's rarest pleasures — the joy of creating your own music.

For free details on all Schober Organs, mail the coupon now. No salesman will call.

THE *Schober Organ* CORPORATION

43 West 61st Street, New York 23, N. Y.

Also available in Canada and Australia.

MAIL THIS COUPON TODAY

The Schober Organ Corporation
Dept. RE-23
43 West 61st Street
New York 23, New York

- Please send me FREE booklet and other literature on the Schober Organs.
- Please send me the Hi-Fi demonstration record. I enclose \$2 which is refundable when I order my first kit.

Name.....

Address.....

City..... Zone..... State.....

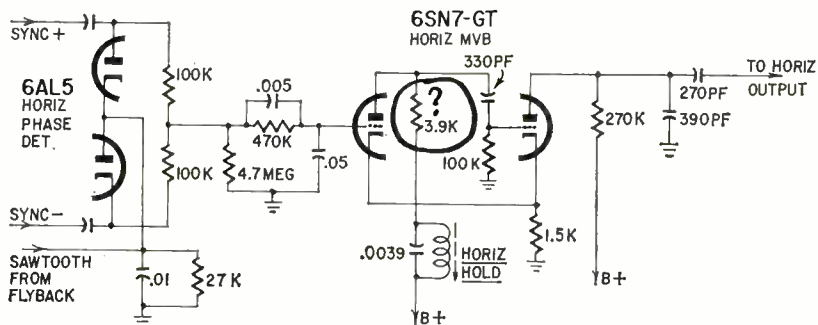

Fig. 2—Partial circuit of horizontal oscillator-afc circuit of Stewart-Warner 9126. This too has a number of possible trouble spots.

on to another." I went back and rechecked the afc! I was partial to my original theory (spelled g-u-e-s-s).

After a couple of days, I looked at the stubborn thing and said, "Well, there's only one resistor I haven't checked out (the 3,900-ohm unit between the ringing coil and plate). Now, everyone knows that the size won't affect the operating frequency of the oscillator. I've changed this in many sets without trouble. But, I'm going to check you anyhow, since you're the only part in the circuit that I haven't checked!" It was about 8,000 ohms, so I replaced it. You know what happened. The set worked beautifully.

The point I want to make is that I was so partial to the idea that the trouble was in the afc that I couldn't see the slightest possibility of it being anywhere else. This cost me roughly a day and a half of work. If I had been impartial enough to give up the idea of afc trouble as soon as I'd checked out that circuit and gone on from there, the total job time would have been about 2 hours instead of 2 days.

The original diagnosis was good. From the symptoms, it was afc trouble. Where I erred was in being so partial to this theory that I couldn't let go.

The conclusion to draw from these experiences is: "Always keep that mind open!" Make your first tests based on the probability of the cause, from the symptoms. But always remember that they can mislead you. With a completely open mind you can realize that your first diagnosis is not right, no matter how good it seems, and go on to make impartial tests of other circuit components.

One final example, and I'll stop. A

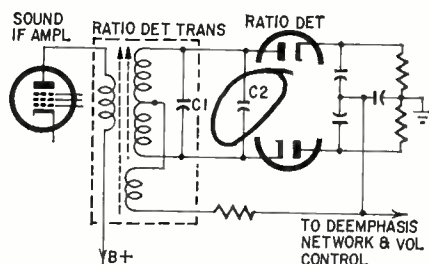

Fig. 3—Ratio-detector circuit used in some portables. Too many capacitors led to poor sound.

small TV set came in with very bad sound. The ratio detector transformer was replaced with a high-quality standard replacement transformer, not a factory duplicate. Still, poor sound.

Signals traced out fine up to the transformer input. It would not adjust properly. No crossover in the secondary, just a positive voltage, very small. Still, because the transformer was new, correctly installed and high-grade, I thought it was OK. I was very partial to this make of transformer.

Fig. 3 shows the real trouble. The original circuit used a ratio-detector transformer with the resonating capacitor (C2) for the secondary outside, on the printed-circuit board. This capacitor (C1) was inside the replacement transformer. Being blinded by partiality, I couldn't see the possibility of any trouble in or around that transformer, so I didn't look. When I had exhausted all other alternatives, I looked, and there it was. Disconnecting the external capacitor (C2) restored normal sound.

Wasted time on this job, several hours. So watch out for partiality. It's fine in politics, football games and love, but it doesn't go in electronics service.

Replacement flyback

I've been working on a Bendix TM-21CS TV, and I need a new flyback transformer, part 265086-1. Various manufacturers list replacements, but they're all autotransformers, while the original is a transformer type. Can you suggest a good replacement or give me a hand in redesigning the set?—R. A. C., Jr., West Point, N. Y.

A Triad D-114 flyback seems to be about your best bet here. It is a transformer type and is listed as an exact replacement. I don't think you will have to redesign the set.

Three-inch picture

The RCA KCS-47 on my bench has a picture that is about 3 inches wide. I can adjust it to about 4 inches in width. I have checked all the voltages and they are ok. Changing tubes doesn't affect the trouble.—R. McA., Long Beach, Calif.

This defect means trouble in the horizontal yoke. I ran into the same thing on a couple of other sets with

the same chassis. There is no keystone and the brightness is good. However, the fact that there is high voltage, and the picture can (usually) be locked in, indicates that the flyback, oscillator, etc., are ok and that the whole trouble lies in just a plain lack of horizontal sweep. This does not seem to show up as a bad capacitor or resistor in the damping network but rather as a peculiar short in the windings. The yoke will test bad on a flyback-yoke tester. Replace it and see if this doesn't cure the trouble.

Retrace lines

There are thin white lines running from upper right to lower left on a Philco 52T1802 (Code 124). I can almost get rid of them by adjusting contrast and brightness.—F. K., Millington, Tenn.

They are vertical retrace lines. You can get rid of them by blanking

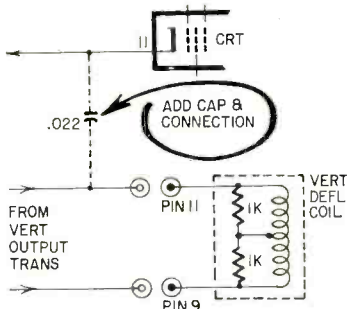

Fig. 4—To add retrace blanking to a Philco 52T1802, tap off blanking pulses at pin 10 of the chassis interconnection plug and feed them to the CRT cathode.

the picture tube during vertical retrace time. Do this by feeding a spike or voltage into the CRT to cut it off during this period.

Connect a .022-μf capacitor between pin 11 of the chassis interconnecting plug, which is the top of the vertical deflection coil, and the CRT cathode (Fig. 4). This will feed in a suitable blanking spike.

Silicon for selenium

Can I replace the selenium rectifiers in a typical TV power supply with silicon rectifiers? If so, will the original surge resistor be adequate? What problems would I encounter?—C. W. F., San Diego, Calif.

There are a few things to watch out for but in general, yes. First thing is the condition of the input electrolytic filter. You'll get a slightly higher B-plus with silicons, because of their lower forward resistance. In some cases you can compensate for this by increasing the surge resistor slightly. Best way is to add a surgistor or one of the small time-delay relays, as used by RCA and others, in the B+. It prevents the ap-

(Continued on page 62)

NEW! WINEGARD NUVISTOR ANTENNA AMPLIFIER



ENGINEERED FOR TROUBLE-FREE,
LONG LIFE OPERATION...

NO CALL BACKS!

INSTALL IT AND FORGET IT... USES 2 NUVISTORS THAT WILL LAST FOR YEARS... COMPLETELY WEATHER-SEALED, WON'T CORRODE... RESPONDS TO WEAKEST SIGNALS BUT STRONG SIGNALS WON'T OVERLOAD IT (TAKES UP TO 400,000 MICROVOLTS INPUT)... NOT AFFECTED BY HEAT OR COLD... DESIGNED FOR COLOR TV... FITS ANY ANTENNA... FULLY PROTECTED FROM LIGHTNING FLASHES, PRECIPITATION STATIC AND LINE SURGES ON 110 VOLT LINES.

Uppermost in the minds of Winegard engineers in developing the new Colortron amplifier were two things—1. A new high in performance. 2. Long life and trouble-free operation. For example, a special "lifesaver" circuit gives the two nuvistors an expected life of 5 to 8 years at top performance. This is possible because of a heat sink to control operating temperature and an automatic voltage control.

Winegard's revolutionary new circuit enables the Colortron to overcome the service problems and limitations of other antenna amplifiers. Colortron will not oscillate, overload or cross modulate because it takes up to 400,000 microvolts of signal input. This is 20 times better than any single transistor amplifier.

The Colortron amplifier will deliver clean, clear, color pictures or black and white, sharp and bright without smear. It can be used with any good TV antenna but will deliver unsurpassed reception when used with a Colortron antenna.

It has an ultra low noise circuit... high amplification... flat frequency response... accurate impedance match (VSWR 1.5 to 1 or better, input and output)... and no phase distortion. Can drive 6 sets or more easily.

Nothing on the amplifier is exposed to the elements—even the terminals are protected. A rubber boot over the twin-lead keeps moisture out. Colortron comes complete with an all AC power supply with built-in 2 set coupler. Colortron (model No. AP-220N) lists at \$39.95. Twin transistor model AP-220T also available. Input 80,000 microvolts without overload—\$39.95. For FM model, AP320 twin Nuvistor, 200,000 microvolts input—\$39.95.

Colortrons will be heavily promoted this fall with big ads in Life, Family Weekly, Parade and other consumer publications. Order now—ask your distributor or write for technical bulletin.

You get an extra bonus of quality and performance in all Winegard products.



AMPLIFIER WORKS ON ANY ANTENNA.



SPECIALLY DESIGNED AMPLIFIER CLAMP SNAPS ON COLORTRON ANTENNA IN SECONDS.

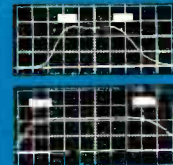

UNRETOUCHED PHOTO OF AMPLIFIER GAIN CURVE—FLAT RESPONSE ALL CHANNELS.



COLORTRON POWER UNIT WITH BUILT-IN 2 SET COUPLER.



AS OF OCTOBER 22, 1962—THE

(*it ended the day JFD introduced the Log-Periodic **LPV** $\frac{L(n+1)}{L_n} = \tau$ TV antenna)

Wave goodbye to all the Rube Goldberg contraptions with their "Chinese puzzle" combinations of collectors, directors, reflectors.

Now you can solve any reception problem with one compact, precisely-engineered antenna—the first TV antenna based on the geometrically-derived logarithmic-periodic scale developed by the Antenna Research Laboratories of the University of Illinois for the U.S. Air Force.

Because it is inherently frequency-independent, the JFD Log-Periodic LPV delivers the same superb performance on every VHF channel—performance comparable to that of a single channel Yagi. And delivers it not only in black-and-white, but in Color, and you get FM stereo too!

THE LOG-PERIODIC LPV ACTUALLY TUNES ITSELF TO EACH RECEIVED FREQUENCY—RESULTING IN:

- HIGHEST GAIN—as high as 14 db. in the LPV 17!
- SHARPEST DIRECTIVITY—on high bands as well as low!
- HIGHEST FRONT-TO-BACK RATIO—up to 35 db.
- LOWEST VSWR—as low as 1.2 to 1—with constant impedance across the full bandwidth!
- FLAT RESPONSE ACROSS BOTH VHF BANDS—with greater gain on the high band, where it's needed most (average increase of gain in high band over low band: 3¼ db.)!
- BROADEST BANDWIDTH—thanks to its unique frequency-independent characteristics!

FOR THE FIRST TIME ONE SCIENTIFICALLY FORMULATED ANTENNA CONFIGURATION SATISFIES ANY LOCATION DEMAND: Harmonically resonant V-elements operate on the Log-Periodic Cellular Principle in the Fundamental and Third Harmonic Modes for unprecedented performance —in color—in black and white—in FM STEREO

developed by the Famous Antenna Research Laboratories

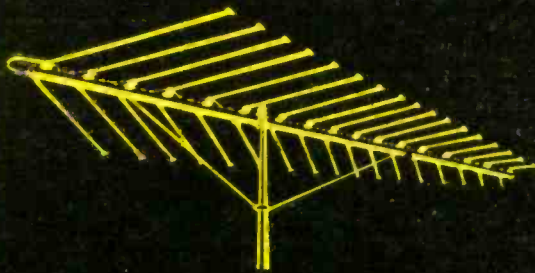

LPV-17: 15 Active Cells and Director System—up to 175 miles

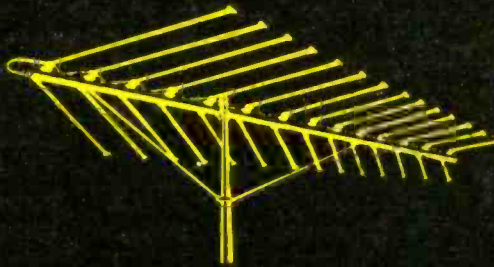

LPV-14: 13 Active Cells and Director System—up to 150 miles



LPV-11: 9 Active Cells and Director System—up to 125 miles

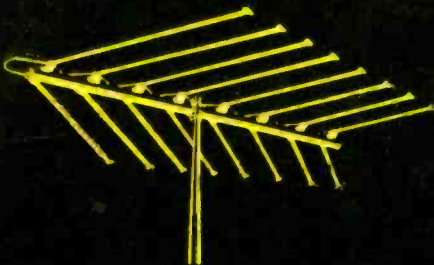

LPV-8: 7 Active Cells and Director System—up to 100 miles



LPV-6: 6 Active Cells—up to 75 miles

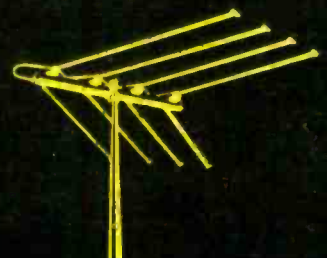

LPV-4: 4 Active Cells—up to 50 miles

Adapted to TV and FM Stereo by JFD

- ✓ ELIMINATES THE NEED FOR AREA-DESIGNED ANTENNAS
- ✓ 100% PREASSEMBLED "FLIP-QUIK" ASSEMBLY
- ✓ MASSIVE TANK TURRET BRACKETS THAT DOUBLE-LOCK ELEMENTS
- ✓ AAA† GOLD BOND ALODIZED TO KEEP THAT BRAND NEW LOOK
- ✓ EXTRA-RUGGED, DOUBLE-REINFORCED IN EVERY DETAIL
- ✓ LIGHTEST IN WEIGHT PER DB GAIN
- ✓ WIND-TUNNEL TESTED CONSTRUCTION
- ✓ LEAST SNOW AND ICE LOADING

†Attractive, Anti-corrosive Armor

'ERA OF COMPROMISE' IS OVER!*



LPV-11

of the University of Illinois* Proved in Space Satellite Telemetry

HOW THE LOG-PERIODIC LPV MAKES ALL OTHER ANTENNAS OBSOLETE

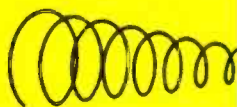

The JFD LPV antenna is a direct descendant out of the logarithmic conical spiral antenna used on the Transit satellite. This basic design is **FREQUENCY INDEPENDENT**—it works like a conical waveguide to yield almost constant gain, matched impedance and a unidirectional polar pattern across an extremely wide band of frequencies.

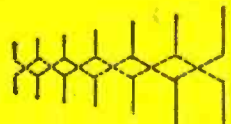

Dipole version of spiral antenna has elements whose length and spacing is determined by formula derived from conical spiral geometry, so that antenna acts like a spiral with parts of coils missing. A logarithmic scaling multiplier ties the dipoles together into active multi-element cells for each frequency. Crossed phasing harness inserts a 180 degree phase shift between dipoles that cancels signals from rear, reinforces signals from front.

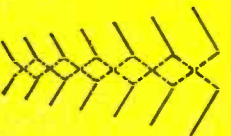

JFD's LPV antenna for TV and FM goes one step further—increases gain and front-to-back ratio while maintaining frequency independence. Forward V-ing of elements shrinks rear radiation lobes, narrows forward beam for sharp directivity, helping to eliminate ghosts and adjacent channel interference. Forward V also permits low band dipoles to contribute to high band gain by operating on the third harmonic mode.

For example: Operation of the JFD LPV-11 on the low band: The larger dipole cells resonate to the low band TV frequencies at their fundamental wavelength. Within each cell, one dipole absorbs the greatest amount of signal for any particular channel, adjacent dipoles pull in 60% more and the next two dipoles add 30% more signal. Many active dipoles working on each channel with constant impedance guarantee high gain.

--- indicates current distribution on fundamental mode.

On the high band: The third harmonic cell forms at the rear of antenna for channel 7 and as the frequency increases toward channel 13, the active region moves toward the apex of the antenna. It is this third harmonic operation which guarantees as much as 3 1/2 db. additional gain. Continuous and co-linear directors sharpen forward pattern and give peak performance across the entire VHF TV band.

--- indicates the current distribution for the third harmonic mode which will be received on all elements.

..... indicates the active region for channel 10, i.e., the different efficiencies with which the elements of the LPV-11 act on channel 10.

The actual gain curves measured for the LPV-11 in the JFD Antenna Research Laboratories confirm this fact: Within the band for which it is designed (the principle will also be adapted for UHF and other uses), the log-periodic LPV's impedance, polar patterns and front-to-back ratio are virtually constant—with gain for each channel as high as that furnished by a comparable-sized single-channel Yagi.

FUNDAMENTAL MODE

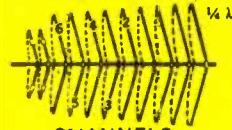

CHANNELS

THIRD HARMONIC MODE



CHANNELS

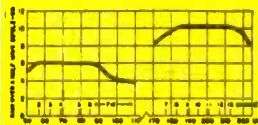

Each antenna in the LPV series consists of an array of resonant V-dipoles and crossed phasing bars, constituting a group of "cells." The size of each cell differs from the one before it by a Logarithmic factor. For any particular frequency, the active portion of the antenna centers on the resonant dipole (equal to one-half wavelength at that frequency), with the adjacent elements also absorbing significant signal energy. The resonances of adjacent cells overlap, so that as the frequency increases or decreases, it is transferred smoothly from one cell to the next.

In effect, the signal is passed along as the frequency increases—the active area moving toward the apex or small end—until, as the fundamental harmonic reaches one end, the other end approaches resonance in the third harmonic. Conventional wide-band antennas are like rows of compartments, one for each channel desired, with sharp cutoffs. The log-periodic antenna is like a continually moving belt that accepts smoothly any frequency that hups aboard.

*U.S. Patents 2,958,081—2,385,879—3,011,168. Additional Patents Pending. Produced exclusively by JFD Electronics under license to University of Illinois Foundation.

SEE THE JFD LOG-PERIODIC LPV AT YOUR JFD DISTRIBUTOR NOW—AND BE THE FIRST ONE IN YOUR AREA TO INTRODUCE AND PROFIT FROM THIS NEW ERA IN TV RECEPTION.

THE BRAND THAT PUTS YOU IN COMMAND OF THE MARKET

JFD

JFD ELECTRONICS CORPORATION

15th Avenue at 62nd Street, Brooklyn 19, N.Y.

JFD Electronics-Southern Inc., Oxford, North Carolina

JFD International, 15 Moore Street, New York, N.Y.

JFD Canada, Ltd., 51 McCormack Street, Toronto, Ontario, Canada

401-144 W. Hastings Street, Vancouver 3, B.C.

CITIZEN BAND STANDARDS BY SONAR

When performance is critical and reliability a necessity SONAR CAN BE DEPENDED UPON. Citizen Band standards of Sonar must and will always be above and beyond what is expected. Write for full particulars.



MODEL E FCC type accepted • 8 channels, crystal-controlled transmitter/receiver • Tunable receiver for 23 channels • Powerful transmitter 100% Class B modulated • Automatic noise limiter • Lightweight, compact. **\$179.50**



MODEL G Dual conversion • RF output meter • Signal strength meter • Crystal spotting switch • Illuminated panel • 8 channels crystal-controlled • Receiver tunes 23 channels • Class "B" modulation • Featuring the NEW Sonar noise silencer. **\$229.50**

SONAR RADIO CORPORATION, 73 Wortman Ave., Brooklyn 7, N.Y.



Please send me complete information on Dept. 221
 Model E Model G
 NAME.....
 ADDRESS.....
 CITY.....STATE.....

FANTASTIC VALUE IN CLOSED CIRCUIT TELEVISION

BRAND NEW—COMPLETE SYSTEM SHOWN
 Fraction of Mfg. Resale Price

Low—Low \$495.00

Complete system with all tubes—wired and tested. Less Vidicon and Lens—with Schematics (connecting cables and plugs only—supplied, but not assembled)



Only \$649.50

Complete system with test vidicon, 1-inch lens, and assembled cables, schematics, wired and tested.

CONTROL MONITOR

12 Tubes & 21DAP4

CAMERA

4 Tubes and VIDICON

POWER SUPPLY

11 Tubes & Transistor—31.5 Kc Crystal Controlled Oscillator 115 V-AC, 60 cycles.

EIA Standards of 525 lines, 60 Fields, 30 Frames and 2:1 interlace—Aspect Ratio 7:3
 Capable of 700 lines Horizontal resolution and 350 Lines Vertical.

Write for Catalog #1273RE—"HOW TO BUILD LOW COST TV CAMERAS," Industrial and Broadcast Cameras and equipment, Miscellaneous accessories, lenses, tripods, etc. **ONLY 50¢**

DENSON ELECTRONICS CORP., Box 85, Rockville, Conn., Tel.: TRemont 5-5198

(Continued from page 59)
 plication of B+ to the set until the tubes have warmed up.

In some old sets, we deliberately replace selenium with silicon to get a wee bit more B+ for added width, etc.

Pips and blips

In a Philco 22B4400 TV, I get a peculiar blip on the vertical oscillator grid waveform (Fig. 5). It moves up the sawtooth and, when it hits the top, the picture rolls. I'm not sure what it is or even that I'm using the right scope probe.—F. S., Pensacola, Fla.

You're using the right probe, ob-

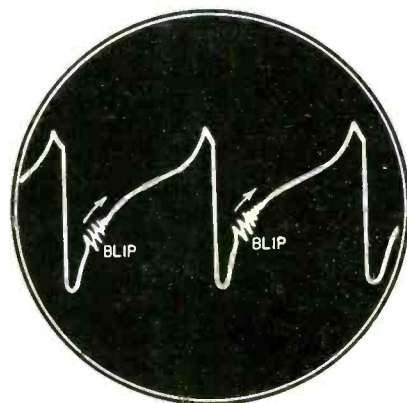

Fig. 5—If the blip on the vertical sweep waveform does not crawl when scope sweep is synchronized to the line the trouble must be in the set's power supply.

viously (the low-capacitance probe), or you wouldn't even see the blip. This must be some sort of spike voltage getting into the vertical oscillator. This is 60 cycles, but not quite in phase with the vertical oscillator. If it were leakage from the vertical output, it would not move or crawl. Therefore, it must be from the 60-cycle ac power supply somewhere.

To check this, set the scope sweep on "line" and recheck the waveform. If the blip stands still and the waveform crawls, then it is definitely local power supply frequency. The most common cause of this is a glitch (a small spurious peak) in the filter system caused by open line bypass capacitors, slight trace of gas in one of the rectifier tubes or a defective filter capacitor. **END**

Correction

A ground was inadvertently omitted from pin 3 of the 6X4 rectifier in Fig. 1 of the article "High-Fidelity TV Sound" on page 29 of the December issue. Add this ground to complete the heater circuits of all tubes except the 6X4.

The B— plus current drain is 29 ma, not 40 ma as on the diagram.

What's Your EQ?

(These are answers—See puzzles p. 47)

Efficient Measurement

The assistant takes one resistor from box A, two from B, three from C, four from D, connects them in series and applies the ohmmeter as shown.

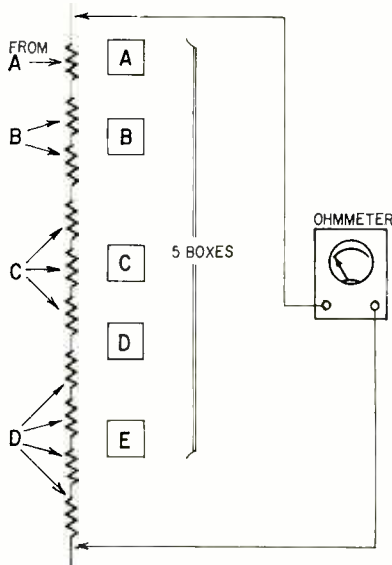

If the series runs 100 ohms over 22,000 ohms, box A is the mismarked one; 200 ohms high points to B; 300 to C, and 400 to D. If the series is exactly 22,000 ohms, obviously E is the high box.

Open Circuit

Use Thevenin's theorem. Assume a Thevenin voltage source and a series Thevenin resistance. With output shorted, $V = RI$, $V_t = 5Rt$. With the series resistor inserted, $V_t = 3Rt + 32$. Substituting, we find that $5Rt = 3Rt + 32$.

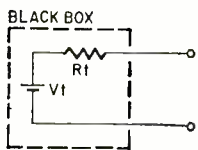

Thus $2Rt = 32$, and $Rt = 16$ ohms. Going back to our original, $R = 16$ ohms, $I = 5$ amperes. V , then, equals 80 volts. If no current is drawn, there is no drop across Rt , output voltage is 80.

Lights and Chicken Farmer

The drawing is self-explanatory.

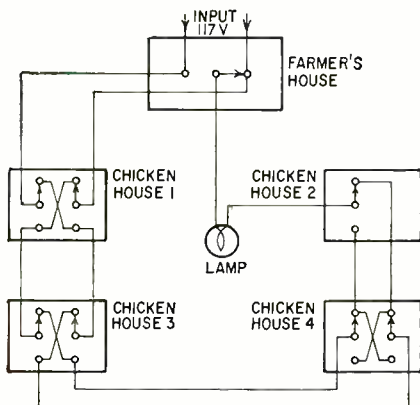

FEBRUARY, 1963

SAVE CUSTOMERS MAKE MONEY

THE INDUSTRY'S STANDARD

Most Widely Used Today
by Professional Servicemen



FAMOUS DELUXE **B&K** CRT 440



For Black & White and Color

"Most valuable and useful" . . . "Wouldn't be without it" . . . "Pays for itself over and over again" . . . servicemen say. Quickly checks and corrects television picture tube troubles in a few minutes right in the home without removing tube from set. Gives new life to weak or inoperative tubes. Checks for leakage, shorts, open circuits and emission. Removes inter-element shorts and leakage. Repairs open circuits and low emission. Restores emission and brightness. Life Test checks gas content and predicts remaining useful life of picture tube. Makes new tube sales easier. Completely self-contained. Rich leatherette-covered carry-case. Net, \$74.95

- TESTS AND REJUVENATES all picture tubes at correct filament voltage from 1 to 12 volts
- TESTS AND REJUVENATES 110° tubes and the new 19" and 23" tubes
- TESTS AND REJUVENATES color picture tubes. Checks each gun of color tube separately

UP-DATE YOUR B&K CRT WITH THESE ACCESSORIES

Subscribe to New Picture Tube Information Service

- Model C40 Adapter.** For use with previous Models 400 and 350 CRT's—to test and rejuvenate TV color picture tubes and 6.3 volt 110° picture tubes. Net, \$9.95
- Model CR48 Adapter.** For use with previous Models 400 and 350 CRT's—to test and rejuvenate 110° picture tubes with 2.34, 2.68, and 8.4 volt filaments. Net, \$4.95

See Your B&K Distributor, or Write for Catalog AP20-E

B&K MANUFACTURING CO.

Division of DYNASCAN CORPORATION
1801 W. BELLE PLAINE AVE • CHICAGO 13, ILL.
Canada: Atlas Radie Corp., 50 Wingold, Toronto 19, Ont.
Export: Empire Exporters, 253 Broadway, New York 7, U.S.A.



GUARANTEED!

OUTPERFORMS SPEAKERS COSTING FIVE TIMES MORE OR YOUR MONEY BACK!



the KENT all new...all wood only \$19.95

FEATURES AND SPECIFICATIONS

24" wide, 10" high, 9" deep; 8" high compliance woofer; 3" hardened tweeter cone, coaxial wound 1" voice coil; silicone treated edge allows for 3/4" cone displacement; Alcomax III 1-lb. 5-oz. magnet; 10,000 gauss flux density; 8 ohm impedance; zero external magnetic field; 40-18,000 cps; up to 30 watts power capacity; 1450 cubic inch volume; Fibreglass acoustic dampening; matched for stereo.

ORDER NOW to insure prompt delivery! This remarkable speaker is not available in retail stores. Direct factory sales only. . . and you save a bundle. Price—\$19.95 F.O.B. factory. Shipping weight 18 pounds.

Anglo American Acoustics Ltd. RE 63-2
129 Maryland Ave., Freeport, New York
Gentlemen: Enclosed is my check for \$
Please ship me "Kent" natural wood cabinet speaker(s) at \$19.95 each.
I UNDERSTAND THAT THESE SPEAKER SYSTEMS ARE GUARANTEED AND IF I AM NOT COMPLETELY SATISFIED I MAY RETURN FOR A FULL REFUND WITHIN TEN DAYS AFTER RECEIPT.

NAME
ADDRESS
CITY ZONE STATE

industry...

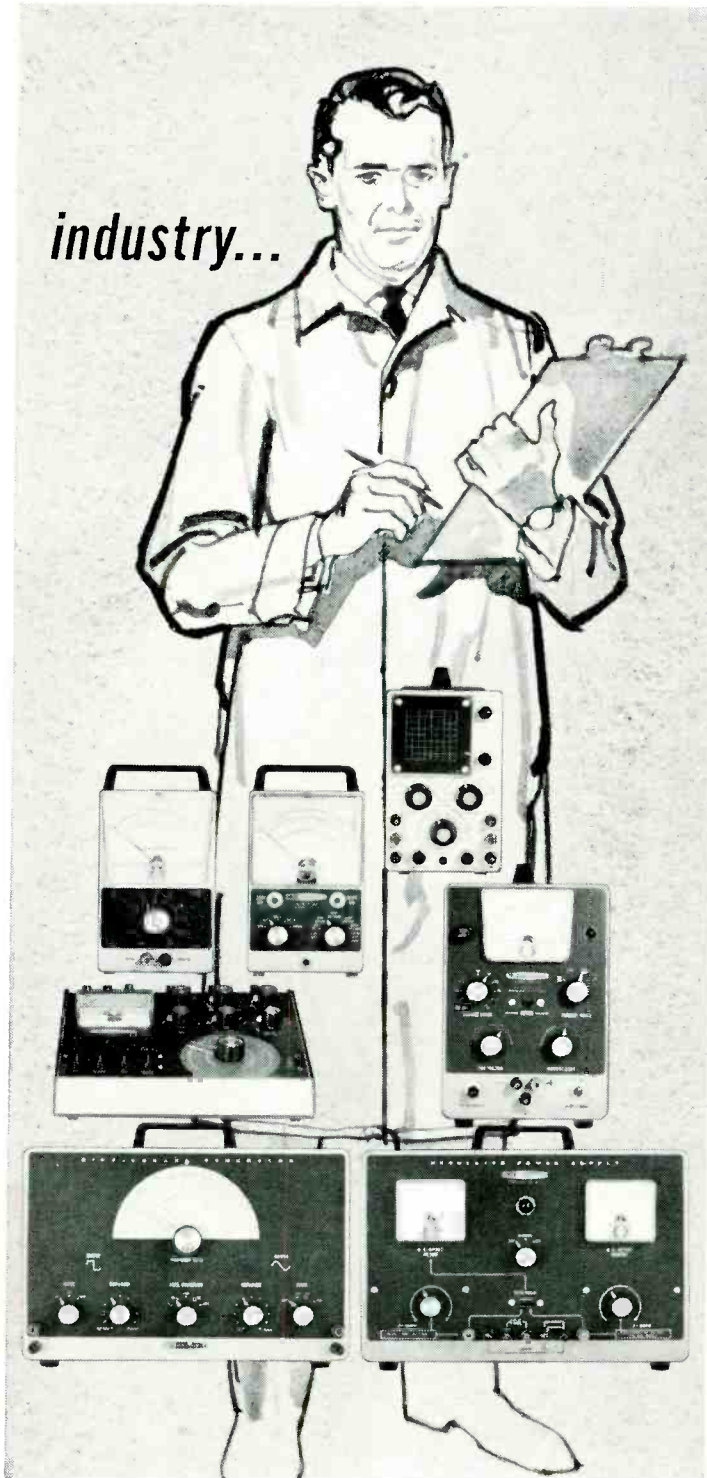

technicians...

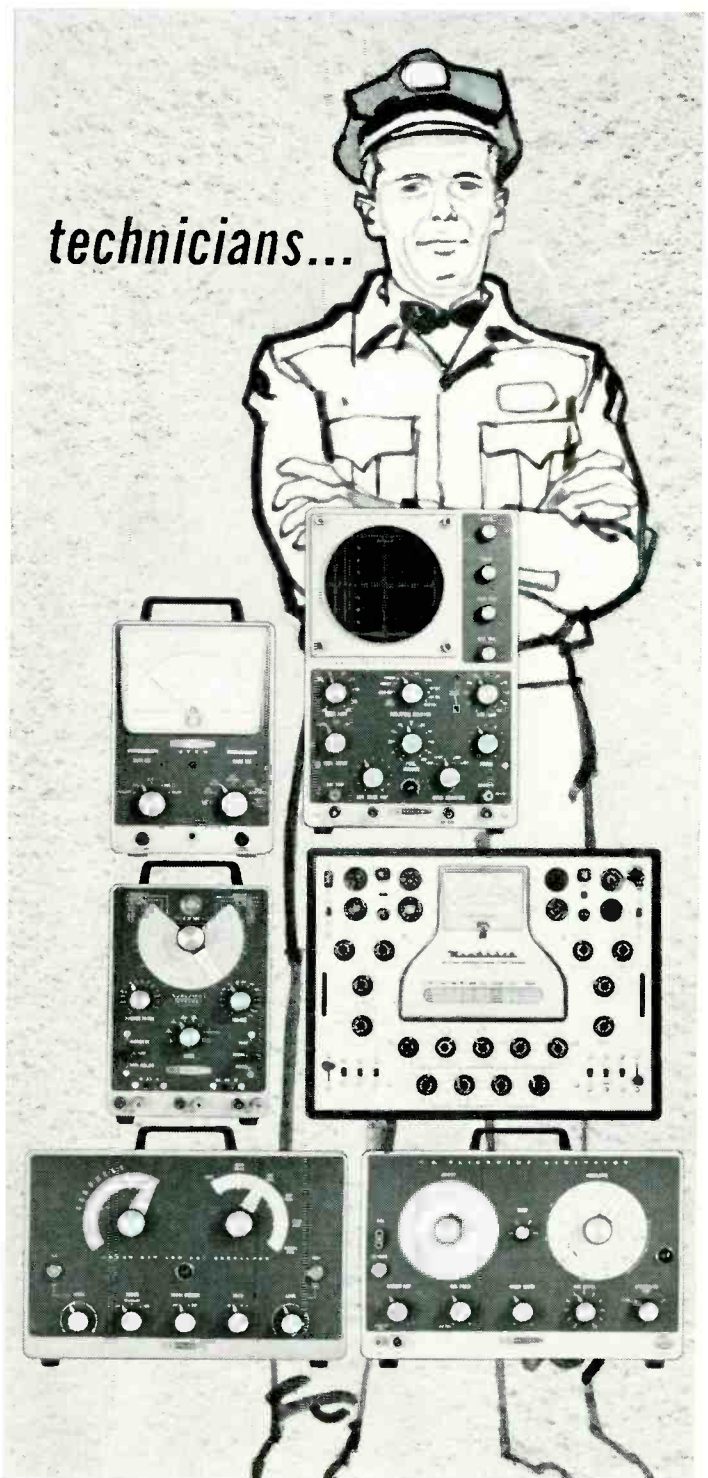

all find Heathkit® test equipment quality and

Industry Production and Design professionals put Heathkits to work in their factories and laboratories for high performance at low cost. Typical Heathkits used are: IO-10 3" DC Oscilloscope, \$79.95 . . . IM-11, world's largest selling Vacuum Tube Voltmeter, \$24.95 . . . IG-82, Sine & Square Wave Generator, \$51.95 . . . IP-32, Variable-Voltage Regulated Power Supply, \$56.95 . . . IP-20, Hi-Current, All-Transistor, Regulated Power Supply, \$72.95 . . . IM-30, Laboratory Transistor Tester, \$54.88 . . . IM-21, Vacuum Tube Voltmeter for precision AC measurements, \$33.95.

Technicians around the world put Heathkits on their service benches for rapid, precision measurements . . . complete trouble-shooting facilities at lowest cost. Typical Heathkits used are: IM-32, Service Bench Vacuum Tube Voltmeter, \$32.95 . . . IO-12, Wide-Band 5" Oscilloscope, \$76.95 . . . TT-1A, Mutual Conductance Tube Tester, \$149.95 . . . IG-62, Color Bar and Dot Generator for Color TV servicing, \$64.95 . . . IG-52, TV Alignment Generator, \$54.95 . . . IT-11, Deluxe Capacitor Checker to test capacitors of all types, \$29.95 . . . See the complete line in the Heathkit Catalog.

hobbyists...

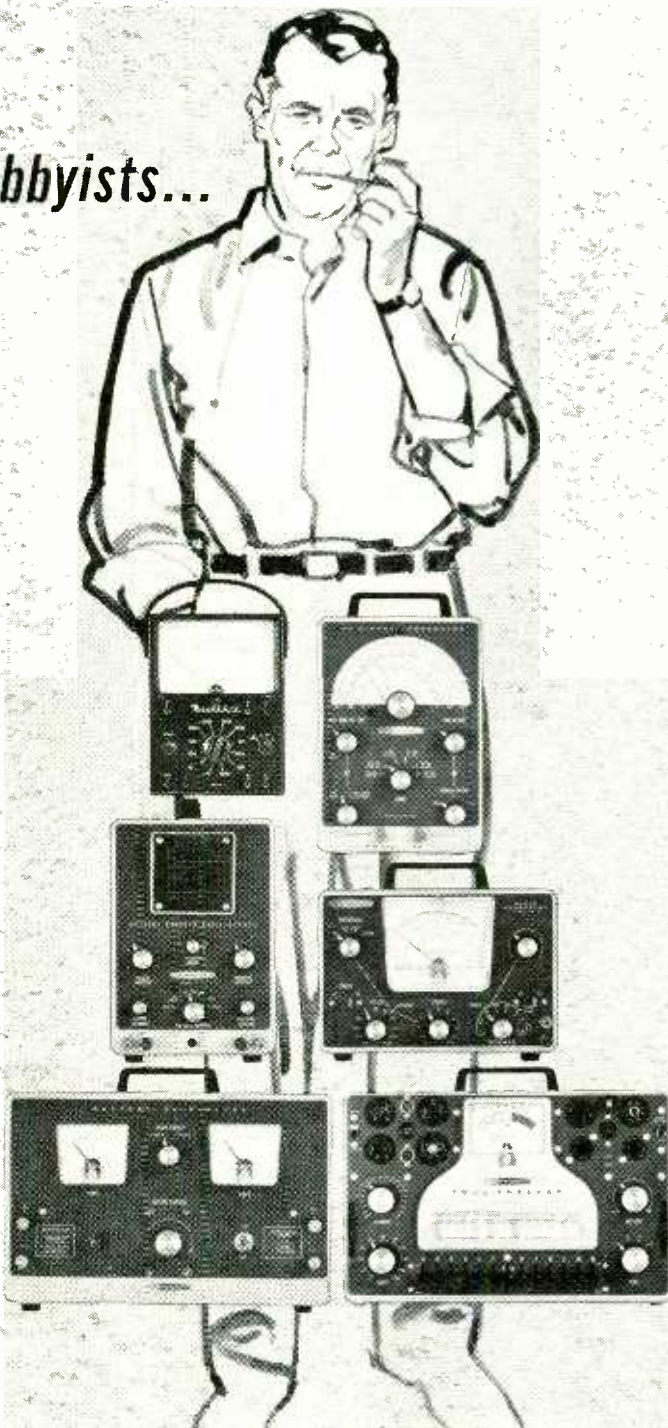

economy stacks up best

Hobbyists of all kinds find Heathkit test equipment invaluable for pursuing their hobbies with refined techniques. Audiophiles, amateur radio operators, kit builders of all kinds use these Heathkits in their workshops: IO-21, General Purpose 3" Oscilloscope, \$49.95... MM-1, Sensitive Volt-Ohm-Milliammeter for all-purpose measurements, \$29.95... IT-21, Tube Checker for fast tests of tubes of all types, \$44.95... IG-102, Radio Frequency Signal Generator, \$27.95... IG-72, Audio Signal Generator, \$41.95... IP-12, Low Ripple Battery Eliminator, \$47.50.

Who is Heathkit?

Heathkit is the pioneer and world's largest manufacturer devoted exclusively to the design and manufacture of do-it-yourself electronic kits. All our efforts are aimed at creating more kits, better kits, easier-to-build kits.



What are Heathkits?

Heathkits are electronic equipment in un-assembled form. All parts are packaged in convenient groups and complete, easy-to-read, well-illustrated instruction manual tells you how to put them together. Heath offers over 250 kits from simple portable radios to big analog computers.



Who builds Heathkits?

Millions build Heathkits. People with absolutely no mechanical ability or knowledge of electronics as well as skilled electronic experts—all find value, economy, fun, relaxation, and pride of accomplishment in Heathkits. You can too.



Money Back Guarantee

Heath Company unconditionally guarantees that each Heathkit[®] product assembled in accordance with our easy-to-understand instruction manual must meet our published specifications for performance or your purchase price will be cheerfully refunded.

The famous Heathkit guarantee—This money back guarantee stands behind every Heathkit. It guarantees that you are getting equipment of the highest quality that will provide years of use and pleasure. Equipment second to none. Heathkit—world pioneer in the exciting hobby of kit building.



FREE 1963 Heathkit Catalog. Send for your free copy of this new Heathkit Catalog... it describes and illustrates the complete Heathkit Test Instrument line... units for every purpose... units of highest quality at lowest cost.

HEATHKIT

by Daystrom

HEATH COMPANY
Benton Harbor 20,
Michigan

Please send my free 1963 Heathkit catalog

NAME _____

ADDRESS _____

CITY _____ ZONE _____

STATE _____

technician shortage worsens

THE UNITED STATES, ALREADY SHORT A million and a half electronic technicians, may find that shortage increasing to two and a quarter million by 1970. This was the consensus of a panel of specialists assembled to discuss the problem by the Cleveland Institute of Electronics. The session, held at New York City, heard reports by Dr. Glenn Bryan, head of personnel and training research, Office of Naval Research; Ralph Gunter, Radiation, Inc., missile component manufacturer; George Maedel, president, RCA Institute, and Joseph De France, N. Y., Community College.

The lack of technicians is already showing serious effects in both industry and engineering. An engineer, in most fields, can work most efficiently if assisted by two or three technicians. At the present time, there is only one technician to every two engineers. Shortage of technicians in industry causes losses when machines are shut down. In 63% of plants interviewed by an Electronic Industries Association group, failure of electronic components had caused down time, with costs varying from \$25 to \$300 for each out-of-service hour, reported K. I. Ede of Cleveland Institute of Electronics.

Comprehensive training programs at technical institute, community college and trade school level are necessary to turn the trend, panelists believed. Improvement of instruction by simplifying terminology and paying greater attention to teaching students how to use graphic aids and test equipment was suggested as a further help, as well as matching the levels of the courses to the qualifications of students. George Maedel of RCA Institutes pointed out that most electronic technicians today are the product of schools, and Joseph De France of New York Community College reported that improvements in school organization would be helpful. He especially recommended the 6-month semester instead of the full-year term, as help for the student who might find a semester's work too difficult and could take it over again, whereas few students would care to redo a full year's work. Mr. Gunter pointed out that whereas 1 technician for 10 engineers might be sufficient in research and development work, a design engineer might profitably use a technician to breadboard equipment, a draftsman, a tester and a technical writer. He also suggested that more attention be paid to the use of women technicians, since they form the greatest present source of untapped "manpower." END

EQUIPMENT REPORT

KNIGHT-KIT P-2 SWR METER and HEATH HO-10 MONITOR SCOPE

AN SWR POWER METER IS IDEAL FOR matching a CB antenna to a CB transmitter. The better the match, the more efficient the equipment. The Knight-Kit P-2 measures standing waves, has its meter calibrated in terms of relative power and is easy to use. The relative power scale uses the power output of the transmitter as a base, and measures the increase or decrease in output as adjustments are made.

Here's how it works (see schematic): Inside the pickup box is a section of coaxial cable, between J1 and J2. Two stiff wires, one on each side, are placed parallel to the cable's center conductor. These wires, with their associated capacitances, inductances and resistances, form a bridge circuit. The rf picked up by them is rectified by diodes D1 and D2 and brought out through a cable to the meter box.

S1 in the meter box selects the FORWARD or the REFLECTED position. The meter reads rectified radio energy, so no

power or batteries are required.

The 100- μ A meter gives full-scale deflection with plenty of reserve sensitivity, even with the low power levels of CB gear. It can be used on either 52- or 72-ohm cable by using the proper resistance for R1 and R2.

The P-2 will also detect power losses in a length of coax cable. Simply attach a dummy load to one end of the coax and the SWR/Power Meter pickup box between the other end and the transmitter. Then, with the transmitter on, adjust the sensitivity control to give a relative power reading of 10. (A simple nonreactive dummy load can be made from 150-ohm 2-watt carbon resistors—three in parallel for 52 ohms and two in parallel for 72 ohms. Check final resistance—resistors do vary.)

Now take out the pickup box from between the cable and transmitter and insert it between the cable and load. Any drop in the reading indicates a

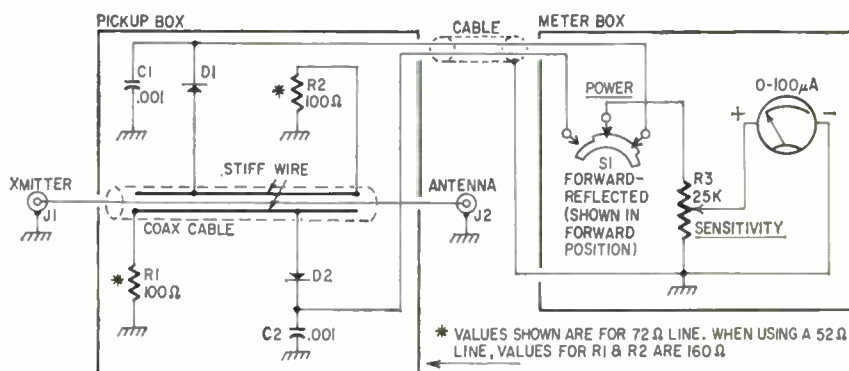

The circuit of this unit is rather simple.



The Knight-Kit model P-2 SWR/Power Meter.

SERVICE TECHNICIANS, ENGINEERS, TEST LABS SAY . . . THE POPULAR MIGHTY MITE IS

"The Best Tube Checker they ever used."

Here it is . . .

THE MIGHTY MITE

Designed for the present and far into the future. Tests all of your present tubes plus the new RCA Nuvisors and Novars, GE Compactrons and Sylvania 10 pin tubes.



*Finds 'em Fast!
Checks 'em All!*

A complete tube tester that is smaller than a portable typewriter yet outperforms testers costing hundreds of dollars. A real money maker for the serviceman and a trusty companion for engineers, maintenance men and experimenters.

Even though the Mighty Mite weighs less than 8 pounds, new circuitry by Sencore enables you to use a meter to check grid leakage as high as 100 megohms and gas conditions that cause as little as one half microamp of grid current to flow. Then too, it checks for emission at operating levels and shorts or leakage up to 120,000 ohms between all elements. This analytical "stethoscope" approach finds troublesome tubes even when large mutual conductance testers fail. And it does all this by merely setting four controls labeled A, B, C, & D.

Check these plus Sencore features: New, stick-proof D'Arsonval Meter will not burn out even with a shorted tube • Meter glows in dark for easy reading behind TV set.

- New large Speedy Set-Up Tube Chart in cover, cuts set-up time
- Rugged, all-steel carrying case and easy grip handle
- Smallest complete tester made, less than one foot square.
- The Mighty Mite will test every standard radio and TV tube that you encounter, nearly 2000 in all, including foreign, five star, auto radio tubes (without damage) plus the new GE Compactrons, RCA Nuvisors and Novars and Sylvania 10 pin tubes.

Mighty Mite also has larger, easy-to-read type in the set-up booklet to insure faster testing. Why don't you join the thousands of servicemen, engineers, and technicians who now own a Mighty Mite tube tester? Tube substitution is becoming impossible and costly with nearly 2000 tubes in use today. Ask your authorized Sencore Distributor for the New Improved Mighty Mite. Size: 10 1/4" x 9 1/4" x 3 1/2". Wt. 8 lbs.

MODEL TC114

Dealer Net **\$74.50**

*Sencore Sam says . . .
"They all agree . . . the Mighty Mite
is the real answer for the man on the go."*



SENCORE ADDISON, ILLINOIS

loss in the cable—if the meter now reads 5, cable loss is 3 db, indicating that half the transmitter output is lost in the cable. While this is excessive, even the best cable will introduce some losses. These range from 0.93db in 100 feet of RG-8/U to 1.8 db in 100 feet of RG-59/U.

When checking swr, remember that the swr reading can be interpreted as percent of reflected power—the power not delivered to the antenna. For example, if the swr is 2, 11% of the power leaving the transmitter is reflected, and the antenna radiates only 89% of the energy produced by the transmitter.

An swr reading of more than 1 on the line connecting your transmitter to its antenna is caused by a mismatch between the antenna and the transmission line. This results in less than maximum possible power being radiated, which shortens the effective communications range of your equipment. With the P-2 SWR/Power Meter you can adjust your antenna to make it operate at top efficiency and get the maximum possible range from your equipment.

The HO-10

A HANDY INSTRUMENT FOR THE TECHNICIAN or CB or amateur gear operator, this monitor gives a minute-by-minute picture of the rf signal being transmitted and reveals such things as overmodulation, no modulation, nonlinear modulation, etc.

The schematic shows the circuit. A portion of the rf signal to be monitored is picked off the transmitter's antenna feed line and fed to vertical deflection plates of the CRT. A receiver can be checked by taking off a portion of the signal voltage in the i.f. circuit. This signal is applied to the monitor's vertical input, then through an amplifier and on to the CRT vertical deflection plates.

The single-stage horizontal amplifier (V3-c) is one third of a triple-triode compactron. It has a frequency response of ± 3 db from 10 cycles to 500 kc and a sensitivity of 500 mv per inch.

The sweep generator requires two triode sections (V3-a and V3-b) hooked up as a free-running multivibrator sawtooth generator. Sweep frequency can be adjusted between 15 and 200 cycles with the front-panel sweep-frequency control.

The oscillator circuit uses a twin-pentode compactron (V4), each pentode section operating as a phase-shift oscillator. One unit oscillates at 1,000 cycles, the other at 1,700. The pots in the cathodes of these pentodes will vary the frequency slightly, but their primary purpose is to control the output amplitude of their oscillators. These oscillators are used together for test-modulating SSB transmitters.

The clamper circuit automatically deflects the no-signal spot off the screen to keep it from burning the phosphor.

The Heath HO-10 monitor scope is a handy little instrument.

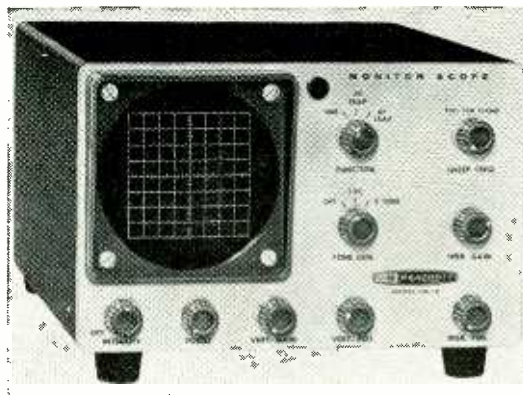

This is needed during a setup for a trapezoid display of a transmitted signal as the trace comes down into a single spot when there is no signal. This circuit, using triode V1-b and diode V1-c, is inserted into the circuit whenever the function switch is in either trap position and the CLAMP DISABLE switch on the sweep-frequency control is pulled out (switch open).

The power supply is isolated from

the ac line by a power transformer. The 1V2 half-wave rectifier delivers a negative 1,600 volts for the CRT. A full-wave voltage doubler produces 270 and 580 volts—four are used.

The HO-10 will cover 160 through 6 meters. It can be used on 2 meters but some distortion will result. Any transmitter between 5 and 1,000 watts can be monitored. END

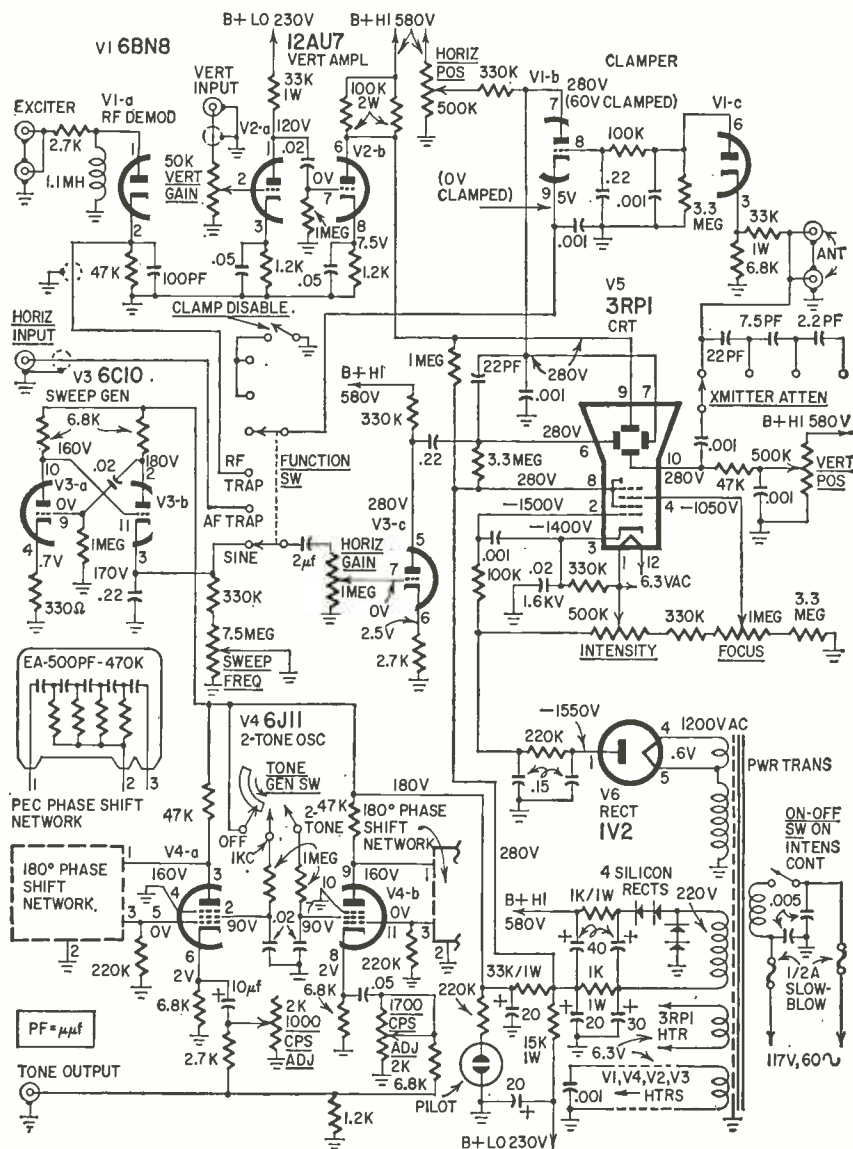

Circuit of the HO-10.

RAD-TEL

You Get MORE For Your Money!

RAD-TEL'S QUALITY BRAND NEW TUBES

FOR TV, RADIO AND HI-FI
1-YEAR GUARANTEE

UP TO **75% OFF**

1-DAY SERVICE • Over 500 Types in Stock



SERVICEMEN:
RAD-TEL HAS THE LATEST TUBE TYPES.

THE SIGN OF RAD-TEL'S RELIABILITY FOR OVER 15 YEARS

*Manufacturers Suggested List Price

FREE! Send For New Tube & Parts Catalog
Send For Trouble Shooting Guide



Be your own TELEVISION REPAIRMAN

The Original NOW YOU CAN
FIX YOUR OWN TV SET BOOK

You can fix your own TV if you have TV Fixit Book . . . because 80% of troubles are caused by tubes. This book explains, illustrates trouble and what tubes cause this trouble. Pinpoints in over 3000 layouts by model number, position and type tube causing trouble.

No. 170 \$1.00



CHEATER CORD

Easy to work on set while panel is off.

6 ft., No. 154 29¢ ea. Lots of 3—25¢ ea.



RAD-TEL TUBE CO. TV, RADIO AND HI-FI

DEPT. RE-2 55 CHAMBERS STREET, NEWARK 5, NEW JERSEY

TERMS: 25% deposit must accompany all orders, balance C.O.D. Orders under \$5. add \$1 handling charge plus postage. Orders over \$5: plus postage. Approx. 8 tubes per lb. Subject to prior sale. No C.O.D.'s outside continental U.S.A.

EACH TUBE ATTRACTIVELY BOXED & BRANDED RAD-TEL

Qty.	Type	Price	Qty.	Type	Price	Qty.	Type	Price	Qty.	Type	Price
—	0Z4	.79	—	6AU8	.87	—	6K6	.63	—	12CU5	.58
—	1AX2	.62	—	6AV6	.41	—	6S4	.52	—	12CU6	1.06
—	1B3	.79	—	6AW8	.90	—	6SA7GT	.99	—	12CX6	.54
—	1DN5	.55	—	6AX4	.66	—	6SH7	1.02	—	12D4	.69
—	1G3	.79	—	6AX5	.74	—	6SJ7	.88	—	12DE8	.83
—	1J3	.79	—	6BA5	.50	—	6SK7GT	.95	—	12DL8	.88
—	1K3	.79	—	6BC5	.61	—	6SL7GT	.84	—	12DQ6	1.04
—	1R5	.77	—	6BC8	1.04	—	6SN7	.65	—	12DS7	.84
—	1S5	.75	—	6BE6	.55	—	6SQ7GT	.94	—	12DT5	.76
—	1T4	.72	—	6BF5	.90	—	6T4	.99	—	12DT7	.79
—	1U5	.65	—	6BF6	.44	—	6T8	.85	—	12DT8	.78
—	1X2B	.82	—	6BG6	1.70	—	6U8	.83	—	12DW8	.89
—	2AF4	.96	—	6BH8	.98	—	6V6GT	.54	—	12DZ6	.62
—	3AL5	.46	—	6BJ6	.65	—	6W4	.61	—	12ED5	.62
—	3AU6	.54	—	6BJ7	.79	—	6W6	.71	—	12EG6	.62
—	3AV6	.42	—	6BK7	.85	—	6X4	.41	—	12EK6	.62
—	3BC5	.63	—	6BL7	1.09	—	6X8	.80	—	12ELG	.50
—	3BN6	.75	—	6BN6	.74	—	7A8	.68	—	12EZ6	.57
—	3BU8	.78	—	6BQ6	1.12	—	7AU7	.65	—	12F8	.66
—	3BY6	.58	—	6BQ7	1.00	—	7EY6	.75	—	12FA6	.79
—	3BZ6	.56	—	6BU8	.70	—	7Y4	.69	—	12FM6	.50
—	3CB6	.56	—	6BX7	1.11	—	8AU8	.90	—	12FR8	.97
—	3CS6	.58	—	6BZ6	.55	—	8AW8	.93	—	12FX8	.90
—	3DG4	.85	—	6BZ7	1.03	—	8BQ5	.60	—	12GC6	1.06
—	3DK6	.60	—	6C4	.45	—	8CG7	.63	—	12J8	.84
—	3DT6	.54	—	6CB6	.55	—	8CM7	.70	—	12K5	.75
—	3GK5	.99	—	6CD6	1.51	—	8CN7	.97	—	12L6	.73
—	3Q4	.63	—	6CG7	.61	—	8CS7	.74	—	12SF7	.69
—	3S4	.75	—	6CG8	.80	—	8EB8	.94	—	12SK7GT	.95
—	3V4	.63	—	6CL8	.79	—	8FQ7	.56	—	12SL7	.80
—	4BQ7	1.01	—	6CM7	.69	—	9CL8	.79	—	12SN7	.67
—	4CS6	.61	—	6CN7	.70	—	11CY7	.75	—	12SQ7GT	.91
—	4DT6	.55	—	6CQ8	.92	—	12A4	.60	—	12U7	.62
—	4GM6	.60	—	6CR6	.60	—	12AB5	.60	—	12V6	.63
—	5AM8	.79	—	6CS6	.57	—	12AC6	.55	—	12W6	.71
—	5AN8	.90	—	6CS7	.69	—	12AD6	.57	—	12X4	.47

RAD-TEL TUBE CO. NOT AFFILIATED WITH ANY OTHER MAIL ORDER TUBE COMPANY

—	5AQ5	.54	—	6CU5	.58	—	12AE6	.50	—	17AX4	.67
—	5AT8	.83	—	6CU6	1.08	—	12AE7	.94	—	17DQ6	1.06
—	5BK7	.86	—	6CY5	.70	—	12AF3	.73	—	18FW6	.49
—	5BQ7	1.01	—	6CY7	.71	—	12AF6	.67	—	18FX6	.53
—	5BR8	.83	—	6DA4	.68	—	12AJ6	.62	—	18FY6	.50
—	5CG8	.81	—	6DE6	.61	—	12AL5	.47	—	19AU4	.87
—	5CL8	.76	—	6DG6	.62	—	12AL8	.95	—	19BG6	1.39
—	5CQ8	.84	—	6DJ8	1.21	—	12AQ5	.60	—	19EAB	.79
—	5EA8	.80	—	6DK6	.59	—	12AT6	.50	—	19T8	.85
—	5EU8	.80	—	6DN6	1.55	—	12AT7	.76	—	21EX6	1.49
—	5J6	.72	—	6DQ6	1.10	—	12AU6	.51	—	25AX4	.70
—	5T8	.86	—	6DT5	.81	—	12AU7	.61	—	25C5	.53
—	5U4	.60	—	6DT6	.53	—	12AV6	.41	—	25CA5	.59
—	5U8	.84	—	6DT8	.94	—	12AV7	.82	—	25CD6	1.52
—	5V6	.56	—	6EA8	.79	—	12AX4	.67	—	25CU6	1.11
—	5X8	.82	—	6EB5	.73	—	12AX7	.63	—	25DN6	1.42
—	5Y3	.46	—	6EB8	.94	—	12AY7	1.44	—	25EH5	.55
—	6AB4	.46	—	6EM5	.77	—	12AZ7	.86	—	25L6	.57
—	6AC7	.96	—	6EM7	.82	—	12B4	.68	—	25W4	.68
—	6AF4	1.01	—	6EU8	.79	—	12BD6	.50	—	32ET5	.55
—	6AG5	.70	—	6EV5	.75	—	12BE6	.53	—	35C5	.51
—	6AH4	.81	—	6EW6	.57	—	12BF6	.60	—	35L6	.60
—	6AH6	1.10	—	6EY6	.75	—	12BH7	.77	—	35W4	.42
—	6AK5	.95	—	6FG7	.69	—	12BK5	1.00	—	35Z5	.60
—	6AL5	.47	—	6FV8	.79	—	12BL6	.56	—	36AM3	.36
—	6AM8	.78	—	6GH8	.80	—	12BQ6	1.16	—	50B5	.69
—	6AQ5	.53	—	6GK5	.61	—	12BR7	.74	—	50C5	.53
—	6AS5	.60	—	6GK6	.79	—	12BV7	.76	—	50EH5	.55
—	6AT6	.49	—	6GN8	.94	—	12BY7	.77	—	50L6	.61
—	6AT8	.86	—	6H6	.58	—	12BZ7	.86	—	70L7	.97
—	6AU4	.85	—	6J5GT	.51	—	12CN5	.56	—	117Z3	.85
—	6AU6	.52	—	6J6	.71	—	12CR6	.67	—	807	.75

ORDER FORM MAIL TODAY

RAD-TEL Tube Co.

Dept. RE-2

55 Chambers Street

Newark 5, New Jersey

ENCLOSED IS \$

Total Tubes \$

Total Part(s) \$

Postage \$

Grand Total \$

SEND: Book(s) Be Your Own TV Repairman @ \$1.00 ea. #170

Cheater Cord 29¢ ea. Lots of 3 - 25¢ ea. #154

Orders under \$5.00 - Add \$1.00 handling charge - plus postage.

Send FREE Tube and Parts Catalog

Send FREE Trouble Shooting Guide

NAME _____

ADDRESS _____

CITY _____ ZONE _____ STATE _____

Little Dipper

Build a sensitive hand-sized dip meter



By I. QUEEN
EDITORIAL ASSOCIATE

This dipper, simple and inexpensive to build, covers 3.8 to 100 mc with four coils. It uses an inexpensive transistor energized by only 3 volts. Power drain is insignificant. A single calibration suffices for all bands. Measuring only 4 x 2 1/4 x 2 1/4 inches, the instrument weighs less than 11 ounces. Most important, its dip sensitivity is very high.

Many transistorized dipmeters use a capacitor between collector and emitter for oscillator feedback. The method is simple, but it favors the higher frequencies. In this dipmeter (Fig. 1) capacitor C1 provides feedback for the two higher bands. The two lower bands use tapped coils in a Hartley circuit. It is true that a larger C1 is often used to provide adequate feedback over the entire range, but this has two disadvantages: It degrades the frequency ratio (maximum to minimum on each band) and drives the oscillator too much at high frequencies, making the dipmeter less sensitive. This dipmeter has a frequency ratio better than 2 1/2 to 1 on each band.

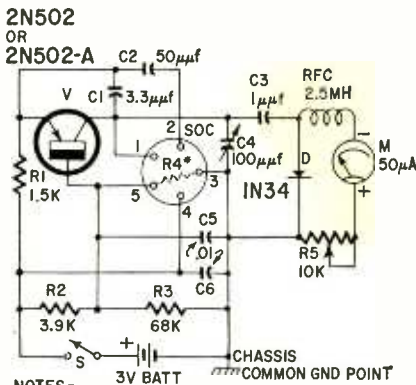

NOTES—
R4 IS INSIDE COIL FORM (SEE TEXT)
SOC PIN 4 IS A TIE POINT ONLY

The instrument uses miniature plug-in coils. To keep leads as short as possible, mount the coil socket so that pin 1 touches the "hot" terminal of C4. Keep transistor leads short too.

Mount the transistor socket on a small strip of perforated board. Then connect C1 with very short leads. Wind all coils so the collector end (which goes to pin 1 of the socket) is at the top of the coil.

Most experimenters have had experience with the miniature Amphenol polystyrene coil forms. If you have some, they are excellent for L1 and L2. Note that these are tapped as shown in Fig. 2. Winding information is given in the table. Unfortunately, these handy forms are no longer available, but you can make an excellent substitute. Combine a length of 3/4-inch polystyrene tubing with a miniature bakelite five-pin plug (Amphenol 41-MPM5L or equivalent). This plug comes with a metal shield, which is not needed. Use the tubing in place of the shield.

[E. F. Johnson Poly Plug 3/4-inch plug-in coil forms are listed in the Allied and possibly other catalogs. These are 5- and 6-pin units.—Editor]

- R1—1,500 ohms
- R2—3,900 ohms
- R3—68,000 ohms
- R4—see table
- R5—pot, 10,000 ohms, 1/2-inch diameter
- All fixed resistors 1/2-watt 10%
- C1—3.3 µf, ceramic
- C2—50 µf, ceramic
- C3—1 µf, ceramic
- C4—100 µf, variable (Hammarlund MACP-100 B or equivalent)
- C5, C6—.01 µf, ceramic
- BATT—3 volts (2 penlight cells in series)
- D—1N34 diode
- L1, L2, L3, L4—see table
- M—50 µa, 1 1/2 inches square
- RFC—2.5 mh
- S—spst miniature toggle switch
- SOC—5-pin coil socket
- V—2N502 or 2N502-A
- Case—4 x 2 1/4 x 2 1/4 inches
- Transistor socket
- Plug-in coils
- Miscellaneous hardware

COIL-WINDING TABLE

	L1	L2	L3	L4
Frequency	4-10	8-20	16-40	40-100
Wire size	26	26	22	22
Total turns	29	11	9	2 1/2
Tapped section	2	1	—	—
Diameter*	3/4"	3/4"	1/2"	1/2"
R4	none	none	33K	10K

*see text

Because of the higher frequencies, L3 and L4 are wound on 1/2-inch poly forms. These are placed inside the outer 3/4-inch tubing. These coils also require a built-in bias resistor R4.

Calibrating the coils

I use only one basic calibration for all coils. This runs from 4-10 mc. L2 is wound to cover exactly twice this range. L3 covers 4 times and L4 10 times this basic range. Wind L2 first and base the calibration on this coil. Then wind the others, starting with a few more turns than called for in the table, removing a turn at a time until the calibration is matched. L1 may be off slightly at the high end of the dial, due to its large distributed capacitance. All bands may be calibrated by listening for the dipmeter signal on a short-wave receiver.

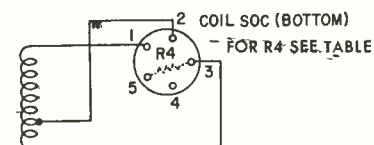

DIAGRAM FOR L1 & L2 (L3 & L4 ARE UNTAPPED & CONNECTED TO PINS 1 & 3)

Fig. 2—Coils L1 and L2 are set up in this fashion.

Free SEND TODAY FOR
YOUR MONEY-SAVING
464-PAGE



ALLIED
1963 CATALOG

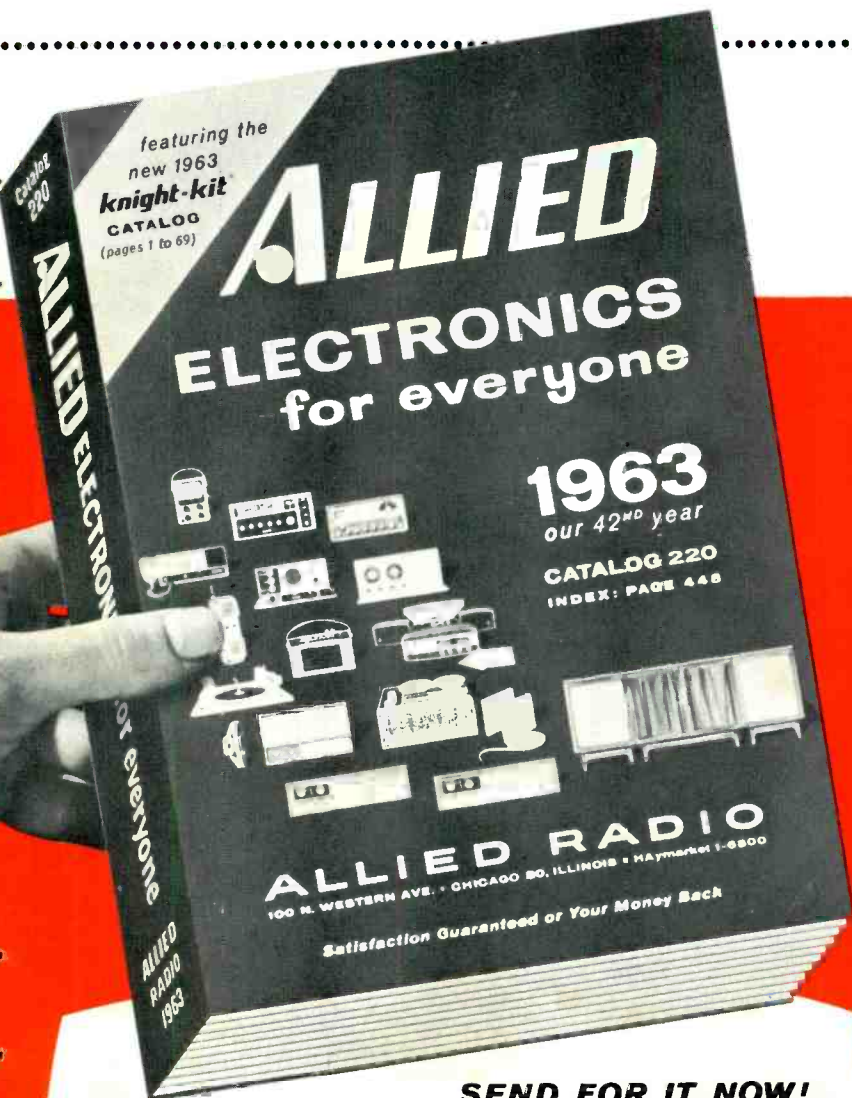

SEND FOR IT NOW!

WORLD'S LARGEST ELECTRONICS CATALOG
BIGGEST SELECTION • BIGGEST SAVINGS!

satisfaction guaranteed or your money back

NO MONEY DOWN: NOW! MORE BUYING POWER WITH
YOUR ALLIED CREDIT FUND PLAN

**SEE
OTHER
SIDE**

For your **FREE** 1963
ALLIED Catalog, fill in
card, detach and mail.
(Please give second card
to an interested friend.)

**SEND
CARD
TODAY**



Name
PLEASE PRINT

Address

City

State

Zone

12-1-B



YOUR **Free**
ALLIED
1963 CATALOG

Name
PLEASE PRINT

Address

City

State

Zone

12-1-B



YOUR **Free**
ALLIED
1963 CATALOG



Free SEND CARD TODAY FOR YOUR 464-PAGE

ALLIED

1963 CATALOG

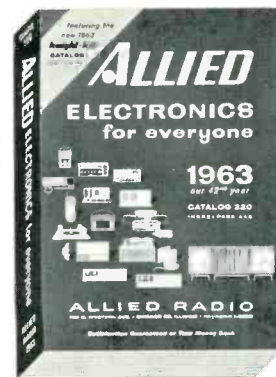

WORLD'S LARGEST • BIGGEST SELECTION • BIGGEST SAVINGS

TO:
ALLIED RADIO
100 N. WESTERN AVE.
CHICAGO 80, ILL.

PLACE
STAMP
HERE

NEW

1963 knight-kits®

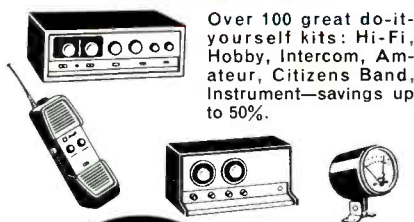

Over 100 great do-it-yourself kits: Hi-Fi, Hobby, Intercom, Amateur, Citizens Band, Instrument—savings up to 50%.

NEW

Stereo Hi-Fi

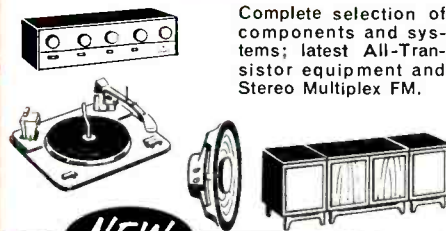

Complete selection of components and systems; latest All-Transistor equipment and Stereo Multiplex FM.

NEW

Tape Recorders



Complete recorders, tape decks, recording and pre-recorded tapes at big savings.

NEW

Citizens Band Radios



Latest 2-way radio—no exam required—complete selection of top-value CB equipment, including Walkie-Talkies.

NEW

Transistor, FM-AM Radios



Best buys in all types of compact transistor radios, including quality FM-AM portables.

NEW

Phonographs & Records



Big values in phonographs; latest stereo portables; famous-brand records at amazing discounts.

NEW

Ham Station Equipment



Largest selection of receivers, transmitters, antennas—everything in Ham station gear.

NEW

Test Equipment



Save on every type of instrument for home or professional use—all leading makes available.

TO:
ALLIED RADIO
100 N. WESTERN AVE.
CHICAGO 80, ILL.

PLACE
STAMP
HERE

PLUS • PA Systems & Intercoms • Top values in Power Tools, Soldering Guns, Hardware • Biggest selection of TV Tubes, Antennas; Parts, Tubes, Transistors, Books

satisfaction guaranteed or your money back

NO MONEY DOWN: Now! More Buying Power with Your Allied Credit Fund Plan!



Free MAIL CARD TODAY FOR YOUR 1963 ALLIED CATALOG

AND GIVE THIS CARD TO A FRIEND

Note that dipmeters are not recommended for *precision* frequency measurements. Don't try to tune TV traps or precise networks with a dipmeter. The better commercial dipmeters specify 2% accuracy, and the ordinary ones don't specify at all!

The photo shows that C4 is

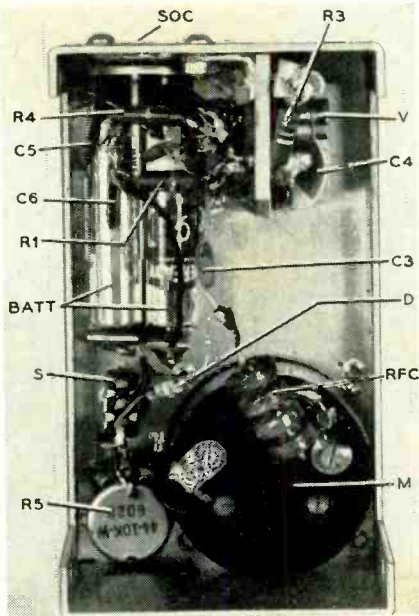

The case may be small, but it isn't overly cramped.

mounted off center. This permits its knob to extend beyond the box for thumb-tuning. If you hold the dipmeter in your left hand, the thumb of this hand can press against the knob and tune it.

To protect completed coils, cover them with polystyrene cement.

If you set the meter to near full scale at the high end of L1 or L2, you need not reset thereafter. The deflection will tend to be highest near the high-frequency end of each band, but you need not operate near full scale for maximum sensitivity. Actually, sensitivity will probably be greatest at the low end of a band, in spite of the reduced meter reading. Near 100 mc (L4) the reading may fall somewhat, depending upon the efficiency of the particular transistor you are using. In fact, you may use this dipmeter to check the condition of the transistor.

The instrument's high sensitivity results from having optimum bias on each band. The voltage applied to the base is kept just low enough for reliable oscillation. The actual dip varies with the Q of the test circuit, and also with the capacitance to which C4 is tuned. At a distance of about 1 inch from the external coil, you may expect dips of about half-scale. A perceptible dip will often occur at a distance of 1 1/2 inches or more.

END

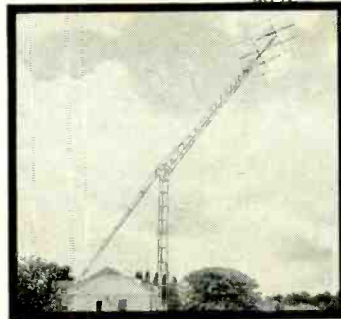
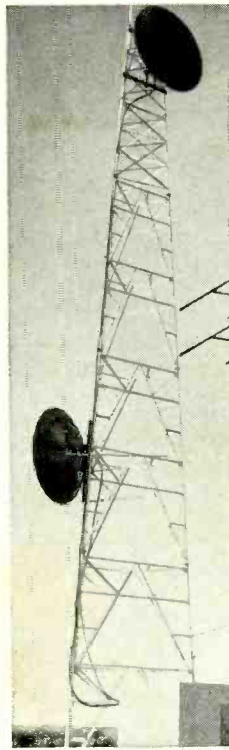

The most Famous Name in TOWERS of ALL KINDS!

Here are the advantages you get when you insist on ROHN TOWERS

LARGEST FULL RANGE OF TOWERS—you can get anything from home TV and amateur radio towers to heavy-duty communication and micro-wave towers. Included are 170 foot self-supporting towers, 1,000 foot guyed towers, and "fold-over" towers. Regardless of your needs, ROHN can supply it.

UNQUESTIONED LEADERSHIP IN DESIGN AND MANUFACTURE—you get the latest in advanced tower engineering. All communication towers are engineered to EIA specifications, and are proved by thousands of installations. No other manufacturer can surpass the quality and fine reputation of ROHN.

QUALITY MATERIALS AND WORKMANSHIP—Only highest quality steel is used which fully meets the specifications for the job. ROHN towers are hot-dipped galvanized **after** fabrication—a feature ROHN pioneered!

SERVICE WHEREVER YOU WANT IT—ROHN representatives are world-wide. Complete erection service for communication systems, broadcasting, micro-wave, and other needs is available; also competent engineering service to help you.

Settle for the BEST in TOWERS—ROHN—today the world's largest, exclusive manufacturer of towers of all kinds!

For your needs, contact your local ROHN salesman, distributor or dealer; or write direct for information.

SEND THE HANDY COUPON INDICATING YOUR NEEDS

ROHN
Manufacturing
Company
BOX 2000
PEORIA, ILLINOIS

ROHN Manufacturing Company
Box 2000
Peoria, Illinois

Send me complete literature on the following ROHN Products:

- | | |
|-----------------------------------------------|----------------------------------------------------|
| <input type="checkbox"/> Home TV Towers | <input type="checkbox"/> Amateur Towers |
| <input type="checkbox"/> Communication Towers | <input type="checkbox"/> AM-FM Broadcasting Towers |
| <input type="checkbox"/> Micro-Wave Towers | <input type="checkbox"/> Government |

Name _____

Firm _____

Address _____

City _____ State _____

Want to get ahead in SERVICING?

The G/L Technicians' Book Club can help you.

(See advertisement on page 108)

Gernsback Library, Inc.

154 West 14th St.

New York 11, N. Y.

AUDIO unlimited

Specializes in SAVING YOU MONEY

- ✓ FACTORY FRESH COMPONENTS
- ✓ LOWEST POSSIBLE QUOTATIONS
- ✓ FAST DELIVERY

We are FRANCHISED for most HI-FI lines. Orders SHIPPED PROMPTLY from our large stock. RECORDING TAPE at LOWEST PRICES. FREE STEREO CATALOG

715-R 2nd Ave., near 38th, New York 16, N. Y.

Visit Our Showroom

COMPONENTS, TAPE RECORDERS

Write for our low quotes on your choice of components. Save more on "pckges". All factory sealed. Send for "Monthly Specials" bulletin.

	3-11	12-23	24+
1200' 7" acetate	\$1.09	\$1.05	\$.98
1200' 7" mylar	1.19	1.15	1.09
1800' 7" acetate	1.59	1.50	1.39
1800' 7" mylar	1.88	1.84	1.78
2400' 7" mylar	2.59	2.52	2.39
2400' 7" tensitized mylar	2.89	2.84	2.78

Can Be Assorted. Add 15c Postage Per Reel. 10c for 24 lots

125-RD East 88 St., New York 28, N. Y.
CARETON Studios

Busy People



keep in touch . . .



WITH **UTICA**
CB TRANSCEIVERS

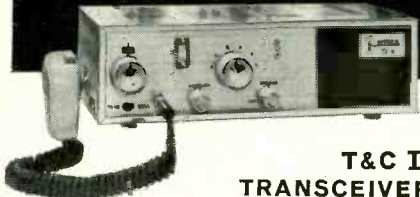

T&C II TRANSCEIVER

New dual conversion 6 channel crystal controlled transceiver with tunable receiver for all CB channels. S meter and signal strength output indicator, external crystal socket, auxiliary speaker terminal and universal power supply. Deluxe chrome cabinet. List Price **199.95**



TOWN & COUNTRY MC-27 TRANSCEIVER

Dual conversion 6 channel crystal controlled. Exceptional sensitivity and selectivity. Double Gated Noise Suppression circuit, AVC with improved squelch circuit. Universal power supply. Deluxe chrome cabinet. List Price **179.50**

CB ANTENNAS

GIZMOTCHY 2 in 1
Vertical-Horizontal Beam Antenna for hi-efficiency and greater distance base station performance. List Price **.55.95**

BUDDY WHIP
96 inch fibre glass mobile antenna. Can be adjusted to any position from driver's seat. List Price. **24.50**

UTICA

COMMUNICATIONS CORP.,
Dept. RE-2
2917 W. IRVING PARK RD.,
CHICAGO 18, ILLINOIS

Sold thru leading Parts Distributors

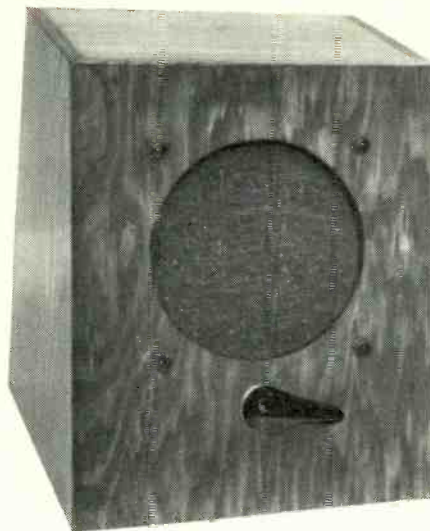

The completed master unit. The remote is in a matching cabinet, but uses a different type switch.

Make your own transformerless Intercom

3-transistor unit draws power only when in use

By **ALEX M. SCHOTZ**

THIS intercom is designed to keep initial and operating costs low. It draws power only when in operation. With a 12-volt supply, it uses about 75 ma and the output power is in excess of 100 mw.

The amplifier is housed in the master station's enclosure. The slave unit has the same speaker and enclosure, but no amplifier (see circuit).

Switching is set up so that the master station is normally in the receive position. When the slave switch is closed, it applies power to the amplifier through the transmission line and common ground. The slave speaker then acts as a microphone through the master's switch and feeds the amplifier input. This signal is fed through the input blocking capacitor to the base of V1, which is operated as a common-emitter amplifier. Thus, reasonable

power and voltage gain are provided.

Further amplification is needed so V1 is coupled through a capacitor to V2, which is also operated as a common-emitter amplifier. V2's output is directly coupled to V3. It forms a common-collector stage and serves as an emitter follower to match V2's output impedance to the speaker voice coil.

When the switch at the master unit is operated, it connects the batteries and also connects its speaker to the amplifier input. It then acts as a microphone and the amplifier output is connected through the transmission line to the speaker in the slave unit.

Volume can be controlled either by adding a potentiometer in the amplifier input or decreasing the voltage from the power supply.

When building the amplifier, no shielding or special precautions are necessary, as all circuits are fairly low impedance, although you may get bet-

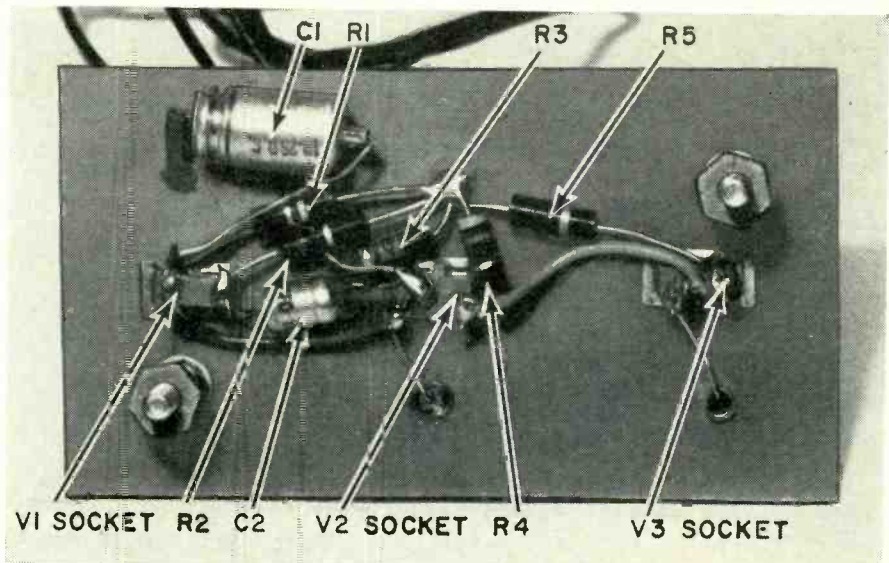

Parts layout under the amplifier chassis.

you have this now...

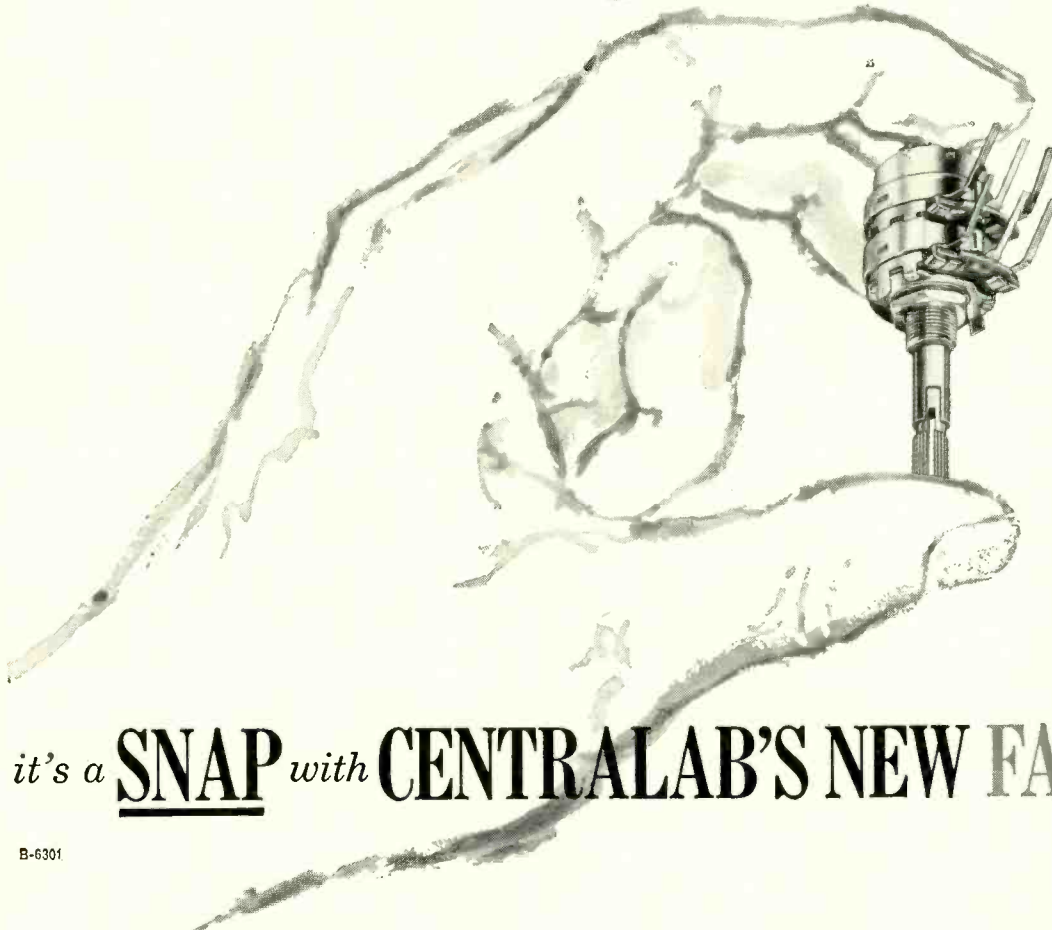
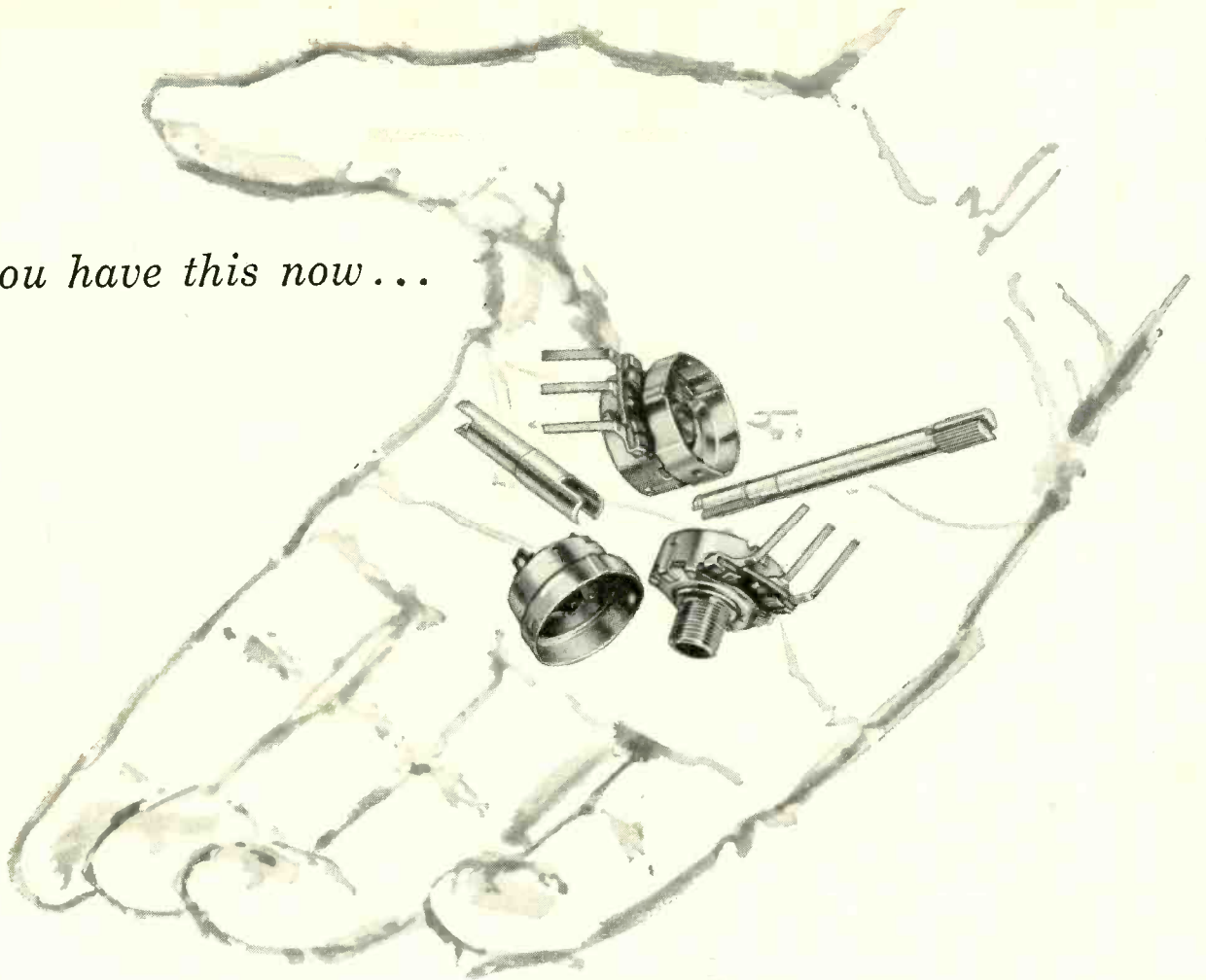

you have this

10

**SECONDS
LATER!**

it's a **SNAP** *with* **CENTRALAB'S NEW FASTATCH® II**

B-6301

(see next page)

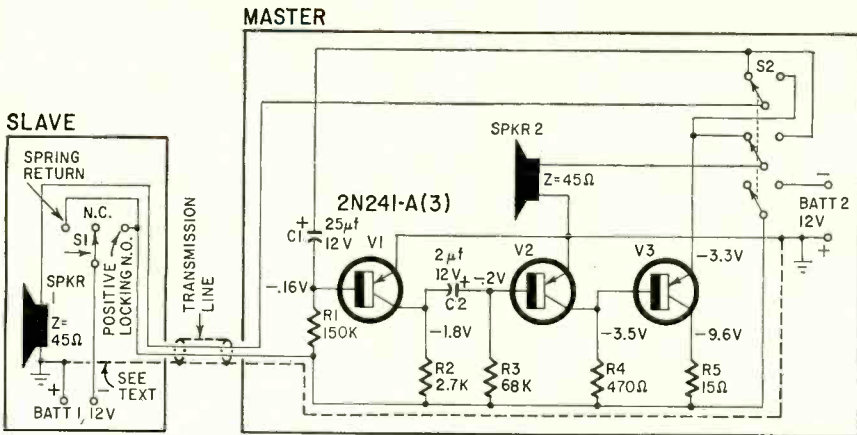

Circuit of the simple intercom system.

- R1—150,000 ohms
- R2—2,700 ohms
- R3—68,000 ohms
- R4—470 ohms
- R5—15 ohms
- All resistors 1/2-watt 10%
- C1—25 μ f, 12 volts, miniature electrolytic
- C2—2 μ f, 12 volts, miniature electrolytic
- BATT 1, BATT 2—12 volts
- S1—single pole, 3 positions: one spring-return position, one locking position, one center-off position (Centralab lever type 1467 or equivalent, use only one section)
- S2—double pole, 3 positions, rotary, spring return (Centralab 1472 or equivalent)
- SPKR 1, SPKR 2—45-ohm voice coil, size to suit
- V1, V2, V3—2N241-A
- Transistor sockets (3)
- Chassis and case to suit
- Miscellaneous hardware

ter results if the leads are kept short without too many crossovers.

There are two transmission wires and a common ground. If an adequate ground is not available, a third wire becomes necessary.

The slave unit has both a spring return and a locking position so, when necessary, the unit can be left on in the locked position—for baby sitting, for example.

The cabinets for these units were

hand-made, and the construction is simple for anyone handy with woodworking. Similar finished cabinets are readily available and can be purchased by those who do not wish to make their own. END

Unusual Bench Aids

By JOHN A. COMSTOCK

HERE ARE FOUR LITTLE AIDS THAT YOU'LL FIND EXTREMELY HANDY ON YOUR BENCH. THEY'RE INEXPENSIVE AND—MOST IMPORTANT—WORTH OWNING AND USING.



First is a radio-chassis vacuum cleaner. It's simply a flashlight type vacuum cleaner you can use for clearing dust from the chassis of radios, TV's and hi-fi gear. It gets into places where you could never use a regular vacuum cleaner.

Next is a nail-clipper wire stripper. As is, that pocket nail clipper can be used to strip insulation in a pinch. You can make it even easier to use if you file a little notch in one of the cutting edges. It will protect the wire and make stripping even easier.

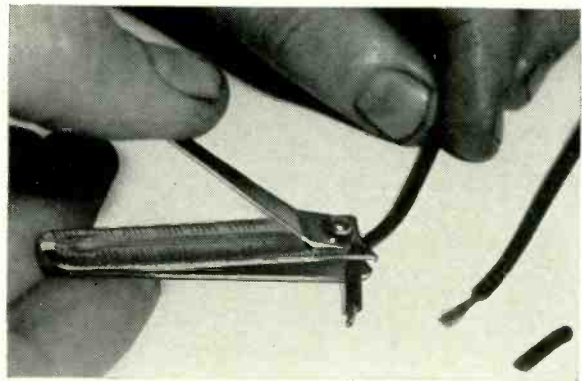

The last little item comes from the Boeing Airplane Co. It's a standard metal clip lined with felt. The felt is dunked in water and the clamp attached to the lead between the soldered joint and the component. Heat traveling along the lead is dissipated by evaporation of water from the felt. END

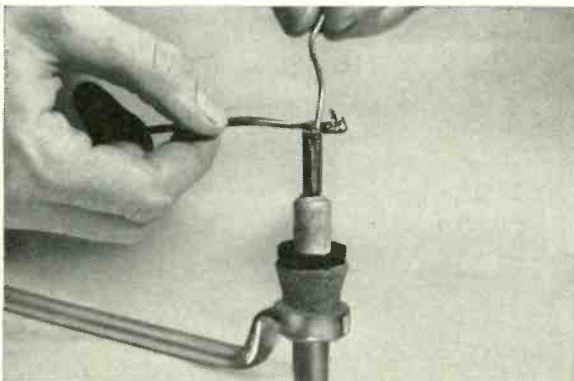

This soldering pencil stand is another handy item. It holds the pencil pointed straight up, letting you use both hands to hold the work. What is the stand? It's simply one end of a box wrench. The other end is clamped in a vise.

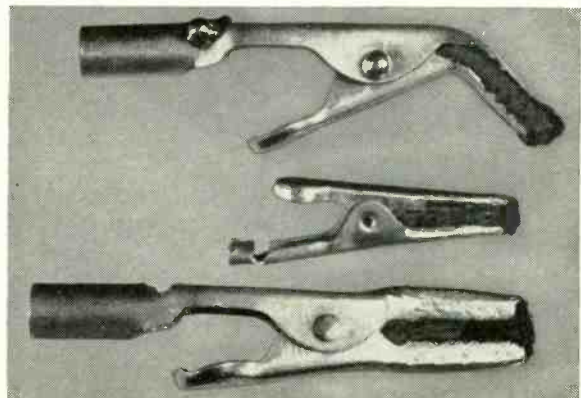

Now in stock at your distributor

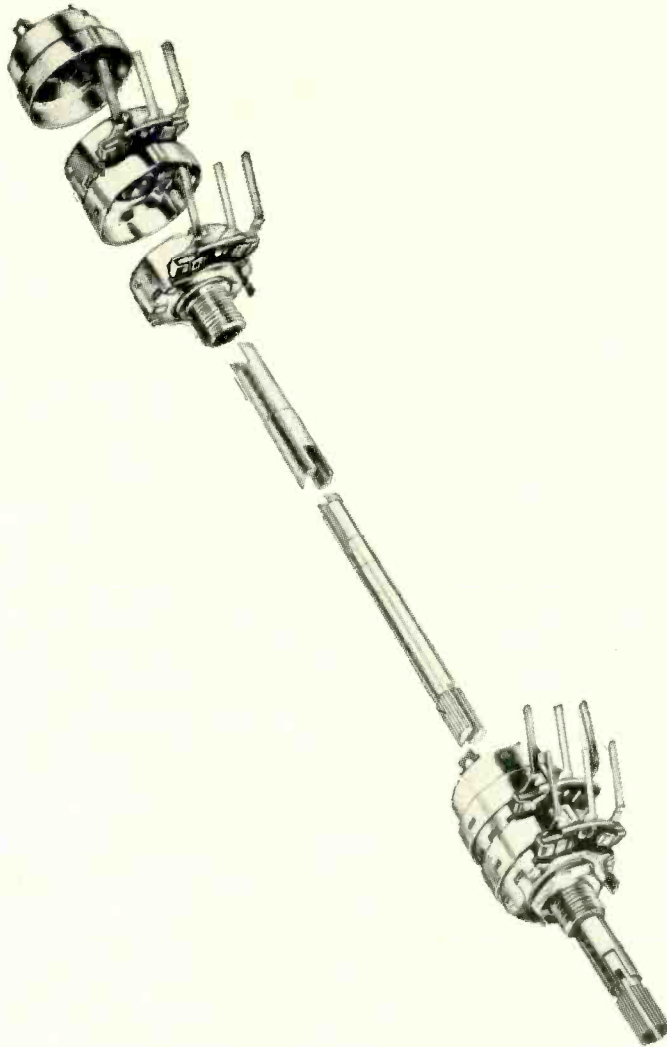

THE NEW FASTATCH® II

**FROM CENTRALAB
GIVES YOU** *complete
instant exact replacement control
coverage for dual concentric,
single, and matched twin controls.*

Fastatch II gives you convenient and simple control assembly. Any control can be permanently assembled in seconds—no shaft cutting—no complicated alignment—no twisting. Just snap together and install. Your Fastatch II product will be identical to the manufacturer's original control. Check these FASTATCH II features:

- No shaft cutting . . . Exact replacement shafts are available for every application regardless of length or termination.
- Shaft won't loosen or pull out—permanent locking construction.
- Universal terminals replace all three types of printed circuit, wire-wrap and hole type terminals.
- No backlash on duals and twins.



NEW FASTATCH® II FRK-100 KIT

Everything needed to assemble an infinite variety of controls in seconds.

- 36 assorted front and rear controls in the 27 most popular resistance values
- 40 universal shafts
- 8 switches
- Current cross-reference guide
- Heavy-gauge steel cabinet.

B6308

Centralab
ELECTRONICS

THE ELECTRONICS DIVISION OF GLOBE-UNION INC,
922A East Keefe Avenue • Milwaukee 1, Wisconsin
In Canada: Centralab Canada Ltd., P. O. Box 400, Ajax, Ontario

Solid Sync for Your Scope

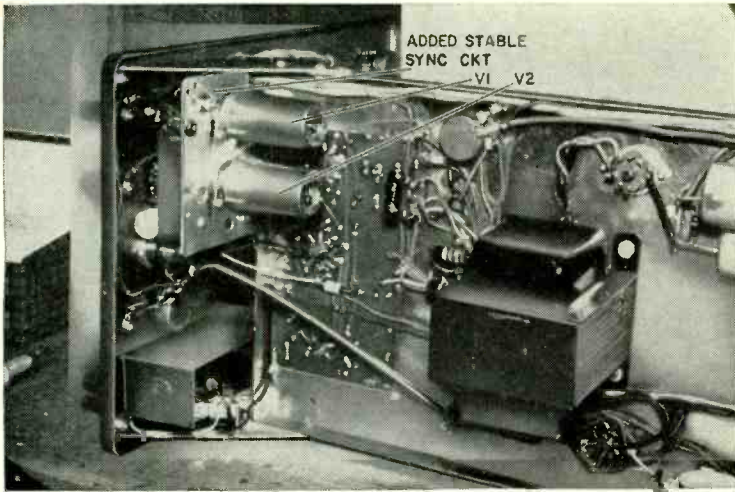

2-tube circuit you can add in an hour or two

Did you ever wonder what you could do to make your scope trace stand still like those on laboratory scopes? If so, this circuit is the answer. It can be added simply and inexpensively to almost any oscilloscope. Once it is wired in, your scope will present rock-solid pictures of the input signal, even when the vertical deflection is so small as to be almost invisible. And it will not lose sync with every small signal-frequency or line-voltage change.

Both sections of V1 (Fig. 1) combine to form a wide-band high-gain amplifier which boosts the low-level sync signal enough to allow the circuit to operate no matter what the input level. In addition, the second stage, V1-b, limits on high-level inputs to avoid overdriving V2.

V2 is a Schmitt trigger. V2-b is held near saturation under steady-state conditions by the voltage divider formed by R8, R10 and R11. V2-b's cathode current flows through R9, causing a high voltage drop across it. This in turn makes V2-a's cathode more positive than its grid, cutting off the tube.

When a signal is applied to V2-a's

grid, nothing happens until the grid voltage approaches the cathode voltage. Then V2-a begins to conduct, forcing V2-b toward cutoff because the increasing voltage drop across R8 forces V2-b's grid to go more negative. Also the increasing cathode current through R9 forces V2-b's cathode to remain at a high positive voltage. Both actions occur almost instantaneously. V2-b remains cut off as long as the input remains above the voltage required to keep V2-a conducting. As soon as the input drops below the critical value, the circuit reverts to its original state.

This switching produces a square-wave output across R12, in phase with the input signal.

Since most sweep generators require a negative pulse rather than a square wave for best sync, the output must be differentiated. This is done by C5 and R13, which form a simple R-C differentiator. The output across R13 is both positive and negative pulses. The positive pulse is clipped by diode D, leaving only the negative pulse. If your scope's sweep generator requires a positive pulse, reverse D.

The reason why C4 is included is not apparent from the description. However, the explanation is simple. At higher frequencies, the time constant formed by R8, R10 and V2-b's input capacitance slows up the transition. By adding C4 across R10, the resistor is shunted by a low impedance at these frequencies, thus speeding up the action.

Construction tips

Parts layout for this circuit is not especially critical, but be sure you keep the amplifier input away from the pulse output. Also, shield the whole circuit to minimize triggering from extraneous pickup, and radiation of pulses into the vertical channel.

I built my unit on a 3 by 3½-inch piece of aluminum which was then mounted on the front lip of the scope chassis. I made a shield for the bottom from a piece of sheet aluminum.

To install the circuit in your scope, first locate the sync selector switch (Fig. 2). Its wiper will probably connect to the sync amplitude control. Disconnect this wire. Connect the sync circuit input to the arm of the selector switch. Connect the output (C5) to the high end of the sync amplitude control (R13 in Fig. 1, replace if resistance is not correct). Connect D across the control, observing polarity. Connect the heater and B-plus leads to convenient points.

Power for the unit can usually be obtained from the scope's main power supply. If this is not possible, a simple transformer half-wave rectifier supply will be ample. END

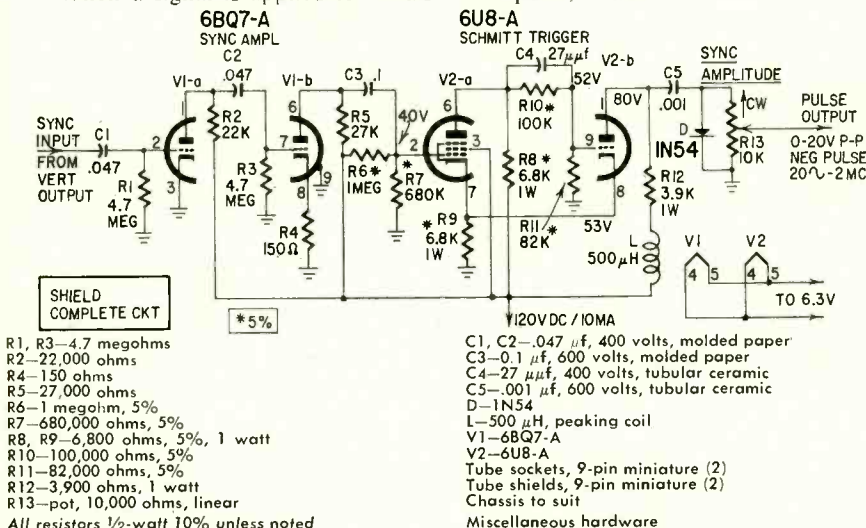

- R1, R3—4.7 megohms
 - R2—22,000 ohms
 - R4—150 ohms
 - R5—27,000 ohms
 - R6—1 megohm, 5%
 - R7—680,000 ohms, 5%
 - R8, R9—6,800 ohms, 5%, 1 watt
 - R10—100,000 ohms, 5%
 - R11—82,000 ohms, 5%
 - R12—3,900 ohms, 1 watt
 - R13—pot, 10,000 ohms, linear
- All resistors ½-watt 10% unless noted

- C1, C2—.047 μf, 400 volts, molded paper
 - C3—0.1 μf, 600 volts, molded paper
 - C4—27 μf, 400 volts, tubular ceramic
 - C5—.001 μf, 600 volts, tubular ceramic
 - D—1N54
 - L—500 μH, peaking coil
 - V1—6BQ7-A
 - V2—6U8-A
- Tube sockets, 9-pin miniature (2)
 Tube shields, 9-pin miniature (2)
 Chassis to suit
 Miscellaneous hardware

Fig. 1—Circuit of sync solidifier. The author reports better results by increasing R6 to 1.1 megohm (5%).

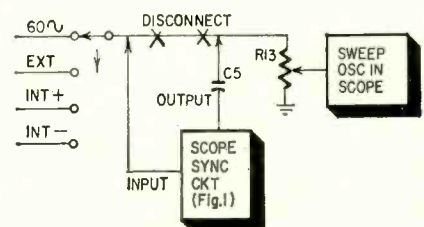

Fig. 2—Where unit goes in scope.

TECHNICIANS' NEWS

RCA Wins NATESA Award

Irving J. Toner, president, National Alliance of Television & Electronic Service Associations (left), presents the NATESA Friends of Service Management Award for 1961 to Douglas Y. Smith, vice president and general man-



ager, RCA Electron Tube Div., and W. Walter Watts, RCA group executive vice president. The award citing RCA's Electron Tube Div. for its outstanding service in creating better customer relations was made by NATESA directors at their 1962 convention.

New Service Data System

The TV Colorgram Service Pak is a new color-coded circuit diagram system that enables the technician to pinpoint TV receiver troubles quickly. It consists of individual Colorgram charts—each illustrating key circuits and signal flow paths in distinctive colors; a color-coded master schematic and a *Rapid Repair Manual*.

Individual 8½ x 11-inch charts cover the following circuit sections: i.f., video, audio, vertical and horizontal sync, B-plus distribution and age circuitry. Each includes voltages, waveforms, test points, component values and signal-flow and continuity patterns. The ground conductor is shown in its own distinctive color.

If the TV technician has a video problem, he selects the video chart; or the horizontal chart when symptoms indicate trouble in this section of the set. The charts are especially helpful when working on sets with printed circuits since each is a replica of the con-

(Continued on page 84)

Tarzian offers FAST, DEPENDABLE TUNER REPAIR SERVICE (ALL MAKES)

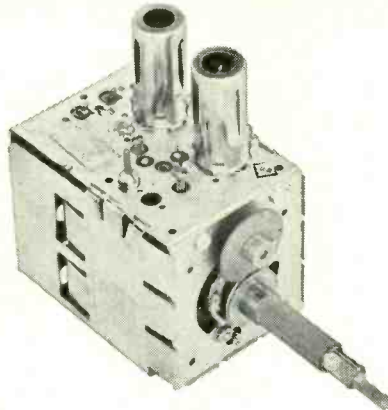

It just makes sense that a manufacturer of tuners should be better-qualified, better-equipped to offer the most dependable tuner repair and overhaul service.

Sarkes Tarzian, Inc. pioneer in the tuner business, maintains two complete, well-equipped Factory Service Centers—assisted by Engineering personnel—and staffed by specialized technicians who handle ONLY tuner repairs on ALL makes and models.

Tarzian-made tuners received one day will be repaired and shipped out the next. Allow a little more time for service on other than Tarzian-made tuners.

Tarzian offers a 12-month guarantee against defective workmanship and parts failure due to normal usage. And, compare our cost of \$9.50 and \$15 for UV combinations. There is absolutely no additional, hidden charge, for ANY parts except tubes. You pay shipping costs. Replacements on tuners beyond practical repair are available at low cost.

Ⓢ Tarzian-made tuners are identified by this stamping. When inquiring about service on other tuners, always give TV make, chassis and Model number. All tuners repaired on approved, open accounts. Check with your local distributor for Sarkes Tarzian replacement tuners, replacement parts, or repair service.



SARKES TARZIAN, INC.

Bloomington, Indiana

MANUFACTURERS OF TUNERS . . . SEMICONDUCTORS . . . AIR TRIMMERS . . . FM RADIOS . . . AM/FM RADIOS . . . AUDIO TAPE . . . BROADCAST EQUIPMENT

ONLY
\$9.50
INCLUDING

ALL PARTS
(except tubes)
and LABOR

24-HOUR SERVICE
1-YEAR WARRANTY

TWO SERVICE CENTERS TO SERVE YOU BETTER

See your distributor, or use the address nearest you for fast factory repair service

537 South Walnut St.
Bloomington, Indiana
Tel: 332-6055

10654 Magnolia Blvd.
North Hollywood, Calif.
Tel: 769-2720

DON'T REPLACE CRYSTALLIZED RUBBER PHONOGRAPH DRIVE WHEELS UNNECESSARILY

brush on **NEW FONO-MAGIC***

eliminate slipping...dragging
SAVES DRIVE WHEEL INVENTORY COSTS TOO!



*FONO-MAGIC is a NEW compound of special rubber and carbide particles. When FONOMAGIC is brushed on metal drive surfaces, it forms a coat of live, pliable non-slipping rubber .000065 inches thick. Carbide particles imbedded in the rubber coating will scratch slipping rubber idler wheels, exposing live rubber and prolonging the life of the idler wheel. Just one bottle of FONOMAGIC is equivalent to the replacement of 100 drive wheels. Only \$1.95 dealer net. Sold at Better Jobbers everywhere.

manufactured by R-COLUMBIA PRODUCTS CO., INC. Highland Park, Illinois

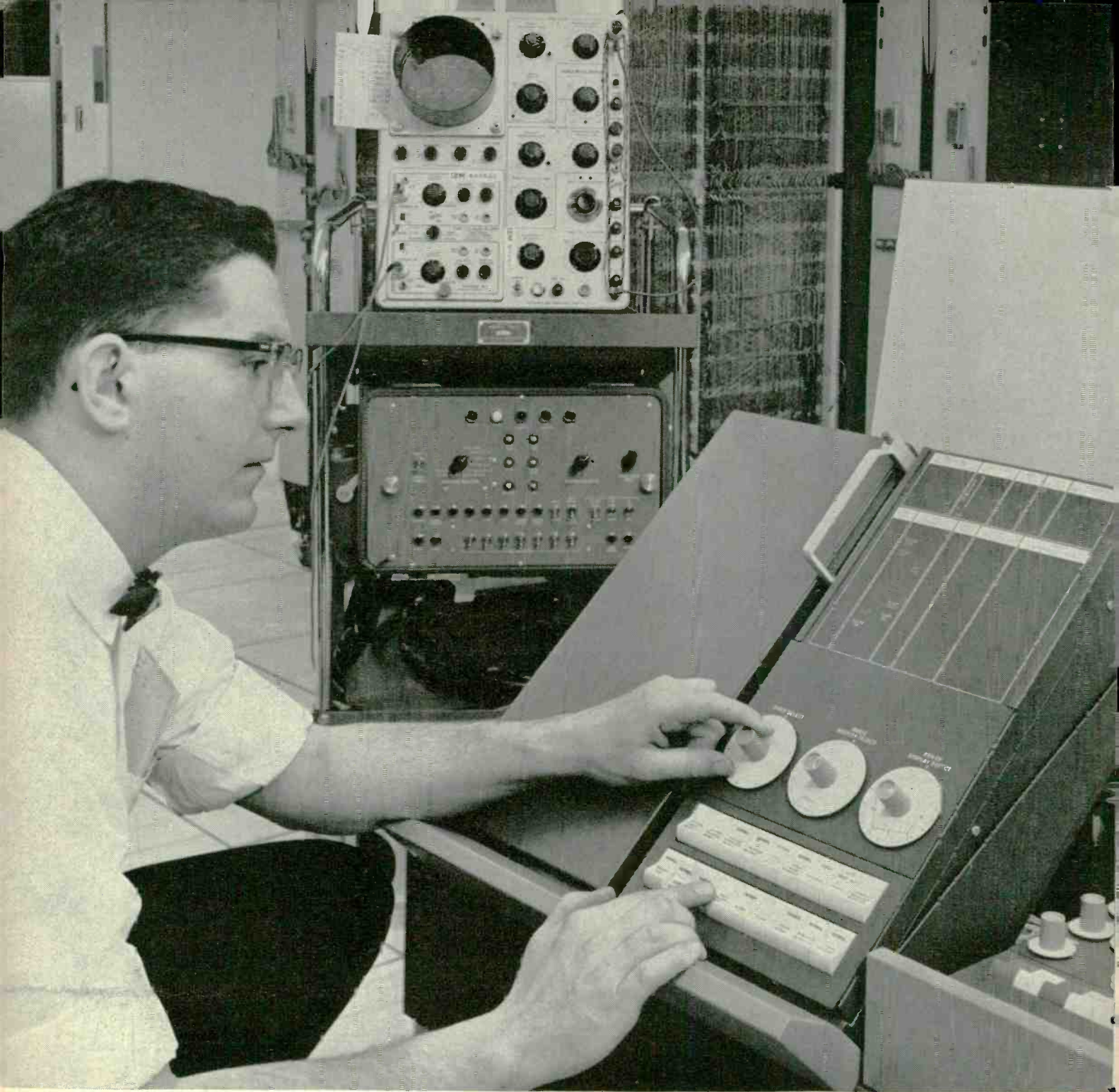

Why Fred got a better job . . .

I laughed when Fred Williams, my old high school buddy and fellow worker, told me he was taking a Cleveland Institute Home Study course in electronics. But when our boss made him Senior Electronic Technician, it made me stop and think. Sure I'm glad Fred got the break . . . but why him . . . and not me? What's he got that I don't. There was only one answer . . . his Cleveland Institute Diploma and his First Class FCC License!

After congratulating Fred on his promotion, I asked him what gives. "I'm going to turn \$10 into \$10,000," he said. "My tuition at Cleveland Institute was only \$10 a month. But, my new job pays me \$10 a week more . . . that's \$520 more a year! In twenty

years . . . even if I don't get another penny increase . . . I will have earned \$10,400 more! It's that simple. I have a plan . . . and it works!"

What a return on his investment! Fred should have been elected **most likely to succeed** . . . he's on the right track. So am I *now*. I sent for my three *free* books a couple of months ago, and I'm well on my way to Fred's level. How about you? Will you be ready like Fred was when opportunity knocks? Take my advice and carefully read the important information on the opposite page. Then check your area of most interest on the postage-free reply card and drop it in the mail *today*, Find out how you can move up in electronics too.

How You Can Succeed In Electronics

. . . Select Your Future From Five Career Programs

The "right" course for your career

Cleveland Institute offers not one, but five different and up-to-date Electronics Home Study Programs. Look them over. Pick the one that is "right" for you. Then mark your selection on the reply card and send it to us. In a few days you will have complete details . . . without obligation.

1. Electronics Technology

A comprehensive program covering Automation, Communications, Computers, Industrial Controls, Television, Transistors, and preparation for a 1st Class FCC License.



2. First Class FCC License

If you want a 1st Class FCC ticket *quickly*, this streamlined program will do the trick and enable you to maintain and service all types of transmitting equipment.



3. Broadcast Engineering

Here's an excellent studio engineering program which will get you a 1st Class FCC License and teach you all about Program Transmission and Broadcast Transmitters.



4. Electronic Communications

Mobile Radio, Microwave, and 2nd Class FCC preparation are just a few of the topics covered in this "compact" program . . . Carrier Telephony too, if you so desire.

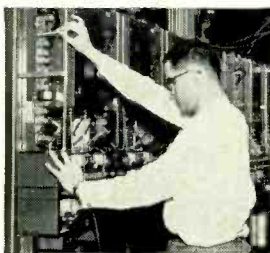

5. Industrial Electronics & Automation

This exciting program includes many important subjects such as Computers, Electronic Heating and Welding, Industrial Controls, Servomechanisms, and Solid State Devices.



An FCC License . . . or your money back!

In addition to providing you with comprehensive training in the area indicated, programs 1, 2, 3, and 4 will prepare you for a Commercial FCC License. In fact, we're so certain of their effectiveness, we make this *exclusive* offer:

The training programs described will prepare you for the FCC License specified. Should you fail to pass the FCC examination after completing the course, we will refund *all* tuition payments. You get an FCC License . . . or your money back!

For Every CIE Student . . . A New Electronics Slide Rule

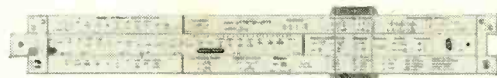

Every CIE student receives this valuable Electronics Slide Rule and complete instructions for its use. As a student . . . and throughout your electronics career, it will save you hours in solving difficult electronics problems.

Job placement service . . . another CIE extra to help you get ahead in electronics

Once enrolled with CIE, you will get a monthly listing of the many high-paying interesting jobs available with top companies throughout the country. Many Cleveland Institute students and graduates hold such jobs with leading companies like these: American Airlines, American Telephone and Telegraph, General Electric, General Telephone and Electronics, IBM, Motorola, North American Aviation, New York Central Railroad, Raytheon, RCA and Westinghouse.

Electronics is a fast moving, dynamic industry . . . Cleveland Institute keeps you current

The Electron Bulletin is CIE's monthly digest of new developments in the world's fastest growing industry. As a CIE student, you will get a free copy throughout your training to keep you up-to-date on Masers, Lasers, Solid State Devices, and other new inventions.



Full accreditation . . . your assurance of competence and integrity

Cleveland Institute of Electronics is accredited by the Accrediting Commission of the National Home Study Council. You can be assured of competent electronics training by a staff of skilled electronics instructors.

**Your Future In Electronics Is
Up To You. Make It A Brighter One.
Mail Reply Card Today.**

Cleveland Institute of Electronics

Dept. RE-76, 1776 E. 17th St., Cleveland 14, Ohio

1,000,000 PARTS BOUGHT FOR THIS

GIANT POLY PAK DOLLAR SALE

FREE OUR JUMBO GIFT PAK WORTH \$15

PLUS \$1 FREE POLY PAK OF YOUR CHOICE

BOTH FREE WITH EVERY \$10 OFFER

- 3 TRANSISTOR V. CONTROL, 1/2 meg.....\$1
- 1000-PC HARDWARE KIT, radio 'n' TV.....\$1
- 60 ASST TUBULAR COND., to .5 mf. to 6 KV.....\$1
- 60 ASST DISC COND., to .03 mf to 6 KV.....\$1
- 50 PLUGS-n-RECEPTACLES, aud. pwr. bty.....\$1
- 50 ASST TUBE SOCKETS, trans. too.....\$1
- 30 HI-Q MOLDED COND., mylar too.....\$1
- 12 TV CHEATER CORDS.....\$1
- 15 SLIDE SWITCHES, just 2A, 115 VAC.....\$1
- 10 TRANSISTOR SOCKETS, pnp-npn.....\$1
- 25 ASST POWER RESISTORS, 5-50W to 7K.....\$1
- 10 PANEL SWITCHES, micro-pot-pwr.....\$1
- 60 ASST MICA COND., silvers too.....\$1
- 40 ASST PRECISION RESISTORS, 1%.....\$1
- 50 ASST RADIO-n-TV KNOBS, coils.....\$1
- 25 ASST TV KNOBS, channels, etc.....\$1
- 10 ASST ELECTROLYTICS, triples too.....\$1
- 10 ASST V. CONTROLS, to 1meg. sw too.....\$1
- 4 SUN BATTERIES, to 1 1/2", lite sens.....\$1
- 10 ASST TRANS ELECTROLYTICS.....\$1
- \$25 RADIO-n-TV SURPRISE, shop must.....\$1
- 50 ASST COILS & CHOKES, if. osc. if.....\$1
- 10 TV-n-FM TRANSFORMERS, ifs. vert.....\$1
- 50 A. BRADLEY RESISTORS, factory sized.....\$1
- 8 TRANSISTOR SOCKETS w/metal flange.....\$1
- 100 ASST 1/2W RESISTORS, factory cut.....\$1
- 100 PARTS SURPRISE, worth \$50.00.....\$1
- 60 HI Q RESISTORS, 1/2, 1, 2W, 1% too.....\$1
- 10 RCA PLUG & JACK SETS, phono. amps.....\$1
- 50 ASST TERM STRIPS, to 12 lugs.....\$1
- 25 ULTRA-MINIATURE CONDENSERS.....\$1
- 35 ASST SILVER MICA COND., 1% too.....\$1
- 10 MICROSWITCHES, by Gen. Elec.....\$1
- 60 CERAMIC CONDS, discs, tubular.....\$1
- 100 PRINTED CIRCUIT PARTS.....\$1
- 40 ASST SUBMINI CONDENSERS.....\$1
- 40 WORLD'S SMALLEST RESISTORS, 1% too.....\$1

SEMI-KON-DUCTORS by POLY PAK

We bought up millions, no chance to test 'em!

- 10 2AMP SILICON RECTIFIERS, axial.....\$1
- 10 2AMP SILICON RECTIFIERS, stud.....\$1
- 20 PNP TRANSISTORS, gold top.....\$1
- 20 NPN TRANSISTORS, gold top.....\$1
- 10 TRANSISTORS, 5pin, 5pin.....\$1
- 5 POWER TRANSISTORS, 2N155 case.....\$1
- 25 'EPOXY' SILICON RECTIFIERS.....\$1
- 25 TOP HAT RECTIFIERS, silicon.....\$1

FACTORY TESTED SEMI-KONS by POLY PAK

- 2 POWER TRANSISTORS, 2N155.....\$1
- 1 40watt STUD POWER TRANSISTOR.....\$1
- 2 PHILCO 30 MC TRANSISTOR, 2N346.....\$1
- 1 20AMP SILICON RECTIFIER, stud.....\$1
- 15 ASST CRYSTAL & SILICON DIODES.....\$1
- 15 SILICON DIODES, color coded.....\$1
- 10 1N34 GERMANIUM DIODES, color coded.....\$1
- 4 SUN BATTERIES to 1 1/2", lite sens.....\$1
- 15 PNP's LIKE 2 N107, CK722.....\$1
- 3 SILICON RECTIFIERS, 750ma, 400V.....\$1
- 2 RCA TRANSISTORS 2N370, worth 1.49 ea.....\$1
- 2 MATCHED PUSH PULL OUTPUT TRANS, pnp.....\$1
- 2 SYLV SILICON TRANSISTORS, osc-conv.....\$1
- 4 2N107 TYPE TRANSISTORS, pnp.....\$1

PRE-TESTED SILICON POWER DIODE STUDS

Amps	Volts	Sale	Amps	Volts	Sale
2	50	\$0.19	35	200	\$2.50
2	100	.34	35	400	3.50
2	200	.44	50	10	1.49
2	400	.77	50	25	1.95
2	600	.88	50	50	2.88
2	800	1.49	50	100	3.95
1	50	.88	50	200	4.49
1	100	.99	100	10	1.95
1	200	1.25	100	25	2.49
1	400	1.88	100	50	3.50
1	600	2.50	100	100	4.50
35	50	1.77	100	200	4.57
35	100	1.95			

SEND 10¢ FOR BARGAIN MAIL-ORDER FLYERS

Semiconductors Poly Paks Parts

POLY PAKS

TERMS: Send check, money order, incl postage—avg wt per pak 1 lb. Rated firms, net 30 days. EXPORT ORDERS INVITED.

P.O. Box 942R, So Lynnfield, Mass. World's largest supplier of pre-packed assortments

(Continued from page 79)

ductor pattern. A component-location guide lists each part according to its position with respect to vertical and horizontal guide lines on the chart. This makes it easy to pinpoint hard-to-find components.

The master schematic shows all circuit sections in the same colors as on the Colorgram charts. It also includes test points, waveforms, voltages, and parts values. The *Rapid Repair Manual* contains official manufacturers' service notes, special instructions, production



changes, circuit modifications, parts lists, tube and component location charts and a tube-failure guide.

TV Colorgrams, developed by former service technician and later technical editor Bob Cornell, and introduced by Colorgrams, Inc., a subsidiary of TV Development Corp., Mineola, N. Y., will initially cover the most popu-

lar RCA, G-E, Admiral, Westinghouse, Philco, Emerson and Magnavox TV chassis. They will be sold through electronic parts dealers at \$1.95 per Service Pak.

Service Group Pays \$1,000 Fine

Officers of the Brooklyn Radio & Television Service Guild agreed to a \$1,000 settlement and accepted a permanent injunction against violating New York State anti-trust laws. The group was charged with obtaining agreements among service technicians on a fixed price for TV service calls.

Telsa New Britain Formed

New Britain, Conn.—Local TV service dealers held a reorganization meeting, whose purpose was to form an active local of Telsa of Connecticut. The meeting was successful, and a slate of officers was elected. Henry J. Olzewski is president of the new group; William Brighenti, vice president; Richard M. Houghton, secretary, and John Sidoti, treasurer. The organization has been accepted into the State Chapter of Telsa.

TV Antenna Liabilities

TESA King County, Washington, uses the Weather Bureau's table of wind velocities in determining liability and defining guarantee limits covering an-

IEEE MEET

THE BEST BRAINS,
THE BEST PRODUCTS
IN THE INDUSTRY
at

I-TRIPLE-E'S

International Convention
and Exhibition in New York

MARCH 25, 26, 27, 28

The COLISEUM at Columbus Circle
& The WALDORF ASTORIA HOTEL

admission: MEMBERS \$1.00; NON-MEMBERS \$3.00
MINIMUM AGE: 18

SHOW

(formerly the IRE Show)

TELL YOUR FRIENDS ABOUT Radio-Electronics

tenna installations suffering wind damage. TSA guarantees, approved by the Seattle Better Business Bureau, cover antenna installations in winds up to gale force (39 to 54 miles per hour), as rated by local Weather Bureau reports.

Sylvania Reduces Warranty Period

This firm's new reduced warranty coverage is encouraging to technicians massing opposition to the extended warranty policies adopted or proposed by some manufacturers. The firm's new policy provides a 90-day warranty on parts and labor on conventional tube and transistor radios. Previously, Sylvania's transistor radios carried a 5-year warranty on parts and labor and 1-year coverage on tube sets.

Technician Restores Pipe Organs

Chicago, Ill.—Irv Toner, the newly elected president of NATESA (National Alliance of Television & Electronic Service Associations) has one rather unusual hobby—he restores old pipe organs of the type used in theaters. In fact, he heads an organization called "American Theater Organ Enthusiasts."

Speaking about service technicians, Mr. Toner points out that his pet peeve is "the extreme number of un-

qualified service men who get into the field. They use up their life's savings before they become qualified. Largely responsible for these unqualified service men are the technical schools who are turning them out."

"To enter the service business," he continued, "an individual must be technically qualified, have business know-how, capital, and experience (working with some other service dealer, something like an interne in a hospital)."

Toner went on to say that the biggest problem facing the service industry is its poor public image, plus a rather ridiculous dealer-distributor relationship, whereby the consumer is able to buy at dealer prices. Toner puts the blame for this situation on the manufacturer. He thinks that passage of the price-quality-stability bill would be helpful in solving this problem.

FTRSAP Working with NARDA

The Federation of Television & Radio Service Associations of Pennsylvania (FTRSAP) named Joseph Doyle, its Pittsburgh delegate, to represent the federation at the NARDA (National Appliance & Radio-TV Dealers Associations) convention in Chicago in January. Mr. Doyle has plans for joint FTRSAP-NARDA action in a nationwide campaign against extended war-

ranties. The plans were drafted along the lines of information required by the Federal Trade Commission. **END**

50 Years Ago

In Gernsback Publications

HUGO GERNSBACK, Founder

Modern Electrics	1908
Wireless Association of America	1908
Electrical Experimenter	1913
Radio News	1919
Science & Invention	1920
Practical Electrics	1921
Television	1927
Radio Craft	1929
Short-Wave Craft	1930
Television News	1931

Some larger libraries still have copies of Modern Electrics on file for interested readers.

In February, 1913 Modern Electrics

- The Lepel Quenched Spark System, by Stanley E. Hyde.
- Wireless and the Amateur—A Retrospect, by H. Gernsback.
- A Series Spark-Gap, by P. Mertz.
- The Audion Detector, by B. N. Burglund.
- Honolulu Greets Washington by Wireless.
- Thirty-Five Mile Wireless Talk.
- New Battery Wireless Telephone, by W. R. Organ.
- Converting A Double-Slide Tuner Into a Loose Coupler, by P. Mertz.
- Variometer, by Page Haselton.
- Real Improvement in Detectors, by W. R. Organ.

TV-RADIO Servicemen or Beginners...

Send for *Coyne's*
7-Volume Job-Training Set
on 7-Day **FREE TRIAL!**



The First
Practical
TV-RADIO-
ELECTRONICS
Shop
Library!

Answers ALL Servicing Problems QUICKLY . . .
Makes You Worth More On The Job!

Put money-making, time-saving TV-RADIO-ELECTRONICS know-how at your fingertips—examine Coyne's all-new 7-Volume TV-RADIO-ELECTRONICS Reference Set for 7 days at our expense! Shows you the way to easier TV-Radio repair—time saving, practical working knowledge that helps you get the BIG money! How to install, service and align ALL radio and TV sets, even color-TV, UHF, FM and transistorized equipment. New photo-instruction shows you what makes equipment "tick". No complicated math or theory—just practical facts you can put to use immediately right in the shop, or for ready reference at home. Over 3000 pages; 1200 diagrams; 10,000 facts!

SEND NO MONEY! Just mail coupon for 7-Volume TV-Radio Set on 7-Day FREE TRIAL! We'll include the FREE BOOK below. If you keep the set, pay only \$3 in 7 days and \$3 per month until \$27.25 plus postage is paid. Cash price only \$24.95. Or return set at our expense in 7 days and owe nothing. Either way, the FREE BOOK is yours to keep. Offer limited, so act NOW!

"LEARNED MORE FROM THEM THAN FROM 5 YEARS WORK!"

"Learned more from your first two volumes than from 5 years work."
—Guy Bliss, New York
"Swell set for either the serviceman or the beginner. Every service bench should have one."
—Melvin Masbruch, Iowa.

FREE DIAGRAM BOOK!

We'll send you this big book, "150 Radio-Television Picture Patterns and Diagrams Explained" ABSOLUTELY FREE just for examining Coyne's 7-Volume Shop Library on 7-Day FREE TRIAL! Shows how to cut servicing time by reading picture-patterns, plus schematic diagrams for many TV and radio sets. Yours FREE whether you keep the 7-Volume Set or not! Mail coupon TODAY!

Like Having An Electronics Expert Right At Your Side!

- VOL. 1—EVERYTHING ON TV-RADIO PRINCIPLES!** 300 pages of practical explanations; hundreds of illustrations.
- VOL. 2—EVERYTHING ON TV-RADIO-FM RECEIVERS;** 403 pages; fully illustrated.
- VOL. 3—EVERYTHING ON TV-RADIO CIRCUITS!** 336 pages; hundreds of illustrations, circuit diagrams.
- VOL. 4—EVERYTHING ON SERVICING INSTRUMENTS!** How they work, how to use them. 368 pages; illustrated.
- VOL. 5—EVERYTHING ON TV TROUBLESHOOTING!** Covers all types of sets. 437 pages; illustrations, diagrams.
- VOL. 6—TV CYCLOPEDIA!** Quick and concise answers to TV problems in alphabetical order, including UHF, Color TV and Transistors; 868 pages.
- VOL. 7—TRANSISTOR CIRCUIT HANDBOOK!** Practical Reference covering Transistor Applications; over 200 Circuit Diagrams; 410 pages.

ALL 7 BOOKS HAVE BRIGHT, MODERN, VINYL CLOTH WASHABLE COVERS

FREE BOOK—FREE TRIAL COUPON!

Educational Book Publishing Division
COYNE SCHOOL PUBLICATIONS
1455 W. Congress Parkway, Dept. 23-RE, Chicago 7, Illinois
Yes! Send me COYNE'S 7-Volume Applied Practical TV-RADIO-ELECTRONICS Set for 7-Days FREE TRIAL per your offer. Include "Patterns & Diagrams" book FREE!

Name Age

Address

City Zone State

Check here if you want Set sent C.O.D. Coyne pays postage on C.O.D. and cash orders. 7-Day Money-Back Guarantee.

Coyne ELECTRICAL SCHOOL 1455 W. Congress Parkway
Dept. 23-RE, Chicago 7, Illinois

In the March, 1963, issue, we're coming in (and staying in) like a lion. You'll roar your delight at the projects you can construct, ideas you can glean, and the hints and kinks you can use in your shop or shack. Here's real reading prey for any royally maned electronics man (and beardless types, too!):



ELECTRONICS RANGE IN THE HOME

Electronics technicians will find repair and maintenance of microwave oven ranges simplicity itself after reading this descriptive article. This new type of cooking range is a housewife's delight. Hamburgers will cook in seconds; a roast, in minutes, with no fear of burn or kitchen heat. Learn microwave range repair before customers call.

BUILD THE AUTOGEN

An excellent beginner's project; old-timers will get a nostalgic kick constructing this unusually selective and sensitive one-transistor regenerative receiver.

HOW TO HANDLE UHF TV

All TV receivers manufactured after April 30, 1964, are required by Act of Congress to have all-channel tuners included in sets. Are you ready for them? Learn uhf installation, conversion from vhf to vhf-uhf where possible, and quirks and problems in installation and repair maintenance. Get ready now! Uhf is coming!

MAKE YOUR METER MORE SENSITIVE

A simple adapter will increase the sensitivity of conventional volt-ohm-milliammeter so it will measure millivolts and microamperes. Why spend money for ultra-sensitive meter when the one you have will do the job with this modification?

HIGH-GAIN ANTENNA FOR FM

Build this antenna designed along the lines of a broadcast transmitter type but at one-tenth the weight and a fraction of the cost. Cut to correct lengths, the antenna will work on TV bands or other frequencies. Perfect for hi-fi systems. Can be directional or omnidirectional as desired by simply changing the design. What good is your top equipment without a first-class antenna?

Radio-Electronics
March Issue On Sale February 21

NEW LITERATURE

CATALOGS • BOOKLETS • CHARTS

SOUND-LEVEL METER, model 2203, shown in 8-page technical brochure. Full specs, application data, many accessories.—**B & K Instruments Inc.**, 3044 106th St., Cleveland 11, Ohio.

TRANSFORMERS, CHOKES featured in 48-page *Catalog No. 63*. Specs on MIL spec rf chokes, i.f. transformers, adjustable coils wound on ceramic and Resinite materials, exact replacement coils. More than 1,500 items. Many illustrations.—**J. W. Miller Co.**, 5917 S. Main St., Los Angeles 3, Calif.

SEMICONDUCTOR GUIDE. 4-page leaflet lists transistors, silicon rectifiers and power varactor diodes by type number, with electrical characteristics and case type.—**Dr. R. R. Meijer, Manager, Product Planning, Bendix Semiconductor Div.**, South St., Holmdel, N. J.

TEST INSTRUMENTS. 25 major items plus accessories offered in 8-page *Catalog No. 44-T*. Photos and specs on vom's, vtvm's, tube and transistor analyzers, others.—**Triplett Electrical Instrument Co.**, Bluffton, Ohio.

BATTERY MANUAL, *Booklet BDG-111*. 62-page catalog offers detailed information on dry batteries. Includes classification chart, service-life data table, mechanical and electrical characteristics, dimensional outlines, terminal connections for each type. Theory section outlines history of dry cells and explanation of basic types. 50¢.—**Commercial Engineering Activity, RCA Electron Tube Div.**, Harrison, N. J.

THERMISTORS, THYRISTOR VARISTORS detailed in *Product Data Sheets 3201, 9201, respectively*. Illustrated sheets give outline drawings, photos, application data, complete specs.—**General Electric Co.**, Magnetic Materials Section, PO Box 72, Edmore, Mich.

INDUSTRIAL ELECTRONIC SUPPLIES listed in 664-page *Catalog 630*. Many photos, full specs, product and manufacturer's indexes. Items include amateur equipment, audio supplies, selection of construction kits, PA equipment, soldering devices, test instruments, many other items. Industrial buyers request on letterhead.—**Allied Electronics, Div. Allied Radio**, 100 N. Western Ave., Chicago 80, Ill.

AIR-CORE INDUCTORS. 10-page illustrated folder lists Air Dux inductors for amateur rigs or prototypes of rf transmission equipment. Includes technical data on coils for pi output circuits, conventional L-C output interstage and oscillator circuits.—**Illumitronic Engineering Corp.**, 680 E. Taylor Ave., Sunnyvale, Calif.

TOUCH CONTROL SWITCH offered in 6-page illustrated brochure. Block diagram explains circuit operation of the capacitance-operated device. Electrical and physical specs included. Other types of Dynaquad modules also described.—**Tung-sol Electric Inc.**, 1 Summer Ave., Newark 4, N. J.

CB BROCHURE, *Over a Quarter of a Century in Electronics*, describes manufacturer's history and methods in CB production. Full-color photos, complete specs and descriptions of 5 CB products.—**Browning Labs, Inc.**, 100 Union Ave., Laconia, N. H.

SILICON RECTIFIERS, voltage impulse protected (V.I.P.) types, described in 4-page leaflet. Controlled avalanche enables these rectifiers to withstand transient voltages higher than the rated peak reverse voltage. Leaflet gives avalanche characteristics, maximum ratings, electrical specs.—**General Instrument Corp.**, Rectifier Div., 65 Gouverneur St., Newark 4, N. J.

LOW-TORQUE VARIABLE CAPACITORS presented in illustrated spec sheet, *Bulletin CO-1T*. Four types include capacitors with .020- and .040-inch plate spacing, differential and dynamically balanced caps with .020-inch plate spacing. Large photos, engineering drawings.—**National Radio Co. Inc.**, Dept. P, 37 Washington St., Melrose, Mass.

STOCK PANEL METERS presented in 16-page *Bulletin 2063*. Offers over 1300 meters carried in stock, including voltmeters, ammeters, microammeters 1-1/2 to 6 in., elapsed-time meters, ex-

panded-scale voltmeters. 4-page glossary.—**Simpson Electric Co.**, Dept. VR, 5200 W. Kinzie St., Chicago 44, Ill.

DIGITAL BUILDING BLOCKS, transistor and magnetic core, illustrated in 14-page catalog. Includes complete specs, rules for logic and loading, assembly data. Shows Sew-A-Circuit and other construction aids.—**Magnetics Research Co., Inc.**, 179 Westmoreland Ave., White Plains, N. Y.

SILICON RECTIFIERS, Controlled rectifiers, voltage regulators outlined in 10-page *Semiconductor Catalog*. Many photos, complete specs.—**North American Electronics Inc.**, 71 Linden St., West Lynn, Mass.

STEREO HEADPHONES and accessories described in foldup *Brochure MH*. Features headphone remote-control center and cross-feed network.—**Jensen Manufacturing Co.**, 6601 S. Laramie, Chicago, Ill.

REFERENCE CARD FOR CB-ERS. 5 1/2 x 7-in. card lists complete National CB Standard 10 Code. Spaces provided for recording calls.—**Vocaline Co. of America, Inc.**, Old Saybrook, Conn.

SUBMINIATURE STRAP FRAME GRID TUBES FOR MILITARY AND INDUSTRIAL APPLICATIONS, Vol 1. 42-page, 8 1/2 x 11-in. booklet contains brief description of 10 new tube types, circuits of basic building-block applications and performance data. Data sheets give mechanical and electrical ratings, average characteristics, basing connections, etc.—**Sylvania Electric Products, Inc.**, 730 3rd Ave., New York 17, N. Y. END

Any or all of these catalogs, bulletins, or periodicals are available to you on request direct to the manufacturers, whose addresses are listed at the end of each item. Use your letterhead—do not use postcards. To facilitate identification, mention the issue and page of RADIO-ELECTRONICS on which the item appears. UNLESS OTHERWISE STATED, ALL ITEMS ARE GRATIS. ALL LITERATURE OFFERS ARE VOID AFTER SIX MONTHS.

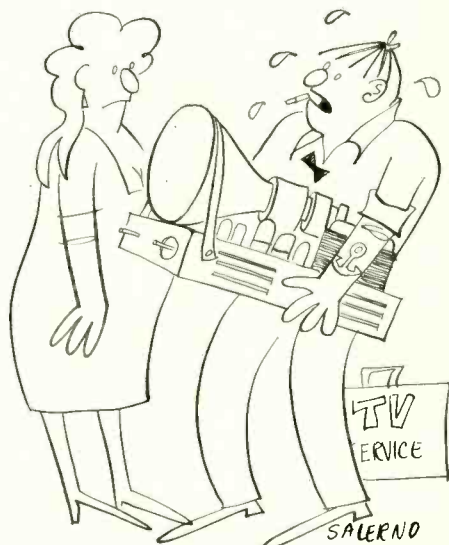

"They aren't making them the way they used to—thank God!"

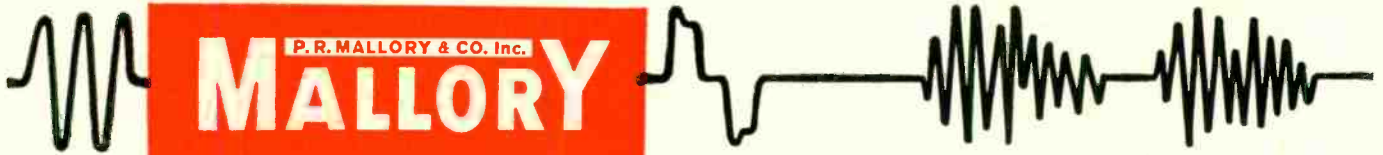

Tips for Technicians

Mallory Distributor Products Company
P. O. Box 1558, Indianapolis 6, Indiana
a division of P. R. Mallory & Co. Inc.

Getting "unusual" coefficients in temperature compensating ceramics

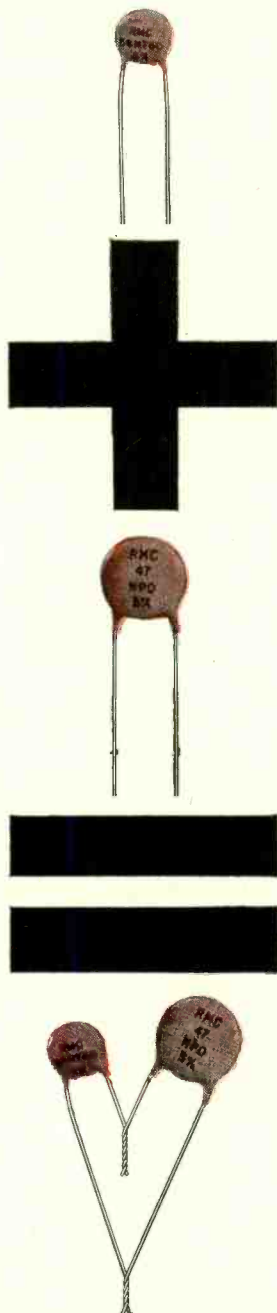

When you're putting a temperature stabilizing ceramic capacitor in an oscillator circuit to eliminate frequency drift during warm-up, you'll find sometimes that the standard negative coefficient of the capacitor just doesn't match what your circuit needs. Instead of an N750—the usual standard value—you may need an N150 or N300. But you just can't get those odd values every time you look for them.

There's a simple way to tailor-make your own compensating capacitor, by paralleling standard NPO (zero coefficient) and N750 (negative 750 parts per million per degree) units.

Here's how it works. Multiply the capacity you need in mmfd by the desired temperature coefficient. Then divide the answer by 750. The result is the mmfd value of the N750 unit in the parallel combination. To find the value of the NPO unit, subtract the N750 value you've just calculated from the total capacity you need.

Suppose you're looking for 100 mmfd with a temperature coefficient of N330. The calculations go like this:

- (1) Multiply: $100 \times 330 = 33,000$.
- (2) Divide: $33,000 \div 750 = 44$ mmfd; this is the N750 value.
- (3) Subtract: $100 - 44 = 56$ mmfd; this is the NPO value.

Get yourself a standard 47 mmfd NPO (Discap® CNO-447), the nearest standard value to 44 mmfd, and a 56 mmfd N750 (Discap CN7-456). Twist the leads together, solder them in place . . . and you're in business.

And here's another tip. Make sure you use Discaps whenever you need a ceramic capacitor. They're made by Radio Materials Company, a Mallory division, world's largest manufacturer of ceramic capacitors. They're available in every imaginable rating at your Mallory distributor . . . in temperature compensating, general purpose, buffer, miniature, high voltage, trimmer and feed-through types. Most popular types come in the handy file card five-pack.

Make your Mallory distributor your headquarters for Discaps, for Mallory electrolytics, tubular capacitors, controls, resistors, batteries, silicon rectifiers, switches and vibrators.

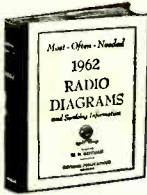

AMAZING OFFER RADIO & TV SERVICE DATA

Your best, complete source for all needed RADIO and TV diagrams and servicing data. Most amazing values. Only \$2.50 and \$3 per giant volume. Cover all important makes, models of all periods. Use this entire ad as your *no-risk* order form.

NO-RISK ORDER COUPON

TELEVISION SERVICE MANUALS

Supreme TV manuals are best for faster, easier TV repairs. Lowest priced. Factory data on practically all sets. Complete circuits, all needed alignment facts, wiring board views, waveforms, voltages, production changes, and double-page schematics. Only \$3 per large annual manual. Check volumes wanted, send entire advertisement as your order form.

- New Additional 1962 Television Manual..... \$3.
- Early 1962 Television Servicing Manual, only \$3.
- 1961 TV Manual, \$3. 1960 TV Manual, \$3.
- Additional 1959 TV, \$3. Early 1959 TV, \$3.
- 1958 TV Manual, \$3. Additional 1957 TV, \$3.
- Early 1957 Television, \$3. 1956 TV Manual, \$3.
- Additional 1955 TV, \$3. Early 1955 TV, \$3.
- 1954 TV, \$3. 1953 TV, \$3. 1952 TV, \$3.
- 1951 TV, \$3. Master Index to all Manuals, 25c

RADIO DIAGRAM MANUALS

Here are low-priced radio manuals that simplify repairing. Cover everything from most recent 1963 radios to pre-war old-timers; home radios, stereo, combinations, transistor portables, FM, auto sets. Large schematics, all needed alignment facts, printed boards, voltages, dial stringing, hints. Volumes are big. 8½ x 11", about 190 pages, each.

\$2.50

- 1963, 1962, 1961, 1960, 1959, 1958,
- 1957, 1956, 1955, 1954, 1953, 1952,
- 1951, 1950, 1949, 1948, 1947, 1946,
- 1942, 1941, 1940, 1926-38 EACH, \$2.50

SUPREME PUBLICATIONS

1760 Balsam Road Highland Park, Ill.

Rush today TV and Radio manuals checked in no-risk order form of this ad. Send postpaid, I am enclosing full price. You guarantee my complete satisfaction or my money back.

Name: _____

Address: _____

City: _____ State: _____

GREGORY ELECTRONICS WINTER SPECIALS!

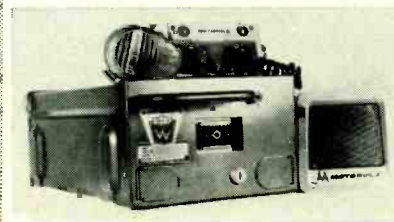

MOTOROLA 30-50mc
T41-GGV or T41G1A rear
mount 6/12v, 30 watt, narrow
banded, complete with all ac-
cessories, less crystal & anten-
na. Add \$25 for crystals & tun-
ing.

\$198

MOTOROLA 450-470mc
T44-12 volts, less accessories.

\$95

ALL ACCESSORIES for above,
less crystals and antenna.

\$35

GUARANTEED RECONDITIONED
FM 2-WAY MOBILE RADIOS
G-E, RCA, MOTOROLA & OTHERS!
LOW, HIGH & UHF BANDS
Write For New 1963 Catalog

WANTED... FOR CASH!

Late model 2-way radio equipment
State price, condition, quality.

**GREGORY
ELECTRONICS
CORPORATION**



112 Route 46 Saddle Brook, N. J.
Phone PR 3-7550

NEW SEMI CONDUCTORS & TUBES

WE BEGIN THIS MONTH WITH A FEW semiconductor diodes and transistors. Then a new horizontal output tube, a special writing and data-display CRT and a special semiconductor diode designed to emit infrared rays.

2N2492

A p-n-p alloy junction transistor for high-power dc-to-dc converters, dc-to-ac inverters, regulated power supplies, motor controls, servo drivers and high-power switches.

The absolute maximum characteristics of this Tung-Sol transistor are:

V _{CB0}	— 80
V _{CES} (I _C = 300 ma)	— 75
V _{EBO}	— 60
I _C (amps)	15
P _C (watts)	170

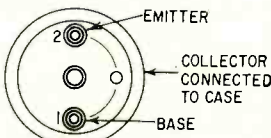
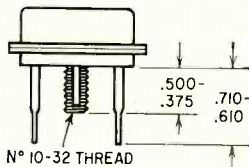
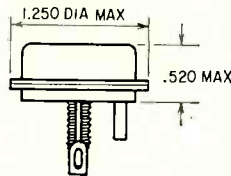

2N2492

Typical switching application:

V _{CC}	75
I _C (amps, on)	12
R _L (ohms)	6.25
I _B (amps, on)	2
P _C (watts, on)	4.8
G _p (db)	26.5

2N2374, 2N2375, 2N2376

Germanium-alloy p-n-p junction transistors for medium-power audio driver and output stages in auto and portable radio and communications applications. The 2N2376 is a matched pair

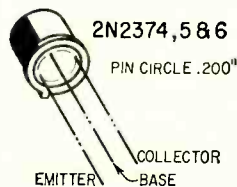

of 2N2375's used in push-pull output stages. They feature an especially linear beta over a wide range of operating conditions. Noise figure is very low at currents down to a few hundred μ a.

The ratings of these Philco transistors are:

	2N2374	2N2375
V _{CB}	— 35	— 35
V _{EB}	— 35	— 35
V _{CES}	— 35	— 35
I _C (ma)	500	500
P _{total} (mw at 25°C)	250	250
f _{hfb} (mc)	15	9
h _{fe} (typical)	210	95

2N2288, 2N2289, 2N2290

Diffused-alloy power DAP transistors for high-current switching at high frequencies. Suitable for hi-fi am-

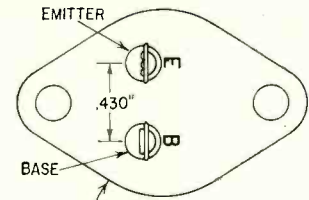

COLLECTOR CONNECTED TO CASE
2N2288, 2N2289, 2N2290

plifiers, TV horizontal output amplifiers and power converters.

Absolute maximum ratings on these Bendix transistors are:

	2N2288	2N2289	2N2290
V _{CB}	40	80	120
V _{EB}	40	80	120
I _C (amps)	10	10	10
P _C (watts)	60	60	60

150-amp controlled rectifier

This unit is designed for high-power industrial and military applications and can be obtained with forward-blocking voltages through 400.

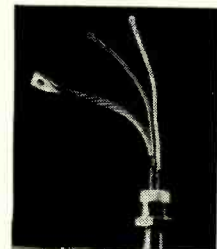

Westinghouse rates this unit, called the 200 Trinistor, at 150 amps for 180° conduction and a case temperature of 85°C. The rms rating is 235 amps and the surge-current rating 3,500 amps.

It can be used to control power inverters, converters, frequency changers, battery chargers and light-dimming and magnetic amplifier equipment.

6JB6, 12JB6, 17JB6

Novar beam-power tubes for TV horizontal-deflection amplifiers. They are especially designed for minimum interference from "snivets" (one or more dark vertical lines near the right edge of a TV picture, caused by spurious oscillations in the horizontal output stage being picked up by the front end

and displayed on the screen). This is done by applying a positive voltage to grid 3, which is brought out to a separate pin on the base.

The three tubes are electrically identical except for their heaters. The

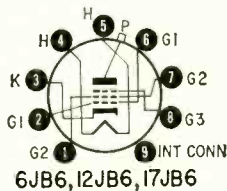

12JB6 and 17JB6 have controlled-warmup for series heater strings. The 6JB6 has a 6.3-volt 1.2 amp heater. The 12JB6 has a 12.6-volt 600-ma heater. The 17JB6's heater is rated at 16.8 volts 450 ma.

Maximum ratings for these RCA tubes are:

V_p (boost and dc)	770
V_{G3}	70
V_{G2}	220
P_p (watts)	17.5
P_{G2} (watts)	3.5
I_k (average ma)	175
(peak ma)	500

SC-3185

This is a 21-inch direct-view rectangular cathode-ray tube for character writing and data display. The Sylvania tube has two pairs of high-sensitivity, limited-scan electrostatic deflection plates for writing alpha-numeric

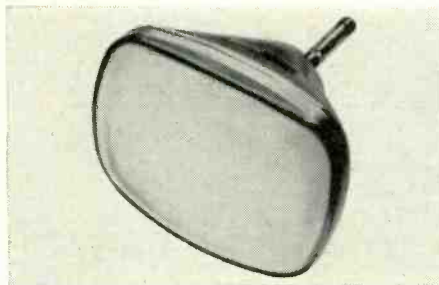

characters and symbols.

A 72° magnetic deflection system is used for positioning the characters and for full-screen scanning. The tube is made with long-persistence P7 and P19 phosphors but can be supplied in several other types.

SNX-100

A gallium arsenide infrared source diode is available from Texas Instruments for experimental engineering evaluation. Designed as a source in communication links, infrared radar equipment and for tape and card readers in computers. The SNX-100 operates as a forward-biased diode and emits light in a narrow band in the near infrared. Its output can be modulated by varying the forward bias current. Modulation range is 0 to 900 mc. Quantum efficiency (the ratio of photons leaving the device to electrons entering) ranges from .03% at 25°C to 0.3% at -195°C. END

FREE Catalog

**OF THE WORLD'S FINEST
ELECTRONIC GOV'T
SURPLUS BARGAINS**

HUNDREDS OF TOP QUALITY ITEMS— Receivers, Transmitters, Microphones, Inverters, Power Supplies, Meters, Phones, Antennas, Indicators, Filters, Transformers, Amplifiers, Headsets, Converters, Control Boxes, Dynamometers, Test Equipment, Motors, Blowers, Cable, Keys, Chokes, Handsets, Switches, etc., etc. Send for Free Catalog—Dept. RE.

FAIR RADIO SALES
2133 ELIDA RD. • Box 1105 • LIMA, OHIO

AMPLIFIERS

Stereo 14W. \$29.95, Radio-TV-Components FREE CATALOG

GM PHOTOELECTRONICS
623 So. Gay Street Knoxville 2, Tenn.

Convert any television to sensitive, **BIG-SCREEN OSCILLOSCOPE** with minor, inexpensive changes. Ingenious circuit. No electronic experience needed to follow our clearly illustrated plans. **TECHNICIANS, HAMs, EXPERIMENTERS, BROADCASTERS.** Use in shop, school, lab. Any set—any size screen.

FULL PLANS \$2.
RELCO, Dept. RE-2, Box 10563, Houston 18, Tex.

The next microphone you buy should be a Turner...

... partly because Turner microphones work better and last longer.
... partly because they are specially designed for convenience in specific jobs.
... but mainly because you get more microphone for your money in a Turner.

TURNER 404



**FOR
STUDIO
QUALITY**

Typical of Turner microphone value is this studio quality dynamic microphone, priced for home recording budgets. You'll find the 404 delivers noticeably improved sound reproduction in either voice or music recording. Response: 50-13,000 cps; Output -60 db, combination impedance, line shorting, recessed switch. For complete technical specifications, mail coupon or use reader service card. We'll send you the Turner value story on these three microphones as fast as the mail will carry it.

TURNER 350C FOR CB AND MOBILE



CB'ers and hams have remarked about this remarkable mobile microphone. "Why pay more when the 350C is available?" No wonder the 350C is the most popular microphone in CB... used as original equipment with more transceivers than any other microphone. Response: 80-7000 cps; Output -54 db. List price \$16.80. Mail coupon for complete specs.

TURNER 80 FOR HAND, STAND OR DESK



Beauty in design plus operational dependability made the slender, graceful Turner 80 one of the most popular, low cost microphones on the market for general purpose use. Weighs only 5 ounces. Only 4 1/4" in length. Response: 80-7000 cps; Output -54 db. List price \$15.95 (less stand). Mail coupon for complete specifications, or ask for the Turner 80 at your nearest electronics parts distributor's counter.

MAIL THIS COUPON TODAY FOR FREE LITERATURE

THE TURNER MICROPHONE COMPANY
933 17th Street N.E.
Cedar Rapids, Iowa

IN CANADA: Tri-Tel Associates
81 Sheppard Ave., West, Willowdale, Ont.
EXPORT: Ad Auriema, Inc.
85 Broad Street, New York 4, N. Y.

Name

Address

City State

1963 Edition
available at your local distributor
get your copy today!

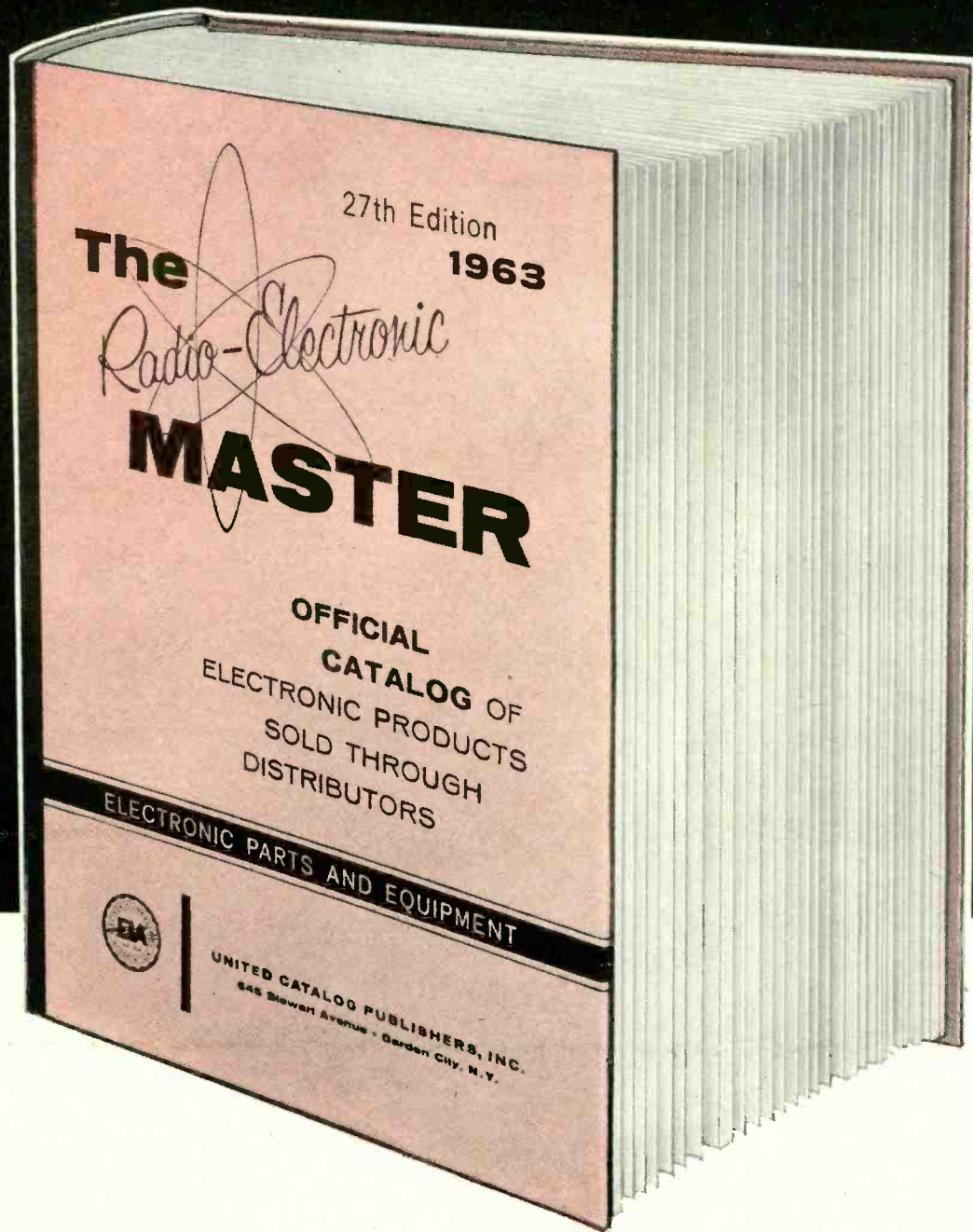

1680
PAGES

\$3.95
from electronic
distributors
\$4.95 in Canada

world's largest electronic catalog!

the catalog with every standard electronic part you'll need

FIND THESE PRODUCTS FASTER IN THE MASTER

- Antennas
- Hi-Fi & Audio Equipment
- Cabinets, Chassis, Racks
- Capacitors
- Chemicals
- Citizens Band Equipment
- Coils
- Communications Equipment

- Connectors
- Controls, Timers
- Crystals
- Dials & Knobs
- Fans & Blowers
- Hardware
- Insulators
- Kits

- Test & Measuring Instruments
- Motors
- Packaged Circuits
- Photoelectric Equipment
- Pilot Lamps
- Power Supplies
- Publications
- Rectifiers

- Relays
- Resistors
- Semiconductors
- Switches
- Tools
- Transformers
- Tubes
- Wire & Cable

NO MORE HUNTING THROUGH PILES OF LITERATURE OR SMALL CATALOGS

1680 pages illustrate and describe every product you'll ever need for buying, specifying, designing, servicing, kit building, experimenting — anything that you do in the field of electronics. And, its all in one big catalog. No need to look through piles of literature or go from small catalog to small catalog. The MASTER has more information on each product and contains more products than any other electronic catalog. The MASTER answers these questions:

*What product best fills my needs?
What does it look like?
How does it compare?
Who makes it?
What does it cost?*

185,000
Items

32 Product
Sections

Descriptions
Specifications
Prices

12,500
Illustrations

308
Manufacturers

Foreign Tube
Substitution
Guide

15 WAYS

the new 1963 MASTER helps engineers, servicemen, buyers, hobbyists

1. Saves "shopping" time — no looking from catalog to catalog, no wading through piles of literature for the product you want. It's all in The MASTER.
2. Aids in selecting the right product to do the job best — comparison of specs, features, prices of many makes of similar type products is simplified. All similar products in same product section.
3. Leads to extra service income — in addition to radio-TV products, The MASTER describes in detail thousands of products for profitable hi-fi, sound and industrial servicing.
4. Includes new items indispensable in servicing — new sub-miniature and printed circuit components, new color TV and hi-fi test instruments.
5. Increases profits for service technicians — buy and sell direct from the MASTER. It contains prices.
6. Guides radio amateurs — select the best equipment to get the most out of your hobby, shows latest SSB, mobile and CB gear.
7. Spells better kit building for experimenters — it contains thousands of useful items not contained in smaller, incomplete catalogs.
8. Short-cuts delivery time — products shown in The MASTER are available from local distributors — just a phone call away.
9. Saves design time — the product you are looking for is illustrated and completely described with specifications and prices.
10. Saves buying time — truly an electronics supermarket, so great a variety, so detailed, you can purchase directly from its pages.
11. Cuts production costs — the widest selection helps you locate standard items that meet your requirements. Eliminates need to order a custom item.
12. Keeps production lines moving — get that much needed product that's holding up production, from your local distributor's stock.
13. Eliminates errors in buying — The MASTER makes an excellent common reference when you are ordering from distributors by phone or mail.
14. Makes it easy to find the product you want immediately — 32 product sections thoroughly indexed makes the world's biggest electronic catalog also the easiest to use.
15. Simplifies foreign tube substitutions — NEW Foreign Tube Interchangeability Guide cross-references virtually all foreign tubes to their European/American and American types. Tells who makes what.

Visit your electronic distributor today and get your copy of the 1963 MASTER. Or, use postage-paid card to order your copy immediately.

The Radio-Electronic MASTER • 645 Stewart Avenue • Garden City, N. Y.

NEW SAMS BOOKS

Color TV Trouble Clues

A "must" for every service technician. Outlines trouble clues and procedures for repair of color TV receivers of all makes—advice and guidance on solving color TV problems which has actually been field-tested. Covers types of troubles encountered, troubleshooting techniques, alignment and sync problems, convergence, etc. Includes valuable section on the use of test equipment to speed color set servicing. Fully illustrated with photographs and schematics; a welcome help and a reference guide for those ever-increasing color TV jobs. 96 pages; 5½ x 8½". Order COL-1, only. \$195

Handbook of Ham Radio Circuits

By David E. Hicks. Contains complete schematic diagrams and definitive descriptions for over 50 of the most popular amateur radio transmitters and receivers. Written for hams and technicians, this book covers the circuitry, operation, general function, and special distinguishing features of each piece of equipment. Excellent for troubleshooting and modification needs, as well as a guide for buying equipment. 128 pages; 8½ x 11". Order HRC-1, only. \$95

Microwave Systems Fundamentals

By F. Jonathan Mivec. This book gives you a clear understanding of microwave applications, including a basic analysis of microwave systems, and detailed explanations of the principles involved. Chapters: Introduction to Microwaves; Behavior of Microwaves; Transmission Systems; Cavity Resonators; Oscillators; Receivers; Antennas; special appendices on Mathematical Construction of a Profile Diagram and Waveguide Mathematics and Equivalent Circuits of an Amplifier and Quartz Crystal. 288 pages; 5½ x 8½". Order MSM-1, only. \$95

BROADCAST ENGINEERING NOTEBOOKS: VOL. 2 AM-FM Broadcast Operations

By Harold E. Ennes. The second volume in this unique series covers technical operations of radio stations from the operator's point of view. Ranges from basic information such as the layout for control rooms to the more complex subjects of remote equipment, etc. Problems encountered and proper procedures for operating both inside and outside the studio are examined. Includes sections on operating the transmitter, and FCC rules. An excellent aid in preparing for FCC license examinations. 256 pages; 5½ x 8½". Order BEN-2, only. \$95

Electronic Tests & Measurements

By Robert G. Middleton. Another practical, authoritative book by a leading expert on measurement procedures and equipment. Takes a new approach by giving the reader a thorough understanding of circuit characteristics, on the sound premise that the theory behind what you are doing is as important as the work itself. Helps you increase your knowledge of circuitry as well as your proficiency in testing. Chapters include: Electrical & Electronic Units; Nonlinear Devices; Transient Analysis; Bridge Measurements; Amplifiers; Electronic Testing Theory; High-Frequency Tests & Measurements. 288 pages; 5½ x 8½"; hardbound. Order MET-1, only. \$95

How to Detect & Measure Radiation

By Harold S. Renne. What is radiation? Where does it come from and how is it detected and measured? These are questions millions of people are asking today. In simple everyday language, this book describes the sources of radiation and how it radiates or "spreads out." Special attention is given to detection and measurement devices and just how they operate. Of special interest to experimenters, technicians, students, Civil Defense personnel, and engineers. 160 pages; 5½ x 8½". Order ADR-2, only. \$95

Hall Effect Instrumentation

By Barron Kemp. An important book on a new and growing field, showing the innumerable applications being found for the Hall effect principle. Unknown 20 years ago, this principle is becoming one of the most effective theories for measurement instrumentation. Here is a full analysis of the Hall effect and its applications. Chapters: The Hall Effect; Multiplier Applications; Wattmeters; Modulators; Constant Control-Current Applications; Displacement Applications; Magneto-resistive Devices; Measuring Magnetic Fields. An invaluable reference and instructive text for engineers and students. 128 pages; 5½ x 8½"; hardbound. Order HAL-1, only. \$495

HOWARD W. SAMS & CO., INC.

Order from your Sams Distributor today, or mail to Howard W. Sams & Co., Inc., Dept. B-23
4300 W. 62nd Street, Indianapolis 6, Ind.

Send me the following books:

COL-1 MSM-1 MET-1 HAL-1
 HRC-1 BEN-2 ADR-2

\$ _____ enclosed. Send FREE Booklist

Name _____

Address _____

City _____ Zone _____ State _____

IN CANADA: A. C. Simmonds & Sons, Ltd., Toronto 7



Third Hand for Soldering

Small-part soldering for experimental work generally requires three hands—one for the iron, one for the part and one for the solder. An alligator clip, a plumber's lead pig and a good banana plug can be very helpful. Remove the sleeve from the plug and insert into a close fit hole in the pig. Swedge or solder in place. Mount the alligator clip on the plug, and you have a third hand!—N. B. Brubaker

Insulating Lugs and Connectors

Building a piece of equipment using terminal strips and spade-lug connectors? Then you've run into the problem of keeping shifting connectors from shorting each other. There is a simple cure. Take a piece of Alphex shrinkable



tubing just large enough to fit over the wide part of the lug. Slip it over the lug and heat it with your soldering iron or over a candle flame until it shrinks down to a tight fit over the lug. Now, when you connect the lug, the insulating coating will be forced back just enough to uncover the part of the lug that goes under the screw; the rest will be completely insulated.—Warren Roy

Helical Potentiometer

With increased interest in the more sophisticated forms of electronic components improved precision in measurements has followed as a natural by-product. Many feel the need of a better variable resistance than the common volume control.



When I reached this stage, I equipped myself with a precision device that has proved invaluable. A helical potentiometer is really just a glorified volume control. It provides better accuracy since it requires 10 full rotations from maximum to minimum resistance, and the resistance element is extremely linear. A good helical pot can be purchased new for about \$10. I mounted my 1,000-ohm helical pot in a meter case, as shown. Since the dial must indicate the number of turns as well as the degree of rotation, a special dial must also be purchased from the manufacturer. Because the linearity of the pot is 0.25%, readings are extremely accurate. Reset accuracy is excellent.

I use the helical pot to substitute for unknown resistors, for voltage-divider applications, grid bias control and special potentiometric voltage measurements.—William E. Bentley

Rubber Bumpers for Rabbit-Ears

The telescoping tips of rabbit-ear TV antennas are a hazard to the eyes of careless children and grownups. If

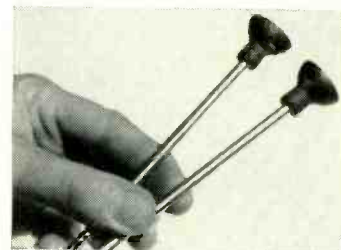

your rabbit-ear antenna is down where it might accidentally poke an eye, attach rubber suction-cup bumpers to the tips. If the cup holes are too large to make a tight fit, fill them with crumpled aluminum foil or wood putty. Better safe than sorry!—Albert Mason

Silicon Rectifier Adapter

Here's a simplification of the low-voltage silicon rectifier adapters described on page 40 of the June 1960 issue.

If one half of the secondary winding of the power transformer has a dc resistance equal to or greater than the value of the surge-limiting resistor,

the surge limiting is taken care of by the transformer, and the resistors are unnecessary.

In almost all instances, the transformer windings will have several times the required resistance.—Roy L. S. Orvis

Pix Tube Jig

When the base pulls away from the neck of a picture tube, I find it easy to line up the lead-in wires with the plug by using the jig shown in the diagram. It is made from a large aluminum wash-

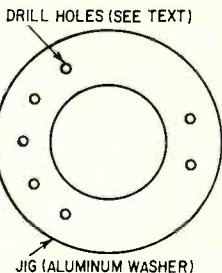

er, using a standard picture-tube socket as a template. The holes are just large enough to admit the leads. After filing and clearing the plug pins, the wires are pushed through the holes, straightened, and the template jig removed. The plug can now be slipped on the wires and soldered.—William A. Bruce

Stop Watch Times Repair

We use a stop watch with a hold-time feature, to price all repair work accurately. Each job is priced to the closest minute, and the watch is stopped when we answer the phone or wait on a customer.

The customer finds this fair and acceptable, especially if he's standing around while we're shooting trouble in his set.

Unlike some shops, we welcome a customer in to watch us work. Most times, when he sees the complexity of his TV chassis and the instruments we use, we have little trouble collecting the fair clocked charge.—H. Josephs END

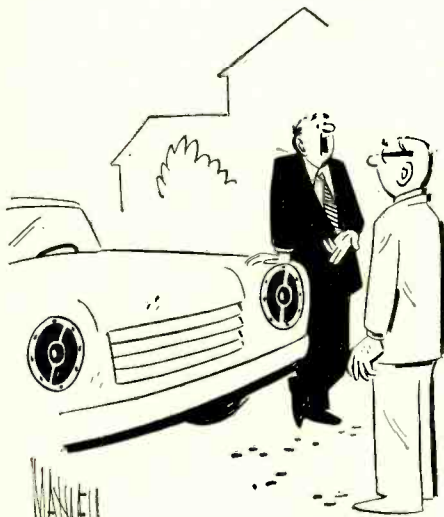

"Stereo."

FEBRUARY, 1963



Get your FREE 1963 CATALOG FROM CONAR

It's full of exciting new electronic kits of highest quality. Many items available in both kit or assembled form. Home entertainment items that make perfect family gifts or test instruments for the technician who appreciates quality and high performance. Tools, too, to make your work easier, faster. And you'll like the reasonable prices and convenient payment plans which make CONAR Kits easy to own. Mail coupon for new 1963 Catalog now.



5-Inch Wide Band Oscilloscope Kit

For black-white, color, AM-FM and electronic applications. High intensity trace. Extremely stable sync. Advanced design. Kit: **\$89.50**
Assembled: **\$139.50**

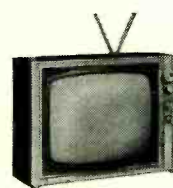

"Custom 70" TV Set Kit

Excellent sensitivity. Transformer power supply; 3 stages of IF. Includes cabinet, 19" tube — everything. NOT a portable. Kit: **\$135.00**

Transistor Radio Kit

Superb tone and sensitivity. No delicate printed circuits. Attractive, durable case. All U.S. made parts. Kit: **\$25.50**



Vacuum Tube Volt Meter Kit (6-Inch Meter)

RMS and p. to p. scale. Input imped. 12.2 megs. Professional performance. Kit: **\$31.95**
Assembled: **\$44.95**



CONAR division of NATIONAL RADIO INSTITUTE
Mail this Coupon

GUARANTEE Parts and performance guaranteed by NRI — nearly 50 years of pioneering in Electronics.	CONAR 3939 Wisconsin Ave., N.W. Washington 16, D.C.	BC-3C
	Send me your new 1963 CONAR KIT CATALOG	
	Name _____	
	Address _____	
	City _____ Zone _____ State _____	

INDUSTRIAL-SPECIAL PURPOSE TUBES TV-RADIO AND HI-FI TUBES

Largest Diversified Stock in U.S.A.

Quality Tubes at savings to distributors, dealers and servicemen. Check with BARRY *first!* Quotations answered same day . . . We also BUY tubes (Name brands, unused only).

Write:

BARRY ELECTRONICS® 512 Broadway, New York 12, N. Y.
Phone: 212-Walker 5-7000

OUR "SENSATIONAL VALUES" ARE NO SECRET!

Last month we sold a 4-Tube Radio for \$1 - - - We sell a \$200 HEARING AID for \$2
Our DOLLAR BUY would be a bargain even at FIVE DOLLARS - - - HOW DO WE DO IT?

Our TREMENDOUS BUYING POWER & PURCHASING EXPERIENCE make it possible. We invest Thousands of Dollars (in just a single item) to create a good DOLLAR BUY, resulting in the AMAZING & EXCITING OFFERS that follow:

10% OFF & FREE GIFT - ON PURCHASE OF \$10 OR OVER

- | | | | |
|-------------------------------------------------------------------------------------------------------------------------------------------------------------------------------------------------------------------------------------------------------------------------------------------------------------------------------------------------------------------------------------------------------------------------------------------------------------------------------------------------------------------------------------------------------------------------------------------------------------------------------------------------------------------------------------------------------------------------------------------------------------------------------------------------------------------------------------------------------------------------------------------------------------------------------------------------------------------------------------------------------------------------------------------------------------------------------------------------------------------------------------------------------------------------------------------------------------------------------------------------------------------------------------------------------------------------------------------------------------------------------------------------------------------------------------------------------------------------------------------------------------------------------------------------------------------------------------------------------------------------------------------------------------------------------------------------------------------------------------------------------------------------------------------------------------------------------------------------------------------------------------------------------------------------------------------------------------------------------------------------------------------------------------------------------------------------------------------------------------------------------------------------------------------------------------------------------------------------------------------------------------------------------------------------------------------------------------------------------------------------------------------------------------------------------------------------------------------------------------------------------------------------------------------------------------------------------------------------------------------------------------------------------------------------------------------------------------------------------------------------------------------------------------------------------------------------------------------------------------------------------------------------------------------------|----------------------------------------------------------------------------------------------------------------------------------------------------------------------------------------------------------------------------------------------------------------------------------------------------------------------------------------------------------------------------------------------------------------------------------------------------------------------------------------------------------------------------------------------------------------------------------------------------------------------------------------------------------------------------------------------------------------------------------------------------------------------------------------------------------------------------------------------------------------------------------------------------------------------------------------------------------------------------------------------------------------------------------------------------------------------------------------------------------------------------------------------------------------------------------------------------------------------------------------------------------------------------------------------------------------------------------------------------------------------------------------------------------------------------------------------------------------------------------------------------------------------------------------------------------------------------------------------------------------------------------------------------------------------------------------------------------------------------------------------------------------------------------------------------------------------------------------------------------------------------------------------------------------------------------------------------------------------------------------------------------------------------------------------------------------------------------------------------------------------------------------------------------------------------------------------------------------------------------------------------------------------------------------------------------------------------------------------------------------------------------------------------------------------------------------------------------------------------------------------------------------------------------------------------------------------------------------------------------------------------------------------------------------------------------------------------------------------------------------------------------------------------------------------------------------------------------------------------------------------------------------------------------------------------|---------------------------------------------------------------------------------------------------------------------------------------------------------------------------------------------------------------------------------------------------------------------------------------------------------------------------------------------------------------------------------------------------------------------------------------------------------------------------------------------------------------------------------------------------------------------------------------------------------------------------------------------------------------------------------------------------------------------------------------------------------------------------------------------------------------------------------------------------------------------------------------------------------------------------------------------------------------------------------------------------------------------------------------------------------------------------------------------------------------------------------------------------------------------------------------------------------------------------------------------------------------------------------------------------------------------------------------------------------------------------------------------------------------------------------------------------------------------------------------------------------------------------------------------------------------------------------------------------------------------------------------------------------------------------------------------------------------------------------------------------------------------------------------------------------------------------------------------------------------------------------------------------------------------------------------------------------------------------------------------------------------------------------------------------------------------------------------------------------------------------------------------------------------------------------------------------------------------------------------------------------------------------------------------------------------------------------------------------------------------------------------------------------------------------------------------------------------------------------------------------------------------------------------------------------------------------------------------------------------------------------------------------------------------------------------------------------------------------------------------------------------------------------------------------------------------------------------------------------------------------------------|-------------------------------------------------------------------------------------------------------------------------------------------------------------------------------------------------------------------------------------------------------------------------------------------------------------------------------------------------------------------------------------------------------------------------------------------------------------------------------------------------------------------------------------------------------------------------------------------------------------------------------------------------------------------------------------------------------------------------------------------------------------------------------------------------------------------------------------------------------------------------------------------------------------------------------------------------------------------------------------------------------------------------------------------------------------------------------------------------------------------------------------------------------------------------------------------------------------------------------------------------------------------------------------------------------------------------------------------------------------------------------------------------------------------------------------------------------------------------------------------------------------------------------------------------------------------------------------------------------------------------------------------------------------------------------------------------------------------------------------------------------------------------------------------------------------------------------------------------------------------------------------------------------------------------------------------------------------------------------------------------------------------------------------------------------------------------------------------------------------------------------------------------------------------------------------------------------------------------------------------------------------------------------------------------------------------------------------------------------------------------------------------------------------------------------------------------------------------------------------------------------------------------------------------------------------------------------------------------------------------------------------------------------------------------------------------------------------------------------------------------------------------------------|
| <ul style="list-style-type: none"> <input type="checkbox"/> 1-EMERGENCY AUTO LAMP \$1
Red dome blinker, Incl Battery <input type="checkbox"/> \$15.00 RADIO PARTS \$1
"JACKPOT" handy assortment <input type="checkbox"/> 1-6" x 9" OVAL PM SPEAKER (one to a customer) \$1 <input type="checkbox"/> 1-5" PM SPEAKER \$1
Alnico #5 magnet <input type="checkbox"/> 1-4" PM SPEAKER \$1
Alnico #5 magnet <input type="checkbox"/> 3-AUDIO OUTPUT TRANSFORMERS 50L6 type \$1 <input type="checkbox"/> 3-AUDIO OUTPUT TRANSFORMERS 6K6 or 6V6 type \$1 <input type="checkbox"/> 3-AUDIO OUTPUT TRANSFORMERS 3Q4, 3Q5, 3S4 \$1 <input type="checkbox"/> 3-I.F. COIL TRANSFORMERS 456kc, most popular type \$1 <input type="checkbox"/> 15-RADIO OSCILLATOR COILS standard 456kc \$1 <input type="checkbox"/> 3-I.F. COIL TRANSFORMERS 10.7mc for FM \$1 <input type="checkbox"/> 2-G.E. #RTL-143 I.F. COIL TRANSFORMERS 456kc w/flange \$1 <input type="checkbox"/> 3-I.F. COIL TRANSFORMERS 262kc for Auto Radios \$1 <input type="checkbox"/> 4-OVAL LOOP ANTENNAS assorted popular sizes \$1 <input type="checkbox"/> 3-LOOPSTICK ANTENNAS hi-gain, ferrite, adjustable \$1 <input type="checkbox"/> 3-1/2 MEG VOLUME CONTROLS with switch \$1 <input type="checkbox"/> 5-ASST. 4 WATT WIRE WOUND CONTROLS \$1 <input type="checkbox"/> 10 - ASSORTED VOLUME CONTROLS less switch \$1 <input type="checkbox"/> 5-ASSORTED VOLUME CONTROLS with switch \$1 <input type="checkbox"/> 5-50K VOLUME CONTROLS less switch \$1 <input type="checkbox"/> 10-250K VOLUME CONTROLS less switch 2" shaft \$1 <input type="checkbox"/> 10-SURE-GRIP ALLIGATOR CLIPS 2" plated \$1 <input type="checkbox"/> 10-SETS PHONO PLUGS & PIN JACKS RCA type \$1 <input type="checkbox"/> 20-ASST. PILOT LIGHTS #44, 46, 47, 51, etc. \$1 <input type="checkbox"/> 20-PILOT LIGHT SOCKETS bayonet type, wired \$1 <input type="checkbox"/> 50-ASSORTED TERMINAL STRIPS 1, 2, 3, 4 lugs \$1 <input type="checkbox"/> 100-FINEST NYLON DIAL CORD best size, .028 gauge \$1 <input type="checkbox"/> 50-ASST. RADIO KNOBS screw and push-on types \$1 <input type="checkbox"/> 25-ASST. CLOCK RADIO KNOBS in colors \$1 <input type="checkbox"/> 25-ASSORTED PRINTED CIRCUIT SOCKETS best types \$1 <input type="checkbox"/> 30-INSTRUMENT POINTER KNOBS popular screw type \$1 <input type="checkbox"/> 10-SPRAGUE CONDENSERS 100/100/10-75 volts \$1 <input type="checkbox"/> 1-LB SPOOL ROSIN-CORE SOLDER 40/60 \$1 <input type="checkbox"/> 20-BALL POINT PENS Retractable, assorted colors \$1 | <ul style="list-style-type: none"> <input type="checkbox"/> 100-ASSORTED 1/2 WATT RESISTORS some in 5% \$1 <input type="checkbox"/> 70 - ASSORTED 1 WATT RESISTORS some in 5% \$1 <input type="checkbox"/> 35 - ASSORTED 2 WATT RESISTORS some in 5% \$1 <input type="checkbox"/> 40-ASST. PRECISION RESISTORS in 1 percenters \$1 <input type="checkbox"/> 20 - ASSTED WIREWOUND RESISTORS 5, 10, 20 watt \$1 <input type="checkbox"/> 10 - ASST. RADIO ELECTROLYTIC CONDENSERS \$1 <input type="checkbox"/> 5-ASST. TV ELECTROLYTIC CONDENSERS \$1 <input type="checkbox"/> 2 - ELECTROLYTIC CONDENSERS 125-140 volts \$1 <input type="checkbox"/> 4 - ELECTROLYTIC CONDENSERS 20/20-450v \$1 <input type="checkbox"/> 300-ASST. 1/2 W RESISTORS AB, IRC, Short leads, excellent \$1 <input type="checkbox"/> 10-6' ELECTRIC LINE CORDS with plug \$1 <input type="checkbox"/> 4-50' SPOOLS HOOK-UP WIRE 4 different colors \$1 <input type="checkbox"/> 50-STRIPS ASSORTED SPAGHETTI handy sizes \$1 <input type="checkbox"/> 100 - ASSORTED RUBBER GROMMETS best sizes \$1 <input type="checkbox"/> 200'-BUSS WIRE #20 tinned for hookups, special circuits, etc. \$1 <input type="checkbox"/> 250-ASST. SOLDERING LUGS best types and sizes \$1 <input type="checkbox"/> 1000-ASST. HARDWARE KIT screws, nuts, washers, rivets, etc. \$1 <input type="checkbox"/> 1000-BRASS SCREWS 3/8" long, flat head \$1 <input type="checkbox"/> 250-ASST. SELF TAPPING SCREWS #6, #8, etc. \$1 <input type="checkbox"/> 150-ASST. 6/32 SCREWS and 150 6/32 HEX NUTS \$1 <input type="checkbox"/> 150-ASST. 8/32 SCREWS and 150-8/32 HEX NUTS \$1 <input type="checkbox"/> 150-6/32 HEX NUTS and 150-8/32 HEX NUTS \$1 <input type="checkbox"/> 8-ASST. LUCITE CASES hinged cover, handy for parts \$1 <input type="checkbox"/> 4-TOGGLE SWITCHES SPST, SPDT, DPST, DPDT \$1 <input type="checkbox"/> 10 - ASSORTED SLIDE SWITCHES SPST, DPDT, etc. \$1 <input type="checkbox"/> 100-ASST RUBBER & FELT FEET FOR CABINETS best sizes \$1 <input type="checkbox"/> 50-100K 1/2 WATT RESISTORS 10% \$1 <input type="checkbox"/> 50-470K 1/2 WATT RESISTORS 10% \$1 <input type="checkbox"/> 50-ASST. MICA CONDENSERS some in 5% \$1 <input type="checkbox"/> 50-ASST. DISC CERAMIC CONDENSERS popular numbers \$1 <input type="checkbox"/> 25-ASSORTED MICA TRIMMER CONDENSERS \$1 <input type="checkbox"/> 3-SELENIUM RECTIFIERS 2-65ma and 1-75ma \$1 <input type="checkbox"/> 2-SELENIUM RECTIFIERS 1-100 ma and 1-250 ma \$1 <input type="checkbox"/> 2-SELENIUM RECTIFIERS 1-65ma and 1-450ma \$1 | <ul style="list-style-type: none"> <input type="checkbox"/> \$15.00 TELEVISION PARTS \$1
"JACKPOT" best buy ever <input type="checkbox"/> 5-NICHROME HEATING COILS 1000 watts \$1 <input type="checkbox"/> 50-ASSORTED TV COILS I.F. video, sound ratio, etc. \$1 <input type="checkbox"/> 1-S10 INDOOR TV ANTENNA hi-gain, 3 section, tiltproof \$1 <input type="checkbox"/> 5-TV CHEATER CORDS with both plugs \$1 <input type="checkbox"/> 3-ELECTROLYTIC CONDENSERS 50/30-150v \$1 <input type="checkbox"/> 100'-TWIN TV LEAD-IN WIRE 300 ohm, heavy duty \$1 <input type="checkbox"/> 50' - FLAT 4-CONDUCTOR WIRE many purposes \$1 <input type="checkbox"/> 40-ASSORTED TV KNOBS ESCUTCHEONS etc. \$20 value \$1 <input type="checkbox"/> 6-ASSORTED STANDARD TUNER UHF STRIPS \$1 <input type="checkbox"/> 1-70° FLYBACK TRANSFORMER Incl. Schematic Diagram \$1 <input type="checkbox"/> 100-ASST. CERAMIC CONDENSERS some in 5% \$1 <input type="checkbox"/> 2-TV VERTICAL OUTPUT TRANSFORMERS 16 to 1 ratio \$1 <input type="checkbox"/> 2-RATIO DETECTOR COILS 4.5mc or 10.7mc \$1 <input type="checkbox"/> 2-TV SOUND I. F. COILS 4.5mc or 21.25 mc \$1 <input type="checkbox"/> 2-SOUND DISCRIMINATOR COILS 4.5mc or 10.7mc \$1 <input type="checkbox"/> 50-ASSORTED TV PEAKING COILS all popular types \$1 <input type="checkbox"/> 4-ASST. TV ION TRAPS for all type TV Receivers \$1 <input type="checkbox"/> 10-TV PICTURE TUBE SOCKETS wired with 20" leads \$1 <input type="checkbox"/> 5-TV HI-VOLT ANODE LEADS 20" length \$1 <input type="checkbox"/> 20-ASSORTED GRID CAPS for 1B3, 1X2, 6BG6, 6BQ6, etc. \$1 <input type="checkbox"/> 10-DIODE CRYSTALS 1N34 \$1 <input type="checkbox"/> 10-ASST. DIODE CRYSTALS 5-1N60 and 5-1N64 \$1 <input type="checkbox"/> 2-SILICON RECTIFIERS 750ma, 400 PIV \$1 <input type="checkbox"/> 3-SILICON RECTIFIERS Top Hat 500ma-400 PIV \$1 <input type="checkbox"/> 50'-INSULATED SHIELDED WIRE #20 braided metal jacket \$1 <input type="checkbox"/> 32'-TEST PROD WIRE deluxe quality, red or black \$1 <input type="checkbox"/> 50'-HI-VOLTAGE WIRE for TV, special circuits, etc. \$1 <input type="checkbox"/> 35-MICA CONDENSERS 20-470mmf and 15-680mmf \$1 <input type="checkbox"/> 35-MICA CONDENSERS 20-2000mmf & 15-2500mmf \$1 <input type="checkbox"/> 35-CERAMIC CONDENSERS 20-250mmf & 15-470mmf \$1 <input type="checkbox"/> STANDARD BRAND TUBES 024, 1B3, 1X2, 5U4, 5Y3, 6AC7, 6AU6, 6AX4, 6CB6, 6CG7, 6J6, 6K6, 6SN7, 6U8, 6X8, 12AT7, 12AU7, 12AX4, 50C5, 50L6 Each Tube \$1 | <h3>MARKET SCOOP COLUMN</h3> <ul style="list-style-type: none"> <input type="checkbox"/> 500' CHOICE HOOKUP WIRE \$1
assst colors cut in handy lengths some stripped & tinned <input type="checkbox"/> 1-SQ. YARD GRILLE CLOTH \$1
most popular brown & gold design <input type="checkbox"/> 10-ASSORTED TUBES \$1
Radio, Television and Industrial <input type="checkbox"/> 6-TRANS. RADIO BATTERIES \$1
9 volt, same as Eveready #216 <input type="checkbox"/> 20-ASST. ROTARY SWITCHES \$1
all popular types over \$20 value <input type="checkbox"/> 20-ASST. DIODE CRYSTALS \$1
fine assortment, Latest types <input type="checkbox"/> 100-CERAMIC CONDENSERS \$1
300 mmf, 500 volts <input type="checkbox"/> 2-WIRE STRIPPERS/CUTTERS \$1
adjust to all insulation sizes <input type="checkbox"/> 50-RCA PHONO PLUGS \$1
Standard for phonos, male <input type="checkbox"/> 10-SILICON RECTIFIERS \$1
Top hat, 350 ma, 200 piv <input type="checkbox"/> 3-3" RECORDER TAPES \$1
Quality acetate, 150 feet <input type="checkbox"/> 20-G-E #NE-2 TUBES \$1
Neon Glow Lamp for 101 uses <input type="checkbox"/> 10-KENRAD 65H7 TUBES \$1 <input type="checkbox"/> 10-1/2 MEG VOL CONTROLS \$1 <input type="checkbox"/> 6-TV ALIGNMENT TOOLS \$1 <input type="checkbox"/> 10-RCA #12L8 TUBES \$1 <input type="checkbox"/> 10-RCA #954 TUBES \$1 <input type="checkbox"/> 10-ROGERS #2X2 TUBES \$1 <input type="checkbox"/> 3-SYLVANIA 35W4 TUBES \$1 <input type="checkbox"/> 10-AMPERITE #3-38 TUBES \$1
most popular Ballast Tube <input type="checkbox"/> 6-I.F. COIL TRANSFORMERS \$1
456 kc, latest 3/4" x 3/4" type <input type="checkbox"/> 1-90° FLYBACK TRANSFORM. \$1
ER including schematic diagram <input type="checkbox"/> 1-HEARING AID AMPLIFIER \$1
incl 3 Tubes, Mike, Etc (as is) <input type="checkbox"/> 100-ASSORTED SOCKETS \$1
all type 7 pin, 8 pin, 9 pin <input type="checkbox"/> 100-ASSORTED FUSES \$1
3AG and other popular sizes <input type="checkbox"/> 100-ASSORTED TUBULAR CONDENSERS .001 to .47 up to 600v \$1 <input type="checkbox"/> 20-STANDARD CONDENS. \$1
ERS .047-600v 85° top quality <input type="checkbox"/> 10-C-D TUBULAR CONDENS. \$1
ERS 50mfd-200 volts lists at \$1 <input type="checkbox"/> 1-CHAPT ZU DI MITZIA \$1
"JACKPOT" limited supply <input type="checkbox"/> 1-4 SPEED PHONO ARM \$2
with sapphire flipover Cartridge |
|-------------------------------------------------------------------------------------------------------------------------------------------------------------------------------------------------------------------------------------------------------------------------------------------------------------------------------------------------------------------------------------------------------------------------------------------------------------------------------------------------------------------------------------------------------------------------------------------------------------------------------------------------------------------------------------------------------------------------------------------------------------------------------------------------------------------------------------------------------------------------------------------------------------------------------------------------------------------------------------------------------------------------------------------------------------------------------------------------------------------------------------------------------------------------------------------------------------------------------------------------------------------------------------------------------------------------------------------------------------------------------------------------------------------------------------------------------------------------------------------------------------------------------------------------------------------------------------------------------------------------------------------------------------------------------------------------------------------------------------------------------------------------------------------------------------------------------------------------------------------------------------------------------------------------------------------------------------------------------------------------------------------------------------------------------------------------------------------------------------------------------------------------------------------------------------------------------------------------------------------------------------------------------------------------------------------------------------------------------------------------------------------------------------------------------------------------------------------------------------------------------------------------------------------------------------------------------------------------------------------------------------------------------------------------------------------------------------------------------------------------------------------------------------------------------------------------------------------------------------------------------------------------------------------------|----------------------------------------------------------------------------------------------------------------------------------------------------------------------------------------------------------------------------------------------------------------------------------------------------------------------------------------------------------------------------------------------------------------------------------------------------------------------------------------------------------------------------------------------------------------------------------------------------------------------------------------------------------------------------------------------------------------------------------------------------------------------------------------------------------------------------------------------------------------------------------------------------------------------------------------------------------------------------------------------------------------------------------------------------------------------------------------------------------------------------------------------------------------------------------------------------------------------------------------------------------------------------------------------------------------------------------------------------------------------------------------------------------------------------------------------------------------------------------------------------------------------------------------------------------------------------------------------------------------------------------------------------------------------------------------------------------------------------------------------------------------------------------------------------------------------------------------------------------------------------------------------------------------------------------------------------------------------------------------------------------------------------------------------------------------------------------------------------------------------------------------------------------------------------------------------------------------------------------------------------------------------------------------------------------------------------------------------------------------------------------------------------------------------------------------------------------------------------------------------------------------------------------------------------------------------------------------------------------------------------------------------------------------------------------------------------------------------------------------------------------------------------------------------------------------------------------------------------------------------------------------------------------------------------|---------------------------------------------------------------------------------------------------------------------------------------------------------------------------------------------------------------------------------------------------------------------------------------------------------------------------------------------------------------------------------------------------------------------------------------------------------------------------------------------------------------------------------------------------------------------------------------------------------------------------------------------------------------------------------------------------------------------------------------------------------------------------------------------------------------------------------------------------------------------------------------------------------------------------------------------------------------------------------------------------------------------------------------------------------------------------------------------------------------------------------------------------------------------------------------------------------------------------------------------------------------------------------------------------------------------------------------------------------------------------------------------------------------------------------------------------------------------------------------------------------------------------------------------------------------------------------------------------------------------------------------------------------------------------------------------------------------------------------------------------------------------------------------------------------------------------------------------------------------------------------------------------------------------------------------------------------------------------------------------------------------------------------------------------------------------------------------------------------------------------------------------------------------------------------------------------------------------------------------------------------------------------------------------------------------------------------------------------------------------------------------------------------------------------------------------------------------------------------------------------------------------------------------------------------------------------------------------------------------------------------------------------------------------------------------------------------------------------------------------------------------------------------------------------------------------------------------------------------------------------------------|-------------------------------------------------------------------------------------------------------------------------------------------------------------------------------------------------------------------------------------------------------------------------------------------------------------------------------------------------------------------------------------------------------------------------------------------------------------------------------------------------------------------------------------------------------------------------------------------------------------------------------------------------------------------------------------------------------------------------------------------------------------------------------------------------------------------------------------------------------------------------------------------------------------------------------------------------------------------------------------------------------------------------------------------------------------------------------------------------------------------------------------------------------------------------------------------------------------------------------------------------------------------------------------------------------------------------------------------------------------------------------------------------------------------------------------------------------------------------------------------------------------------------------------------------------------------------------------------------------------------------------------------------------------------------------------------------------------------------------------------------------------------------------------------------------------------------------------------------------------------------------------------------------------------------------------------------------------------------------------------------------------------------------------------------------------------------------------------------------------------------------------------------------------------------------------------------------------------------------------------------------------------------------------------------------------------------------------------------------------------------------------------------------------------------------------------------------------------------------------------------------------------------------------------------------------------------------------------------------------------------------------------------------------------------------------------------------------------------------------------------------------------------------|

In order to SELL, we must first BUY and that we do on a BIG SCALE. If you have any TUBES, CONDENSERS, RESISTORS or any other PARTS in quantity and new that you wish to sell... please send us samples... We pay SPOT CASH.

HANDY WAY TO ORDER - Simply pencil mark items wanted in squares and enclose with money order or check... You will receive a new copy of these Offers for re-orders. ON SMALL ORDERS - Include stamps for postage, excess refunded - - - LARGER ORDERS shipped express charges collect SAME DAY DELIVERY... SCIENTIFIC PACKING for minimum shipping cost.

BROOKS RADIO & TV CORP., 84 Vesey St., Dept. A, New York 7, N. Y. TELEPHONE
C.Orland 7-2359

NOTEWORTHY CIRCUITS

Protect Your Transistors!

While experimenting with power transistors such as the 2N227 which have a punch-through voltage of 80 or more, install a small NE-2 neon lamp between the collector and emitter (Fig. 1). As soon as the voltage reaches 70, the neon lamp will flash

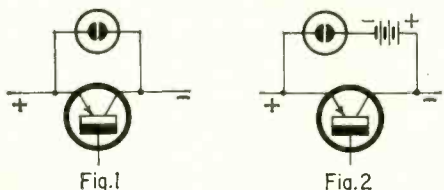

and indicate the danger. Even small rf spikes will be indicated immediately, yet the neon lamp will not affect the circuit when not lighted.

Lower-voltage transistors can be similarly protected by using a small battery in series with the neon lamp (Fig. 2). For a 20-volt transistor, use a 45-volt battery; for a 50-volt transistor, a 22-volt battery, and so on.—Tom Jaski

Electric Combination Lock

This simple electric combination lock is practically tamperproof. You must dial three three-digit numbers in correct sequence to open it. Fumbling will get you nowhere. The lock uses three single-pole 12-position rotary switches, two 500-ohm relays with two sets of make-before-break contacts and two sets of normally open contacts, and a dc solenoid to operate the lock's bolt.

To open the lock, set the switches

FREE GIANT ALL NEW 1963 BA CATALOG



100'S OF NEW ITEMS LISTED HERE FOR 1st TIME

RUSH COUPON TODAY!

BURSTEIN-APPLEBEE CO. Dept. RE,
1012-14 McGee St., Kansas City 6, Mo.

Rush me New 1963 B-A Catalog No. 631.

NAME _____

ADDRESS _____

CITY _____ STATE _____

HOTTEST VALUE EVER OFFERED!

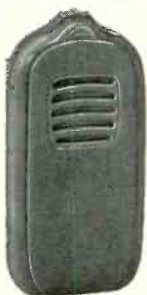

\$200 HEARING AID (as shown)—Your Price . . . \$2

We Scooped the Market on 15000 of these HEARING AIDS from one of the Leading Manufacturers (name withheld) who switched to the Transistor Type.

Each HEARING AID INSTRUMENT is a Complete AUDIO AMPLIFIER and includes—a CRYSTAL MICROPHONE, 3 SUB-MINIATURE TUBES and a Superb Beige Phenolic CABINET.

Indeed a TOP ITEM for the Experimenter—can be modified and converted to: RADIOS—INTERCOMS—TRANSMITTERS—SECRET LISTENING DEVICES — MICROPHONE for Tape Recorders — PRE-AMP & MICROPHONE COMBINATION for Public Address Systems—ETC.

5" x 2½" x 1"—Shipping Weight 1 lb.

Complete as illustrated—Including a detailed informative SCHEMATIC DIAGRAM (less Earphone and Battery) **\$2**

Sold without limit or reserve! Order as many as you want! Rush your order!

BROOKS RADIO & TV 84 Vesey St., New York 7, N. Y.

CONVERT TO COLOR TV

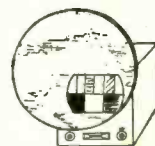

COLORDAPTOR—A simple 10-tube circuit and rotating color wheel converts any size B & W TV to receive compatible color.

COLORDAPTOR — Easily attached to any TV set, does not affect normal operation, often built from parts experimenters have on hand, **BRILLIANT COLOR!**

Complete booklet—gives theory of operation, all construction details, schematic, and sample color filters. **\$195**

Essential Parts Kit—Includes all special parts—coils, delay line, crystal, color filters. Add \$1.00 for sets over 18". **\$19.95**

COLORDAPTOR 1798 Santa Cruz, Menlo Park, Calif.

ARE YOU GETTING THE MOST VALUE FROM YOUR MEASUREMENT DOLLAR? ... Compare all

features and you'll agree, BEST BUY IS EMC!

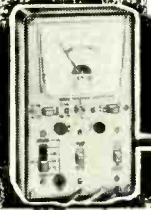

EMC'S NEW MODEL 212 TRANSISTOR ANALYZER ... Checks DC current gain in 3 ranges to 200. Tests for leakage. Checks all transistors as oscillators both in and out of circuit. Can be used to signal trace AF, IF or RF circuits. Checks condition of diodes. Tests battery voltage on 0-12 scale. Checks DC current drain on 0-80 ma scale. Supplied with complete instruction manual, transistor listing and pair of test leads. Model 212 \$18.50 Wired

Model 212 Kit \$13.50



EMC'S NEW MODEL 213 TUBE TESTER ... Completely modern! Completely flexible! Completely new! Checks all the new 12 prong (Compactron),

Nuvistor, Novar, and 10 prong tubes. In addition to octal, loctal, miniature, and 9 prong tubes. Tests each tube for shorts, leakages, intermittents, opens, as well as for quality. Each section of multi-purpose tube is checked separately. Magic eye, Voltage Regulator and Hi-Fi tubes are also tested. Unique switching arrangement makes the checker obsolescent proof. Supplementary tube listings supplied periodically at no cost to keep instrument up to date. It comes complete with instructions and tube charts in ring bound manual.

Model 213 (in bakelite case with strap)

\$28.50 Wired Model 213 Kit \$18.90

Model 213P (in wood carrying case)

\$32.25 Wired Model 213P Kit \$21.90



mutual conductance type.

Model SA \$9.45 Wired Model SA Kit \$4.95

Yes, tell me more, send me FREE a detailed catalog of the Complete EMC Line. Dept. RE-263

NAME _____
STREET _____
CITY _____ STATE _____

EMC Electronic Measurements Corp.
625 B'way, New York 12, N. Y.
Ex. Dept., Pan-Mar Corp., 1270 B'way, New York 1, N. Y.

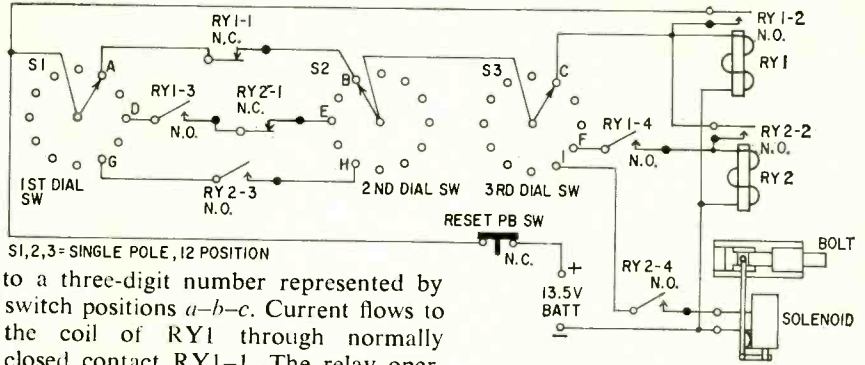

S1,2,3 = SINGLE POLE, 12 POSITION
to a three-digit number represented by switch positions *a-b-c*. Current flows to the coil of RY1 through normally closed contact RY1-1. The relay operates and locks in through contact RY1-2. Normally open contacts RY1-3 and RY1-4 close as RY1-1 opens. RY1-2 must close before RY1-1 opens.

Dialing the second three-digit number (*d-e-f*) energizes RY2's coil through contacts RY1-3, RY2-1 and RY1-4. This relay locks in through RY2-2. At the same time, RY2-1 opens and RY2-3 and RY2-4 close.

Dialing the third number (*g-h-i*) completes the circuit to the solenoid through RY2-3 and RY2-4 and unlocks the door. The RESET switch is used to break the circuit momentarily and release the relays. It may be a normally open snapaction switch recessed into the door jamb. The switch opens and de-energizes the relays when the door opens.

In practice, the solenoid can be replaced by a relay that applies voltage to a standard electric door lock like those used on entrance doors in some apartment buildings.

Analyzing the lock's operation, you will see that the three three-digit numbers must be dialed in correct sequence. If the second number is dialed first, RY2 cannot operate because RY1-3 is open. Likewise, if the third number is dialed out of order, the solenoid cannot operate because RY2-4 is still open.

In the original article in *Wireless World*, the author shows how an alarm can be connected so it sounds when numbers are dialed at random and describes how a second set of three switches can be interconnected with the first set to provide additional protection.

Modified Commercial Killer

While constructing a commercial killer ("Speech-Music Discriminator," *RADIO-ELECTRONICS*, September 1956) I decided to simplify the control circuit by using a transistor.

As originally designed, the killer delivered a -75-volt bias during speech commercials. This could either be trickled through a large resistor and used to cut off an audio voltage amplifier or else made to operate a tube-controlled relay. I decided against the cutoff method for fear of introducing either hum or high-frequency losses at a high-imped-

ance grid. The tube-plus-relay idea was equally unattractive. It needed a dual triode, six resistors, a capacitor, assorted hardware and 300 ma of heater current to do a job that could be handled just as well by one transistor.

The stage shown was built with parts on hand. The 2,000-ohm relay needed 6 volts dc at 3 ma. I used a crystal diode to rectify a portion of 6.3-volt heater supply. Any p-n-p transistor

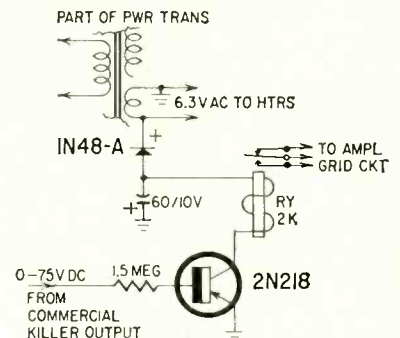

which has enough collector-current capacity would probably work. The 1.5-meg resistor is selected by experiment to suit the transistor and the control voltage. Start with several megohms and reduce the value until the relay closes.

To make a positive signal operate a relay, use an n-p-n transistor and reverse the polarity of the diode and the filter capacitor. If your relay doesn't need 6 volts, ground the heater center tap and take 3 volts off one leg.—Hugh Kenner

END



Suggested by Jerry Filipek

"It has hi-fi sound, a locked-in picture, and also whitewall tires."



Goodwill Service

Just before our warranty expires on a repair or component we've installed, we send a card to the customer calling attention to the deadline and inviting him to call within a week if he has any complaints on his TV, radio, record player, etc. We offer to check and adjust it for free if he can bring the unit in or our technicians can catch it on their rounds.

The card shows we have confidence in our work and our products. On top of that the customer can't come back and gripe later that something was needed right along, because we've given him the opportunity to holler before our guarantee expired.

As to getting loaded up with free work, it doesn't work that way at all. Sure, we get a few kickers; but we also have people who stop by to thank us and this, in turn, often generates new business.—Stanley Clark

P.I.C. Electric Counters

When these counters fail to operate, don't scrap them without a check. Many times a simple repair job will restore proper operation. The counter is actuated by a solenoid which moves the counter one count each time a pulse of

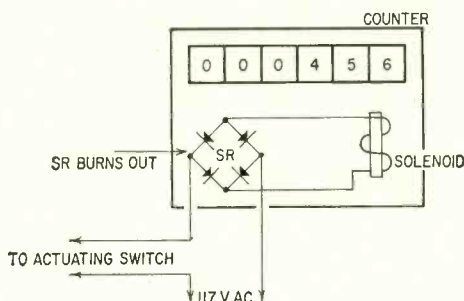

current is switched to the solenoid. While external circuitry is 117 volts ac, the counter has an internal full-wave selenium rectifier which supplies dc to the solenoid. This bridge occasionally burns out and must be changed. The replacement unit is easily installed. Use Seletron model 16J4 or equivalent.—F. G. Lewis

Philco F-3041 Portable

The picture shrank and bloomed in perfect sync with peaks in the sound. Investigation disclosed a big, fat, blue spark in the 12CA5 audio tube each time the picture jumped. The tube was very gassy and peaks in the audio made it fire like a thyratron. This dropped the 135-volt line, the horizontal oscillator plate voltage, etc. Picture size changed whenever the tube fired.—Jack Darr

Motorola 56CD Radio

A customer brought this small table model in for repair and merely said that the radio was dead. After it was fired up, we found that, instead of being dead, it was intermittent. When the radio played, all tubes were lit; when it stopped, the 35W4 heater was real bright, while the rest of the tubes were out.

If the short lasted too long, the 35W4 would pop. Another rectifier tube was plugged into the socket and the
(Continued on page 104)

FEBRUARY, 1963

Euphonics

Orbit Action

CERAMIC CARTRIDGES

REPLACE ALL STEREO AND MONAURAL CARTRIDGES EASIEST OF ALL CARTRIDGES TO INSTALL

No. 1 choice of phono manufacturers. Now, your most logical choice for exact replacement

New Euphonics Orbit Action Cartridges are exact replacements for millions of Euphonics Cartridges now in use, and all other ceramic cartridges. Rugged, trouble-free and easiest to install, Euphonics cartridges offer you these important advantages:

EXCLUSIVE ORBIT ACTION

- Eliminates twisting of lead wires
- Reduces mass of playing needle
- Simplified needle replacement
- Positive tip rake angle—no dirt collecting "hook"
- Provides same wide-range response from both needles: 16-25,000 cps.

Other Advantages: Unique mounting bracket permits fast, snap-in installation of cartridge • Low tracking force (2 grams) for minimum record and stylus wear • Stylus automatically retracts when arm is dropped • PZT ceramic elements eliminate magnetic hum and are impervious to heat and moisture • High compliance: 4 micro-cm per dyne • 4 terminals—complete with jumper for 3-terminal installation.

Complete with dual needles.

- U-8. .0007 Sapphire and .003 Sapphire
- U-9. .0007 Diamond and .003 Sapphire

ALL PRODUCTS AMERICAN MADE



For complete details see your distributor or write Dept.

Euphonics
CORPORATION

GUAYNABO, PUERTO RICO, U.S.A.

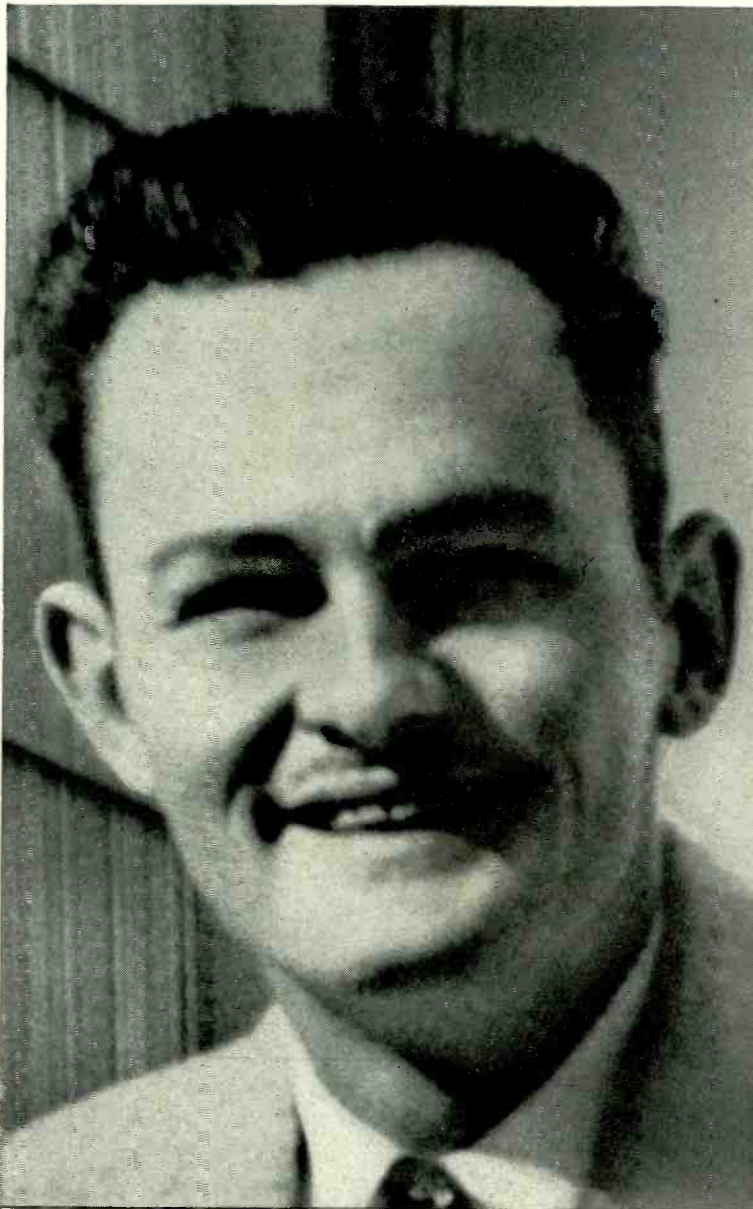

"My income since I started with RCA Institutes has been more than doubled!"

"I now hold a highly interesting job with a promising future as an electronic technician, thanks to RCA Home Training. Might I also state that if it were not for RCA's liberal tuition plan that I would have found things much more difficult, or perhaps impossible."

Dennis R. Crop, Forest Grove, Ore.,
former farm hand, now Electronic Technician
(June, 1962)

"RCA Home Training has given me the necessary background to pass the required tests for my present position."

"You are to be commended on the excellent content and study material of your courses. By going into electronic theory a little bit 'deeper', your Electronics Fundamentals Course far exceeds many other courses that try to cram too many different phases of electronics into one short course."

Robert David Regina, Marienville, Pa., (July, 1962)
former mechanic, now Test Maintenance Technician



"I Began Servicing radio and TV sets after four weeks of your Home Training Course."

"I selected RCA Training after investigating other popular courses and found them inadequate. I believe RCA Home Training is the most informative and most advanced course in the home study field . . . The whole thing from beginning to end is laid out clearly and in a fascinating manner and is so interesting that I was always eager to try the next step . . ."

Clarence Reneau, Dandridge, Tenn., (June, 1962)
former electrician, now self-employed Radio-TV Technician

Actual statements made by RCA Institutes graduates.

RCA Home Training can start you on an Electronics Career now!

RCA INSTITUTES, INC. Dept. ZRE-23

A Service of Radio Corporation of America,
350 West 4th St., New York 14, N. Y.
Pacific Electric Bldg., 610 S. Main St.,
Los Angeles 14, Calif.



**The Most Trusted Name
in Electronics**

The dramatic success stories reported here are just a few of the many actual case histories on file at RCA Institutes, proving that the world of electronics offers you one of the fastest ways to a profitable career and a secure future. Today, more than ever before, RCA Institutes Home Training can be your key to a successful tomorrow.

COMPLETE SELECTION OF HOME TRAINING COURSES. RCA gives you a wide selection of electronics courses to choose from, including:

- Electronic Fundamentals
- TV Servicing
- Color TV
- Communications Electronics
- Automation Electronics
- Computer Programming
- Transistors
- Electronic Drafting

You get prime quality equipment to keep and use on the job, and all kits furnished are complete in every respect.

LIBERAL TUITION PLAN. In addition, RCA has the most liberal tuition plan; you pay only for lessons as you order them and have no long term obligations. Investigate this great opportunity now—from RCA—the name that means dependability, integrity, and scientific advance. Take the step that can mean a successful career now! Send for the free RCA Home Training catalog!

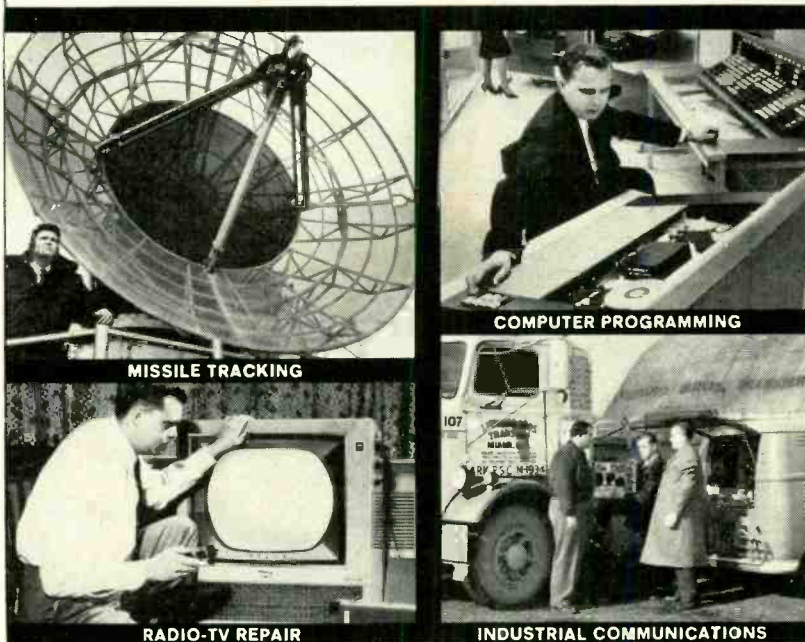

CLASSROOM TRAINING. No previous technical training required for admission. You are eligible even if you haven't completed High School.

RCA also offers you classroom training of the highest caliber if you prefer to build your electronics career at one of the convenient locations throughout the country. At RCA Institutes, Inc., Resident Schools in New York City and Los Angeles, and at RCA Technical Institute in Cherry Hill near Camden, N. J., you can prepare for a rewarding position in the exciting field of electronics.

Coeducational Day and Evening Courses are available. You can prepare for a profitable career in electronics while continuing with your

normal full-time or part-time employment. Classes start at regular intervals throughout the year.

FREE PLACEMENT SERVICE. RCA graduates may take advantage of the free placement service offered to them. A recent Resident School class had 92% of the graduates who used the FREE Placement Service accepted by important electronic companies . . . and had one or more jobs waiting for them on the day they graduated.

Check "Classroom Training" and information will be rushed to you.

**SEND ATTACHED PRE-PAID
POSTCARD FOR FREE
ILLUSTRATED BOOK TODAY!
SPECIFY HOME TRAINING
OR CLASSROOM TRAINING!**



BECOME A RADIO TECHNICIAN

for only \$26.95

BUILD 20 RADIO

CIRCUITS AT HOME

with the New Progressive

RADIO "EDU-KIT"®

All Guaranteed to Work!

PRACTICAL

only

HOME
RADIO
COURSE

\$26.95



Reg. U.S.
Pat. Off.

NOW INCLUDES

- ★ 12 RECEIVERS
- ★ 3 TRANSMITTERS
- ★ SQ. WAVE GENERATOR
- ★ AMPLIFIER
- ★ SIGNAL TRACER
- ★ SIGNAL INJECTOR
- ★ CODE OSCILLATOR

TRAINING ELECTRONICS
TECHNICIANS SINCE 1946

- ★ No Knowledge of Radio Necessary
- ★ No Additional Parts or Tools needed
- ★ Excellent Background for TV
- ★ School Inquiries Invited
- ★ Attractively Gift Packed

FREE EXTRAS

- SET OF TOOLS • RADIO & ELECTRONICS TESTER • ELECTRIC SOLDERING IRON • TESTER INSTRUCTION MANUAL • MEMBERSHIP IN RADIO-TV CLUB: CONSULTATION SERVICE • HI-FI GUIDE • QUIZZES • TV BOOK • FCC AMATEUR LICENSE TRAINING • RADIO BOOK • PRINTED CIRCUITRY • PLIERS-CUTTERS • ALIGNMENT TOOL • WRENCH SET • CERTIFICATE OF MERIT • VALUABLE DISCOUNT CARD

WHAT THE "EDU-KIT" OFFERS YOU

The "Edu-Kit" offers you an outstanding PRACTICAL HOME RADIO COURSE at a rock-bottom price. Our kit is designed to train Radio & Electronics Technicians, making use of the most modern methods of home training. You will learn radio theory, construction, servicing, basic Hi-Fi and TV repairs, code, FCC amateur license requirements.

You will learn how to identify radio symbols, how to read and interpret schematics, how to mount and lay out radio parts, how to wire and solder, how to operate electronic equipment, how to build radios. Today it is no longer necessary to spend hundreds of dollars for a radio course. You will receive a basic education in radio, worth many times the small price you pay, only \$26.95 complete.

THE KIT FOR EVERYONE

The Progressive Radio "Edu-Kit" was specifically prepared for any person who has a desire to learn Radio. The "Edu-Kit" has been used successfully by young and old in all parts of the world by many Radio Schools and Clubs in this country and abroad. It is used for training and rehabilitation of Armed Forces Personnel and Veterans throughout the world.

The Progressive Radio "Edu-Kit" requires no instructor. All instructions are included. Every step is carefully explained. You cannot make a mistake.

PROGRESSIVE TEACHING METHOD

The Progressive Radio "Edu-Kit" is the foremost educational radio kit in the world, and is universally accepted as the standard in the field of electronics training. The "Edu-Kit" uses the modern educational principle of "learn by doing". Therefore, you will construct radio circuits, perform jobs and conduct experiments to illustrate the principles which you learn.

You begin by examining the various radio parts included in the "Edu-Kit." You then learn the function, theory and wiring of these parts. Then you build a simple radio. With this first set, you will enjoy listening to regular broadcast stations, learn theory, practice testing and troubleshooting. Then you build a more advanced radio, learn more advanced theory and techniques. Gradually, in a progressive manner, and at your own rate, you will find yourself constructing more advanced multi-tube radio circuits, and doing work like a professional Radio Technician.

Included in the "Edu-Kit" course are twenty Receiver, Transmitter, Code Oscillator, Signal Tracer, Signal Injector, Square Wave Generator and Amplifier circuits. These are not unprofessional "breadboard" experiments, but genuine radio circuits, constructed by means of professional wiring and soldering on metal chassis, plus the new method of radio construction known as "Printed Circuitry." These circuits operate on your regular AC or DC house current.

In order to provide a thorough, well-integrated and easily-learned radio course, the "Edu-Kit" includes practical work as well as theory; troubleshooting in addition to construction; training for all, whether your purpose in learning radio be for hobby, business or job; progressively-arranged material, ranging from simple circuits to well-developed topics in Hi-Fi and TV. Your studies will be further aided by Quiz materials and our well-known FREE Consultation Service.

THE "EDU-KIT" IS COMPLETE

You will receive all parts and instructions necessary to build 20 different radio and electronics circuits, each guaranteed to operate. Our Kits contain tubes, tube sockets, variable electrolytic, mica, ceramic and paper dielectric condensers, resistors, tie strips, coils, hardware, tubing, punched metal chassis, Instruction Manuals, hookup wire, solder, selenium rectifiers, volume controls, switches, knobs, etc. In addition, you receive Printed Circuit materials, including Printed Circuit chassis, special tube sockets, hardware and instructions. You also receive a useful set of tools, a professional electric soldering iron, and a self-powered Dynamic Radio & Electronics Tester. The "Edu-Kit" also includes Code Instructions and the Progressive Code Oscillator, in addition to the F.C.C.-type Questions and Answers for Radio Amateur License training. You will also receive lessons for servicing with the Progressive Signal Tracer and the Progressive Signal Injector, and a High Fidelity Guide and Quiz Book. Everything is yours to keep.

J. Statatis, of 25 Poplar Pl., Waterbury, Conn., writes: "I have repaired several sets for my friends, and made money. The "Edu-Kit" paid for itself. I was ready to spend \$40 for a course, but I found your ad and sent for your Kit."

UNCONDITIONAL MONEY-BACK GUARANTEE

The Progressive Radio "Edu-Kit" has been sold to many thousands of individuals, schools and organizations, public and private, throughout the world. It is recognized internationally as the ideal radio course.

By popular demand the Progressive Radio "Edu-Kit" is now available in Spanish as well as English.

It is understood and agreed that should the Progressive Radio "Edu-Kit" be returned to Progressive "Edu-Kits" Inc., for any reason whatever, the purchase price will be refunded in full, without quibble or question, and without delay.

The high recognition which Progressive "Edu-Kits" Inc. has earned through its many years of service to the public is due to its unconditional insistence upon the maintenance of perfect engineering, the highest instructional standards, and 100% adherence to its Unconditional Money-Back Guarantee. As a result, we do not have a single dissatisfied customer throughout the entire world.

ORDER FROM AD—RECEIVE FREE BONUS RESISTOR AND CONDENSER KITS WORTH \$7.00

- Send "Edu-Kit" Postpaid. I enclose full payment of \$26.95.
- Send "Edu-Kit" C.O.D. I will pay \$26.95 plus postage.
- Send me FREE additional information describing "Edu-Kit."

Name _____
Address _____

Progressive "EDU-KITS" Inc.

1186 Broadway, Dept. 205G
Hewlett, N. Y.

(Continued from page 99)

radio took off. Again it went dead, but the 35W4 stayed lit for quite a while until the trouble was found. A capacitor from plate to cathode of the 50C5 would short out, drawing

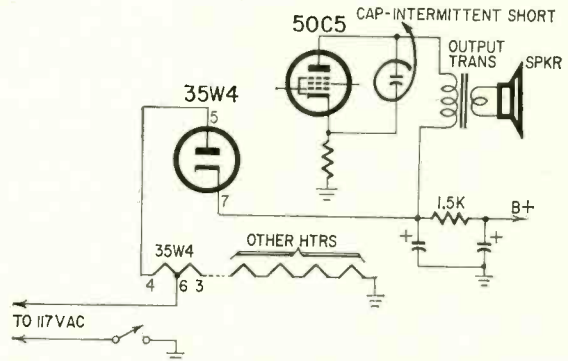

excessive current through the output transformer. Since the heater and plate pin 5 were wired together, half the heater would open, popping the 35W4 when the capacitor shorted.

—Homer L. Davidson

Increase TV Picture Width

Here are a few simple methods that will increase raster width when nothing else seems to work:

1. Decrease the size of the horizontal output tube's cathode bias resistor.
2. Increase the screen voltage on the horizontal output tube. Use some discretion when trying 1 or 2. Too drastic a change may exceed current-handling capabilities of the horizontal output tube and associated circuitry.
3. Shunt the width coil with a 600-volt capacitor (100 pf to .05 μf) or shunt a small number of turns on the horizontal output transformer with a capacitor within the same range. If the capacitor used is too large, you'll get a noticeable foldover on the left side of the raster. For this reason, use as small a value of capacitance as possible.
4. If the width coil is shunting part of the turns on the horizontal output transformer, rewire it so that it shunts a fewer number of turns, if possible.
5. Replace the width coil with another of greater inductance. Again, you may get noticeable foldover if the alterations are too great.

These methods should not be used to increase the size of the raster more than 1/2 inch.—James A. Koepke END



"Why are you complaining you're not busy? Here's one call from your Aunt Mae; here's one from your sister Fran; here's another one from your mother, and here's . . ."

NEW PRODUCTS

HEART-SOUND MIKE, model SP-5 (illus). Detects heart and other sound vibrations in human and animal tissue. Direct-coupled controlled magnetic transducer. Used with standard medical phonocardiograph equipment. Vibrations detected may be transmitted through loudspeakers, earphones, oscilloscopes, graph recorders; pre-

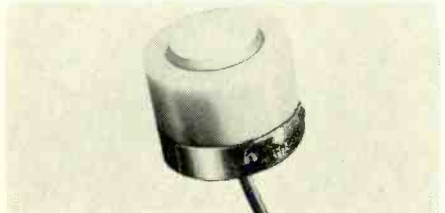

served on magnetic tape with standard tape recorder. Model SP-5S straps to patient for hands-free operation. Model SP-6 for mass survey work with unit mounted to chair.—Medical Applications Engineering Dept., Shure Bros. Inc., 222 Hartrey Ave., Evanston, Ill.

SOLID-STATE DC POWER SUPPLY, Series AD. Supplied with modular remote sensing regulator to maintain regulation without regard to load resistance. Each of 3 available units has 2 matching separable regulators with adjustable output and remote sensing feature. Regulation instantly changeable from standard $\pm 1.0\%$ to $\pm 0.25\%$ or $\pm 0.05\%$. No wiring changes or removal



of supply from mounting, no external heat sink, fans or blowers needed. Supply 6.3, 12 or 28 vdc at 2 amps from 95- to 130-volt 60-cycle source. Overload and short-circuit protected outputs. Output regulation $\pm 1\%$ for line; output ripple 1% rms. Output voltage at full load, accurate to $\pm 5\%$ of nominal. Operating temperature range -20°C to 50°C .—Victory Electronics, Inc., 145 Michael Dr., Syosset, N. Y.

TRANSISTOR REGULATED POWER SUPPLY, model RPS-4. For transistor and tunnel diode operations. 0-28 volts, constant voltage within 3% at 50 ma, within 5% at 100 ma. Meter and output ranges: 0-1 $\frac{1}{2}$, 0-15, 0-30 volts; 0-30, 0-150 ma. Special tap for simultaneous bias collector supply. Overload protection circuit permits feeding into full short. Maximum ripple .001% at full load, output impedance 1.4 ohms. Metered varia-



ble dc supply for transistorized equipment, tunnel diode circuits, experiments, biasing tube equipment, relays etc. Charges nickel cadmium and other rechargeable batteries. Works on 110-130-volt 60-cycle ac. 24-inch test leads.—Seco Electronics, Inc., 1201 S. Clover Dr., Minneapolis 20, Minn.

TRANSIENT-VOLTAGE PROTECTOR SUBSTITUTION SELECTOR, Klipselector. Chooses optimum-size clamping device to protect semiconductor rectifiers, controlled rectifiers, transistors



against transients. Selector switches to choose non-polarized Klip-Sels having 1-20 series elements. Dialing device selects proper Klip-Sel in 26-volt steps, 26-520 volts. Connects directly to operating circuit.—International Rectifier Corp., 233 Kansas St., El Segundo, Calif.

TUBE TESTER, model 752A. For industrial and entertainment tubes, voltage regulators and all new tubes, compactrons, Novars, nuvions, 10-pin types. No elements paralleled. V-R tubes

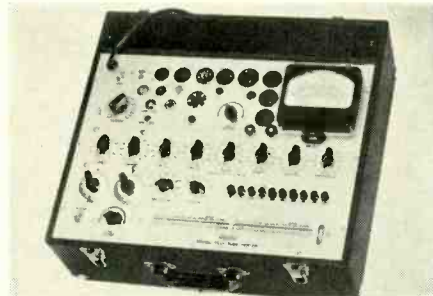

tested to manufacturer's specs including firing point, regulating voltage and current range. Panel button for second-section test in dual-section tubes.—Hickok Electrical Instrument Co., 10514 Dupont Ave., Cleveland 8, Ohio.

GRID-DIP METER, model TE-18. Used as grid-dip oscillator to find resonant frequencies of tuned circuits and as signal generator, absorp-



tion wave meter, field-strength meter and oscillating detector. Frequency range 360 kc-220 mc in 8 ranges. Coils letter-coded, marked in megacycles by frequency range. Planetary-drive tuning mechanism with 4:1 reduction gears. Grid-current meter has 500- μa movement. One-hand operation, on/off and oscillator-diode switch on front panel. Operates on 117 vac, 50-60 cycles.—Lafayette Radio Electronics Corp., 111 Jericho Turnpike, Syosset, N. Y.

PHOTOELECTRIC LINE FOLLOWER, type F-3. Converts almost any trace to electrical energy. Tracks curve slopes to 85° at chart speeds to 12 inches per minute, to 45° at 120 inches per minute. Follows square wave to 0.1 inch at 6 inches per minute. Built-in relays for external circuit control. Alarm circuit may be connected to

NO FREE premiums
NO PRIVATE labels
NO ineffective liquids
or carbon tet
ALL YOU GET IS
GENUINE

"NO NOISE"

QUALITY

- formulas developed by chemists
- 14 years of recognized leadership

BEWARE OF
CHEAP
IMITATIONS
INSIST ON
NO-NOISE



- VOLUME CONTROL and Contact Restorer
- TUNER-TONIC for all tuners including wafer type
- FORMULA EC-44 for all electrical contacts PLUS FREE with all No-Noise products, 5" plastic extender push-button assembly for pin-point applications. Does not cause shorts!

ELECTRONIC CHEMICAL CORP.

813 Communipaw Avenue Jersey City 4, N. J.

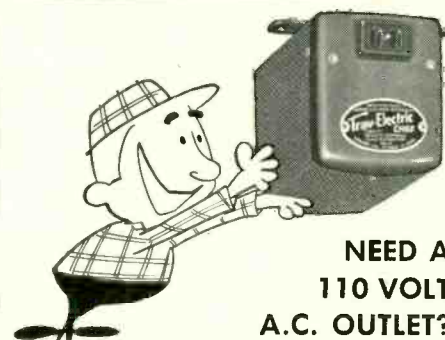

NEED A
110 VOLT
A.C. OUTLET?
IN CAR, BOAT or TRUCK,
YOU HAVE IT WITH A

terado POWER
INVERTER

Actually gives you 110 volt, 60 cycle A.C. from your 6 or 12 volt D.C. battery! Plug inverter into cigarette lighter, and operate lights, electric shavers, record players, electric tools, portable TV, radios, testing equipment, etc. Frequency will not change with change in load or input voltage.

Models from 15 to 300 watts, priced as low as **\$12⁹⁵** LIST

See Your Electronic Parts Jobber, or Write:

terado CORPORATION
1055 Raymond Ave.
St. Paul 8, Minn.

In Canada, ATLAS RADIO CORP. LTD. — Toronto, Ont.

IEEE

SEE

THE NEW
ELECTRONIC
WIZARDRY

at

I-TRIPLE-E's

International Convention
and Exhibition in New York

MARCH 25, 26, 27, 28

The COLISEUM at Columbus Circle
& The WALDORF ASTORIA HOTEL

admission: MEMBERS \$1.00; NON-MEMBERS \$3.00
MINIMUM AGE: 18

SHOW

(formerly the IRE Show)

RADIO-ELECTRONICS
154 West 14th St.
New York 11, N.Y.

GOOD PRICES FOR
GOOD PHOTOGRAPHS.

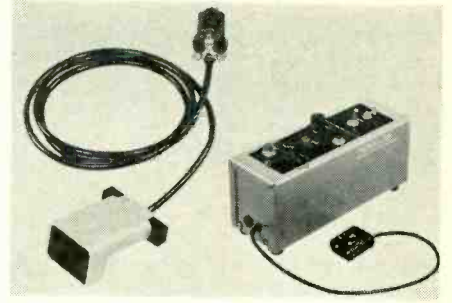

stop chart drive with excess tracking error or to control other functions.—F. L. Moseley Co., 409 N. Fair Oaks Ave., Pasadena, Calif.

AUTO DIODE TESTER. Forward or reverse tests of individual silicon rectifier diodes or complete rectifier banks on any alternators. Powered



by standard radio type carbon-zinc dry-cell battery, built-in battery-replacement indicator. Plastic-sleeved alligator clip on each cable.—Leece-Neville Co., 1374 E. 51 St., Cleveland 3, Ohio.

POWER METER, kit model HM-11. Shows antenna-transmitter match. Indicates forward or reflected power and vswr 1:1-3:1 on built-in meter. Band coverage 160 through 6 meters. Han-

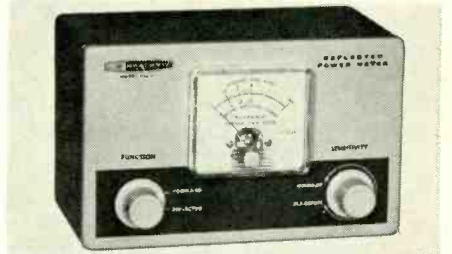

dles peak power over 1 kw, may be left in antenna-system feed line at all times. Components provided for matching 50- or 75-ohm antenna lines.—Heath Co., Benton Harbor, Mich.

SUBMINIATURE AUDIO TRANSFORMERS/INDUCTORS. In flat hermetically sealed steel case with mounting studs and straight pin terminals for welding or printed circuits. Connection data on case. Transformer operating level



100 mw, impedance range 50-20,000 ohms, response less than 2 db. Split inductors allow series or parallel connection, ranges 15 μ h at 64 ma. 1.5 ohms-2.4 h at 2 ma 160 ohms.—United Transformer Corp., 150 Varick St., New York 13, N. Y.

WIREWOUND RESISTORS, type SA. 18 sizes. 0.5 watt to 10.5 watts. Completely welded terminal-to-terminal construction. 0.5% drift in 1,000 hours operation at full wattage rating. Temperature coefficient .00002% C. Close tolerance

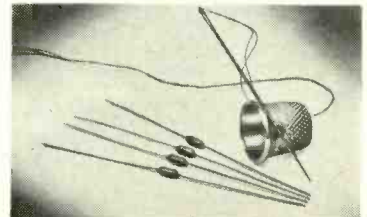

RADIO-ELECTRONICS

Give to the
MARCH OF DIMES

FIX ELECTRIC APPLIANCES

PAYS \$3 TO \$5 AN HOUR
Spare Time, Full Time • Learn at Home

FREE BOOK offered below shows how YOU can now have a good-paying business of your own, right in your home. No experience needed, just simple tools. Learn to repair Electric Appliances. Pays \$3-\$5 an hour!

400 MILLION Appliances are in American homes right now. 76 Million MORE bought each year. People need them fixed, good times or bad. YOU make good money doing it. In your basement, garage, even on your kitchen table.

Quick Way to Get Started For less than 20¢ a day our easy, pictured instruction—backed by 45 years of success in home training—prepares you for top earnings in this booming field. Earl Reid of Thompson, Ohio says: "Made \$510 in one month spare time. NRI course is priceless." At no extra charge you even get all parts for your own Appliance Tester, too. Finds trouble-spots, speeds and checks your work.

Get your FREE Book and FREE Sample Lesson! Mail coupon below, letter or postcard, now.

FREE BOOK • FREE LESSON

NATIONAL RADIO INSTITUTE, Appliance Division
Dept. FB3, Washington 16, D. C.

Send Free Book, Free Appliance Repair Course Lesson. Am interested in:

Spare Time Earnings My Own Business
 Better Job

Name

Address

City Zone State

Accredited Member—National Home Study Council

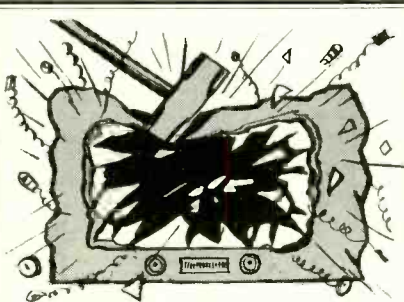

STOP

ARE YOU DOING THIS?

Every time a person turns on a TV or HI-FI set without a—

WUERTH SURGISTOR®

... he is ruining it. Protect the electronic equipment by preventing DESTRUCTIVE INRUSH CURRENT at "turn on." Easily installed. Saves callbacks.



Model 4100-2, 100-275 watts 117 V. \$1.95 List
Model 8050-4, 250-400 watts 117 V. \$2.95 List

See your dealer or distributor for this money-saving, equipment-saving Miracle Invention. Or, send order direct to us for prompt action.

WUERTH PRODUCTS CORP.

1931 Moffett St., Hollywood, Florida

to .05%, rated at 100°C ambient.—California Resistor Corp., 1631 Colorado Ave., Santa Monica, Calif.

DC/AC/DC TRANSDUCER for use as servo-feedback element on hydraulic control actuators, as position indicator for remote positioning systems, or as telemetering transducer. Variety of configurations and mountings. Typical unit op-

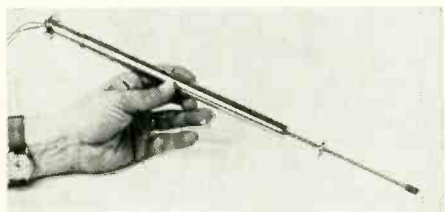

erates on 5-vdc excitation, provides 0 ± 15 -vdc output. Nominal power requirement 1/2 watt, output impedance approximately 15,000 ohms. Strokes 1/4 to ± 5 inches. Output linear 1/2% to 1%, depending on requirements. Resolution infinite. No wearing parts.—Humphrey, Inc., 2805 Canon St., San Diego 6, Calif.

SOLID-STATE BRIDGING AMPLIFIER, Bridgor-1. Input impedance 50 meg, 5 pf. output impedance 72 ohms. Bandwidth 1/2 cycle to 10 mc, 0.1% distortion at output 1 volt. Noise .01 μ v or

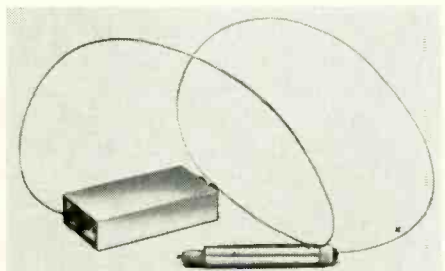

less within any 10-kc segments of the noise spectrum. Handles 5-volt peak signals, not affected by up to 500 volts ac or dc. Output voltage cannot exceed 10 volts peak. Amplifier in 3/4-in. diameter probe, connected by 1/8-in diameter, 5-foot-long cable to pocket-size battery box. Attaches to input of scope, meter or system for difficult ac measurements. Battery life 150 hrs.—DataService Corp., Harrison, N. Y.

TV/FM OUTDOOR ANTENNA, Omni-Ray model 3620-G. Electronically rotated; indoor switch for directional control without rotating antenna. Crossed-dipole system provides figure-8 reception pattern with deep nulls at each side. Front-to-side interference rejection ratio 10:1. Figure-8

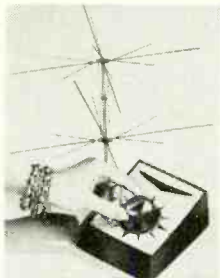

pattern rotatable in $22\frac{1}{2}^\circ$ steps, maintained on all channels, low and high bands, all directions. Model 3621-G, complete single bay kit. Model 3622-G, complete stacked antenna kit. Model 9535, 4-conductor Duo-Twin wire available in 100-foot lengths.—Channel Master Corp., Ellenville, N. Y.

INTERCOMMUNICATION AMPLIFIER, model CE-1300. Transistorized, portable; for construction, industrial and commercial use. Input impedance 100 ohms, output impedance 100 ohms. Sensitivity: 800-mw output at normal speaking

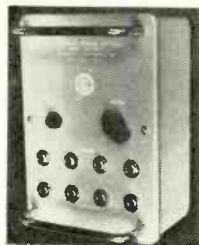

SCOTT STEREO TUNER KIT WINS RAVE REVIEWS



"The LT-110 met all the manufacturer's detailed specifications on sensitivity, distortion, output level, a.c. hum, and capture ratio. . . the audio response is excellent, being within ± 1 db, from approximately 20 to 16,000 cycles. . . Channel-to-channel crosstalk is particularly excellent both in terms of uniformity and the fact that it holds up."

Popular Electronics, Oct. 1962

"The LT-110 (is) so simple to build that we unhesitatingly recommend it for even the novice. . . We found that the usable sensitivity (IHFM) was 2.1 μ v. . . a fine stereo tuner and an unusually easy kit to build."

Audio, April 1962

"It seems to me that every time I turn around I am building another of H. H. Scott's kits. And each time I end up praising the unit to the skies.

American Record Guide, Sept. 1962

Now Sonic Monitor* Added

LT-110 \$159.95 (slightly higher West of Rockies). *Patent Pending



NEW KIT CATALOG . . . JUST OFF THE PRESS!

H. H. Scott, Inc., 111 Powdermill Road, Maynard, Mass.

Rush me your new kit catalog, your new "Guide to Stereo", Dept. 570-2

Name.....

Address.....

City.....State.....

Include name and address of interested friend and we'll send him these helpful Scott aids.

Export: Morhan Exporting Corp., 458 Broadway, N.Y.C.
Canada: Atlas Radio Corp., 50 Wingold Ave., Toronto



7 Ounce Headsets of Superior Quality

for: MUSIC ENJOYMENT - LANGUAGE LABS - AUDIO ANALGESIA - RADIO & TV STUDIOS - COMMUNICATIONS

Manufactured with dynamic (moving coil) drivers in impedances from 8 to 20,000 ohms with frequency characteristics from 30 to 15,000 cps. Constructed of un-breakable Royalite with removable ear cushions.

Of special interest to users such as schools are the porous ear cushions which allow air circulation eliminating perspiration in the ear canal and possible ear infection.

List prices range from \$15.95 to \$19.95. Mic booms optional. Write for detailed literature.

R-COLUMBIA PROD. CO., INC.

2008 St. Johns Ave. Highland Pk., Ill.



TRANSISTOR IGNITION

READY-TO-INSTALL CONVERSIONS

YOU can get TOP MILEAGE, HIGHEST PERFORMANCE, LONGER POINT & PLUG LIFE, BETTER WINTER STARTING, and MANY OTHER ADVANTAGES with one of our INEXPENSIVE TRANSFIRE systems. These include HERMETICALLY-SEALED AMPLIFIER, HIGH-RATIO COIL, BALLASTS, Leads & hardware.

MODEL T 6 or 12v. neg. grd. \$39.95

MODEL T2 TWO TRANSISTORS, 250:1 coil \$44.95

MODEL TP 6 or 12v. pos. grd. direct installation w/o. insulating points .. \$54.95

MODEL TS Special, 40kv system \$59.95

MODEL TS2 TWO TRANSISTORS, 400:1 coil \$49.95

TWO-TRANSISTOR KITS Everything needed to build conversion. Includes transistors, coil, ballasts, heat sink, decal, etc.

KT2 with TX250 coil for 30kv output . \$34.95

KT2 with T400 coil for 40kv output . \$39.95

KT1 Single Transistor with 400-1 coil \$29.95

6 or 12v. Negative-ground only. Point insulation kit adapts to positive ground, \$2.50 pp.

1 oz. Epoxy potting plastic in mixing bag \$1.95 pp.

HIGH-RATIO IGNITION COILS with free circuit diagram.

TX250 Heavy duty coil 250:1 ratio ... \$ 9.95

T400 HIGH EFFICIENCY 400:1 coil for HIGHER OUTPUT and/or LOWER TRANSISTOR VOLTAGE \$14.95

FULL LINE of PARTS at NET PRICES. Free lists. Dealer opportunities. Marine models available. When ordering, specify voltage and car. Add postage for 4 lbs. on kits and conv's; 3 lbs. on coils. \$5.00 deposit with COD's.

PALMER ELECTRONICS LABORATORIES Inc. CARLISLE 20, MASS. 617-AL 6-2626

BRITE 1963 SAVINGS

Guaranteed Quality Products

ORDER BY MAIL

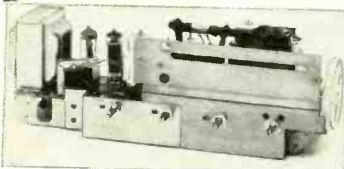

◀ **8 TUBE AM/FM COMBINATION RADIO TUNER AND AMPLIFIER CHASSIS**, complete with tubes. A fine quality unit that makes a wonderful accessory for your game room, den, etc. Automatic frequency control, tone control, phone input. Comes complete with simple installation instructions. Only **\$14.95**

5 TUBE AM CHASSIS 550 K.C. to 1600 K.C. COVERAGE — Complete with tubes and input for phono player. Limited quantity. **\$5.95**

THE WORLD'S SMALLEST TRANSISTOR PHONORADIO COMBINATION complete with vinyl carrying case, earphone and batteries. Plays 33 $\frac{1}{3}$ and 45 r.p.m. records. Carry it anywhere... dances, jam sessions, meetings, picnics, etc. Lightweight, portable. Excellent tone quality. **\$39.95**

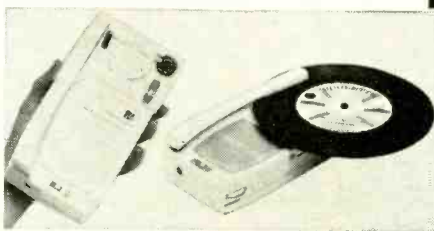

SPEAKER RIOT!

A complete assortment of first quality speakers. From 2 $\frac{1}{4}$ " miniatures to 12" Hi-Fi extended range speakers. All priced at sensational savings to you. No surplus merchandise.

- 2 $\frac{1}{4}$ " miniature speaker — 8 ohm voice coil imp. **98¢ ea.**
- 2 $\frac{1}{2}$ " miniature speaker — 8 ohm voice coil imp. **98¢ ea.**
- 2 $\frac{3}{4}$ " miniature speaker — 8 ohm voice coil imp. **98¢ ea.**
- 2 x 4 miniature speaker — 8 ohm voice coil imp. **79¢ ea.**
- 3" miniature speaker — 8 ohm voice coil imp. **\$1.10 ea.**
- 3 x 5 miniature speaker — 3.2 voice coil imp. **69¢ ea.**

(minimum of 3 assorted)

- 4" standard universal replacement type with transformer, 3.2 ohm voice coil imp. (Minimum quantity 3 for **\$2.99**).
- 4" standard universal replacement type 3.2 ohm voice coil imp. (Minimum 6 for **\$3.99**).
- 6 $\frac{1}{2}$ " Hi-Fi Extended Range Speaker — heavy Alnico 5 magnet 8 ohm voice coil. Wonderful tone quality. **\$1.39**
- 6" 3.16 magnet. **\$2.49**
- 6 x 9 auto replacement speaker 1 oz. magnet. **\$1.59**

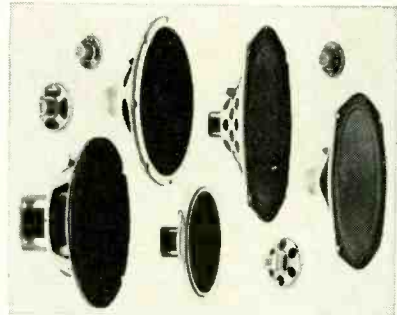

- 6 x 9 auto replacement speaker — heavy duty type. **\$2.15**
- 8" 2.15 magnet. **\$2.49**
- 8" 3.16 magnet. Shallow type. **\$2.95**
- 8" 6.8 magnet — Without cover. With duo cone. **\$3.75**
- 8" 6.8 magnet with cover and duo-cone. **\$3.95**
- 12" 6.8 magnet without cover. With duo-cone. **\$4.65**
- 12" 6.8 magnet with cover and duo-cone. **\$5.55**



HIGH FIDELITY PICTURE SPEAKERS. Beautifully designed pictures are actually speaker enclosures engineered for high fidelity sound projection. A colorful complement to any room. Hang on any wall, singly or in pairs, or use as extension speakers for greatest audio and visual effects. • Eliminates the need for bulky enclosures and cabinets. • Saves precious floorspace. • Attractive slim-line design.

- TAPE RECORDER MICROPHONE** — complete with cable and molded plug. **\$1.49**
- MINIATURE VOLUME CONTROL** with switch for Transistor Radio Replacement — 2.5K, 5K, 10K — Specify ohms. **59¢ ea.**
- BOOKSHELF ENCLOSURE** complete with Hi-Fi extended Range 6" Speaker — Beautiful Walnut Finish. **\$6.95 ea.**
- Same as above with 8" Speaker. **\$8.95 ea.**
- MINIATURE ELECTROLYTIC CONDENSER** — 100 mfd. — 10v. 10 for. **99¢**
- REPLACEMENT CARTRIDGE for B.S.R.**
- Monaural. **\$1.10 ea.**
- Stereo. **\$1.59 ea.**

RADAR DETECTIVE — Warns of radar speed traps as far away as $\frac{1}{2}$ mile. Fool-proof. Miniature size. Completely transistorized. No wires or antenna necessary. Sets on dash or attaches to sun visor. Complete with instructions. **\$29.95**

• Easily connected to stereo, hi-fi, phonographs, radios, tape recorders, organs, TV and amplifiers. "14 x 18" **\$18.95 ea.** — 2 for **\$36.50**. Includes 6" heavy duty Hi-Fi Ext. Range Speaker and mounting hardware. "20 x 24" **\$26.95 ea.** — 2 for **\$50.00**. Includes 8" heavy duty Hi-Fi Ext. Range Speaker and mounting hardware. Finished in Black Antique, White Antique or Natural. (Specify finish with order).

AUTO SPEAKER KIT

complete with grille and control kit. (Specify Faeder or 3 position switch kit. **\$12.65**

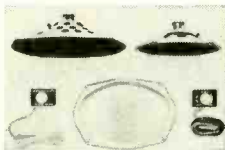

TO NE ARMS

Excellent Quality — complete with cartridge.

- Monaural turn-over **\$1.79**
- Fixed needle cartridge. **\$1.39**
- Stereo turn-over **\$1.99**

MINIMUM ORDER \$5.00

Send check or money order and include sufficient postage. Excess will be refunded. Sorry, no C.O.D.'s.

Complete satisfaction guaranteed or money refunded.

BRITE electronics

7 Garden Place, Baldwin, L. I., N. Y.

level. Output 1 watt max. Distortion 5%. 4 lb. Model CE-1300 AC/R, rack-mounted.—**Cambridge Electronics**, PO Box 1, Little Falls, N. J.

POCKET-SIZE WALKIE-TALKIE. Knight-Kit model C-100. All transistor self-contained CB voice unit for indoors and out. Standard 9-volt miniature battery operates for 75 hours. Trans-



ceiver's built-in 2-inch speaker serves as microphone. Crystal-controlled. Built-in telescoping 40-inch whip antenna, 9 oz.—**Allied Radio Corp.**, 100 N. Western Ave., Chicago 80, Ill.

MOBILE CB TRANSCEIVER, model M-523. 23-channel operation, transistorized dc power supply. Receiver section adjacent-channel rejection 60 db. Transistorized S-meter with illuminated dial,



rear-deck speaker kit. Ac power supply, plugged in with antenna, doubles as base station.—**Browning Labs, Inc.**, 100 Union Ave., Laconia, N. H.

CB TRANSCEIVER, model T & C 11. 6-channel crystal-controlled transmit and receive, manual tuning of all CB channels. Transmit crystal socket on front panel. Dual-conversion super-

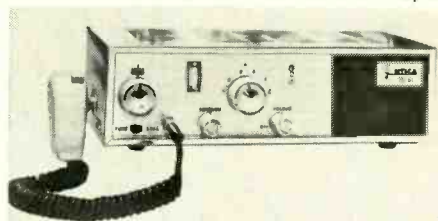

het, high-gain rf stage, equal response on all 22 channels. Universal power supply: 6 vdc, 12 vdc and 117 vac. Calibrated S-meter with output power modulation indicator, auxiliary speaker terminal. Supplied with 1 set of crystals.—**Utica Communications Corp.**, 2917 W. Irving Park Rd., Chicago 18, Ill.

TRIPLE-CONVERSION RECEIVER, model SX-117. For SSB, CW and AM operation. With low-frequency tuner accessory model HA-10, covers thirteen 500-kc segments 85 kc-30 mc. Crystals for 80-10-meter amateur bands. Standard broadcast, ship-to-shore and navigation bands



available with tuner. Crystal-controlled high-frequency oscillator on all ranges. Product detector for SSB and CW, plus envelope type for AM. T-notch heterodyne rejection, selectable sidebands, backlash-free tuning mechanism. Vfo can be crystal-locked on any frequency within tuning range.—**Hallcrafters Co.**, 5th & Kostner Ave., Chicago 24, Ill.

AM BROADCAST TUNER, model PK-633. Subminiature unit connected to any transistor audio amplifier. 3-transistor superhet circuit, wired on printed-circuit board. 3 i.f. transformers, built-in ferrite antenna. Circuit-board layout permits

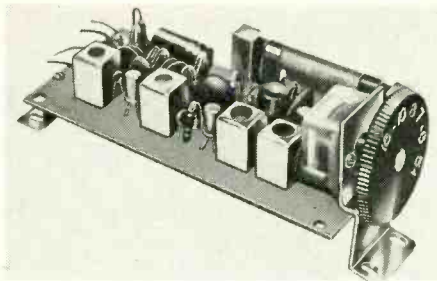

horizontal or vertical mounting. Mounting brackets. 4 x 1 3/4 x 2 in.—Lafayette Radio Electronics Corp., 111 Jericho Turnpike, Syosset, N. Y.

AM/FM STEREO MULTIPLEX RECEIVER, model KW-4. Power amplifier delivers 20 watts per channel at less than 1% harmonic distortion. Control center has inputs for low-level magnetic stereo phono cartridge and for high-level ceramic



or crystal stereo cartridge, provides RIAA phono equalization. Jack for stereo headphone listening, speaker cutoff switch for private listening. Tone controls, stereo balance control, rumble and noise filters, loudness compensation, blend control for stereo effect and alc.—Kenwood Electronics, 212 5th Ave., New York 10, N. Y.

TUNER KIT, model AJ-32. AM/FM/stereo FM. Stereo indicator, stereo phase control, 2 bar-type tuning indicators for AM and FM, slide-rule dial, flywheel tuning both bands, AM fidelity

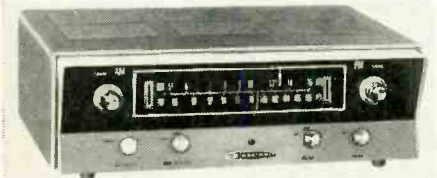

switch. Outputs have special filtering for stereo tape recording of off-the-air material without broadcast beat-note interference. Level controls, built-in AM and FM antennas. Matches AA-151 stereo amplifier. Assembled: model AJW-32.—Heath Co., Benton Harbor, Mich.

STEREO TAPE RECORDER, model 997. 6 low-impedance stereo outputs, illuminated studio type VU meters, motor-on indicator lights, mute monitor speaker switch. Inputs for stereo record changer and/or AM-FM and FM stereo tuner. Operates 4-track stereo record/play, 2-track stereo playback, 4-track monaural record/play, sound-with-sound. Multiple adjustment head allows in-

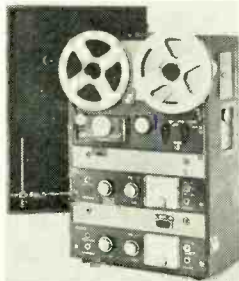

stant fingertip selection. Dual monitor speakers, professional lever type automatic shutoff, professional edit lever for instant stops. Dual head, preamp and power amp outputs, automatic interlocking controls. Operates vertically or horizontally. 3 3/4, 7 1/2, 15 ips. 24-slot wave-wound high-torque, hysteresis-synchronous fan-cooled motor; dynamically balanced rotor and flywheel.—Roberts Electronics, 5920 Bowcroft St., Los Angeles, Calif.

HI-FI, TAPE RECORDER ADAPTER, Part No. 352. Adapts stereo phonos or mikes for monaural use. Tip and ring of 3-conductor jack wired in parallel to tip of 2-conductor phone

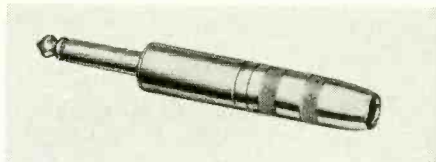

plug. Plugs into monaural tape recorder and stereo headphones or stereo mikes connected to adapter. No soldering. Adapter housed in nickel silver case.—Switchcraft, Inc., 5555 N. Elston Ave., Chicago 30, Ill.

PUSHBUTTON TAPE RECORDER, model RK-133L. 4-transistor push-pull amplifier, printed circuit. Pushbutton controls for fast rewind, off



and play. Safety interlock, volume control independent of on-off switch. Automatic erasure in record position. Operates on 9- and 1.5-volt batteries. Mike and earphone inputs. For 3-inch reel. Crystal lapel mike, magnetic earphone and batteries.—Lafayette Radio Electronics Corp., 111 Jericho Turnpike, Syosset, N. Y.

STYLUS PRESSURE GAUGE. Equal arm balance, assortment of exact weights. Permits ac-



curate adjustment of stylus pressure of any pickup arm. Only on direct order from manufacturer. \$1.00 postpaid.—Acoustic Research, Inc., 24 Thorndike St., Cambridge 41, Mass.

OMNIDIRECTIONAL MIKE, model 575 Versalyne. For PA, home recording, call systems. Hand-held, stand-mounted or lavalier. Dynamic



cartridge, slide-to-talk locking switch. Stand adapter, lavalier bracket and cord assembly. Frequency response 40-15,000 cycles. Output level —58 db, high impedance, 100,000 ohms recommended. Model 575SB, low impedance.—Shure Bros. Inc., 222 Hartrey Ave., Evanston, Ill.

MICROPHONE ISOLATION UNITS. Quick-disconnect devices convert desk or floor-stand-mounted mikes to hand-held types. Anodized aluminum; rubber inserts prevent "microphone swing"

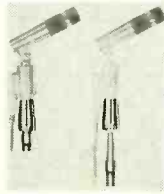

and shock. Model A45 for mikes with isolation assembly, model A47 for those with connectors.—Sales Dept., Shure Bros. Inc., 222 Hartrey Ave., Evanston, Ill.

LOUDSPEAKER, model RO-25T. Built-in line-matching transformers. Molded, bakelite, wa-

(Continued on page 114)



Olson



FREE

* Fill in coupon for a FREE One Year Subscription to **OLSON ELECTRONICS** Fantastic Bargain Packed Catalog—Unheard of LOW, LOW, DISCOUNT PRICES on Brand Name Speakers, Changers, Tubes, Tools, Hi-Fis, Stereo Amps, Tuners and thousands of other Electronic Bargains. Credit plan available.

NAME _____

ADDRESS _____

CITY _____ ZONE _____ STATE _____

If you have a friend interested in electronics send his name and address for a FREE subscription also.

OLSON ELECTRONICS, INC.

738 S. Forge St., Akron 8, Ohio







Multicores Sales Corp. Port Washington, N.Y.

For information, write Department MB 383

HE-20C DELUXE CITIZENS BAND TRANSCEIVER

Now Officially Approved For use in CANADA By Dept. of TRANSPORT Type Approval No. 169361029. Tops in CB world ■ 8 crystal controlled receive positions, 8 crystal controlled transmit positions ■ Tuneable over all 23 channels ■ Direct reading "S" meter indicates RF Power Output, Transmitter and Antenna Efficiency and Receiver "S" readings ■ Effective noise limiter ■ Built-in 12 or 6 volt power supply for mobile use. With crystals for channel 9.

No Money Down **109⁵⁰**



HE-20CWX



RECORDS
Sound-on-Sound

RK-140WX

4-TRACK STEREO TAPE DECK

Deluxe Professional Quality Built-in Transistorized Stereo Record/Play Preamps ■ Plays: 4-Track Stereo, 2-Track Stereo, and 4-Track Mono Tapes ■ Records: 4-Track Stereo or Mono and Sound-on-Sound ■ 2 Record Level Meters ■ Tape Index Counter ■ Automatic Stop at end of tape ■ 2 Speeds: 3¾ ips and 7½ ips ■ Frequency Response @ 7½ ips, 40-18,000 cps ■ Takes up to 7" reels.

99⁵⁰ less case
No Money Down

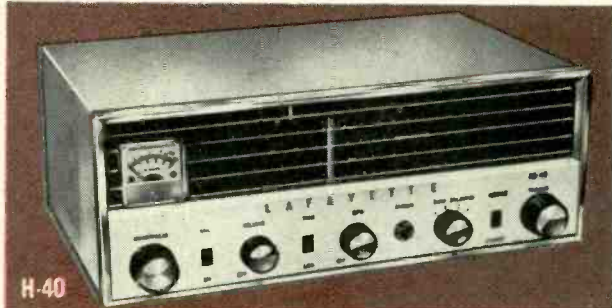

H-40

DELUXE 4-BAND SHORTWAVE BROADCAST RECEIVER

■ Tunes 550 kc to 30mc in four bands — Hear Europe, ships at sea, planes and amateurs ■ Sensitive superheterodyne circuit ■ Built-in "S" meter ■ Electrical bandspread ■ Receives voice or code

49⁹⁵
No Money Down

LAFAYETTE FOR
EYE-OPENING Values

LAFAYETTE STEREO MULTIPLEX TUNERS

33⁹⁵
EACH
2
for
62⁹⁰
No
Money
Down



HE-298L

LAFAYETTE 10-TRANSISTOR
CITIZENS BAND "WALKIE TALKIE"

50% more powerful—now with 10 transistors, plus diode, thermistor and extra RF stage ■ Transmits and receives up to 2 miles ■ Up to 50 hours battery life ■ Push-to-talk operation ■ Complete with leather case, earphone, antenna and batteries.



LT-78WX
FM-AM

FM-AM STEREO
MULTIPLEX TUNERS
89⁵⁰
No Money Down

FM
MULTIPLEX
TUNER

76⁵⁰
No Money Down



LT-81WX
FM on y

FEATURES OF BOTH LAFAYETTE TUNERS

Highest Quality Reception—Superb Styling! ■ Wide-band Design ■ Duplex 3-Gang tuning condenser provides tuned RF stage for greater sensitivity and selectivity ■ Built-in Multiplex with excellent separation ■ Sensitive tuning Meters ■ Variable AFC control ■ FM stereo Noise Filter ■ Smooth Flywheel Tuning.

FREE! FOR

'63

LAFAYETTE RADIO ELECTRONICS

1963 CATALOG NO. 630

388 GIANT-SIZE PAGES —

The Largest Catalog in Our 42-Year History

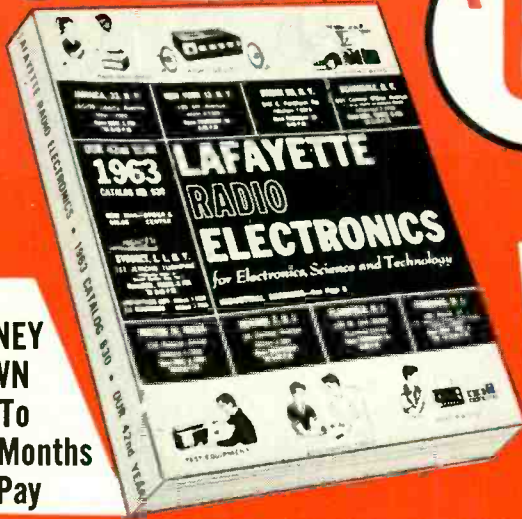

NO MONEY DOWN
Up To
24 Months
To Pay

from the
"WORLD'S
HI-FI
&
ELECTRONICS
SHOPPING
CENTER"

WHEN YOU BUY AT LAFAYETTE, YOU GET THESE EXCLUSIVE BENEFITS

- ★ OUTSTANDING LAFAYETTE KITS
- ★ LOWEST PRICES
- ★ 24-HOUR SERVICE

- SATISFACTION GUARANTEED OR MONEY REFUNDED. Use Lafayette's 30-Day FREE Home Trial.
- LARGEST STOCK SELECTION. If it's in Hi-Fi or Electronics, it's in the Lafayette Catalog.
- NO MONEY DOWN. Buy on time with Lafayette's Easy Pay Credit Plan, up to 24 months to pay.

TRUE, CUSTOM-MATCHED STEREO NEED NOT BE EXPENSIVE — and isn't at Lafayette!



LAFAYETTE
LA-224

GARRARD
AUTO SLIM
on Base



LAFAYETTE
SK-124 Speakers

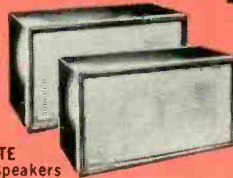

PICKERING
U38/AT Cartridge



ONLY
129⁵⁰
NO MONEY DOWN

YOU
SAVE
49.30

A COMPLETE 24-WATT STEREO PHONO SYSTEM

Only at Lafayette could you find an outstanding, custom-matched stereo system at such an amazing low price. Compare components, compare performance, compare price—you'll choose Lafayette.

LS-225WXM Specify: Pickering Cartridge; wood base finish; Speaker System finish. Shpg. wt., 64 lbs. Net 129.50

YOU GET THESE SYSTEM MATCHED COMPONENTS

Lafayette LA-224 24-Watt Stereo Amplifier	49.95
Garrard Autoslim 4-Speed Record Changer	39.50
Wood Base (Specify Walnut, Mhg. or Blonde)	3.95
Pickering U38/AT Diamond Needle Cartridge	46.50
2 Lafayette SK-124 2-Way Speaker Systems (Specify walnut or mahogany) @ 19.95 each	38.90

Regular Catalog Price ~~178.80~~

MAIL THIS COUPON TODAY for
YOUR FREE LAFAYETTE 630 CATALOG

Get One for a Friend Too

LAFAYETTE RADIO ELECTRONICS

Dept. JB3-2, P.O. Box 10, Syosset, L.I., N.Y.

- Rush my FREE 388-page giant-size Lafayette Catalog
- Send me #....., Shipping charges collect.

I am enclosing

Name

Address

City..... Zone..... State.....

Friend's Name

Address

City..... Zone..... State.....

FREE!



388
GIANT SIZE
PAGES

LAFAYETTE'S MAIL ORDER and SALES CENTER
SYOSSET, L. I., NEW YORK
111 Jericho Turnpike

NEW YORK, NEW YORK
100 6th Avenue

JAMAICA, NEW YORK
165-08 Liberty Avenue

BRONX, NEW YORK
542 E. Fordham Rd.

OTHER LOCATIONS
SCARSDALE, NEW YORK
691 Central (Park) Ave.

PLAINFIELD, NEW JERSEY
139 W. 2nd Street

NEWARK, NEW JERSEY
24 Central Avenue

PARAMUS, NEW JERSEY
182 Route 17

BOSTON, MASS.
110 Federal Street

NATICK, MASS.
1400 Worcester Street

free...
information
on the
world's
happiest
hobby!

ASSEMBLE IT AT HOME



ELECTRONIC ORGAN KITS

for home, school, church, clubs.

The Original "Build-it-Yourself" Organ
sounds like a glorious pipe organ

SAVE 70%
up to



Anyone Can Do It! Here's What You Get

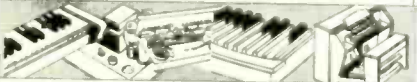

Manuals & Couplers, Tone Generator, Tone Changers, Pedal Keyboards, Consoles

Mail coupon below, and receive... absolutely FREE... complete information on Artisan's new 1963 Organ-Building Kit! Illustrated instructions lead you through every step of this happy hobby, as you assemble-at-home a magnificent custom Artisan electronic organ — the best in tone and styling! No technical skill required, and you save up to 70% of comparable ready-built organ costs by skipping dealer profits and factory labor! You can play as you build and pay as you build. From \$1750 to \$7500. Write today!

ARTISAN ORGANS 2476 R N.Lake Ave., Altadena, Calif.

NAME _____

ADDRESS _____

CITY _____ ZONE _____ STATE _____

Give to the
MARCH OF DIMES

**YOU
SAVE
MONEY!**

**RUSH US YOUR
LIST OF HI-FI
COMPONENTS
FOR A SPECIAL
QUOTATION**

**WRITE FOR FREE
AUDIO DISCOUNT
CATALOG A-15**

New low prices on
amplifiers, tuners, tape
recorders, speakers, etc.

KEY ELECTRONICS CO.
120 LIBERTY ST.
NEW YORK 6, N.Y.

(Continued from page 109)

terproof, shielded terminal blocks where transformer leads terminate. For use with 25-volt lines plus 70-volt and constant-impedance lines. Power, full range 25 w; power, adjusted range 50 w; fre-

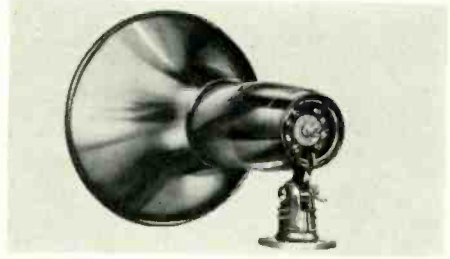

quency response 250-13,000 cycles; impedance taps (ohms) 45, 125, 250, 500, 1,000, 2,000, 5,000. Sound level 124 db. Designed for quick installation.—Racon Loudspeaker, Inc., 1261 Broadway, New York 1, N. Y.

HI-FI LOUDSPEAKER, Michigan MC8. Edgewise-wound voice coil, dual-cone Radax de-

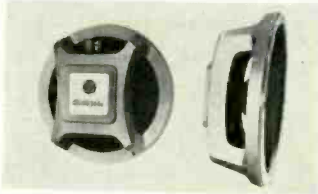

sign. Frequency response 50-13,000 cycles, power-handling capacity 12 watts program, 24 watts peak.—Electro-Voice, Inc., Buchanan, Mich.

AUDIO CONNECTOR WALL PLATE, model B3M (illus). 3-contact male receptacle with



captive design insert screw and ground terminal, mounted on single-gang wall plate. Model H3M, 2-gang wall plate. Choice of finishes.—Switchcraft, Inc., 5555 N. Elston Ave., Chicago 30, Ill.

TRANSISTOR PROTECTOR. Guards transistorized subassembly or single module. 3-terminal device for mounting in printed-circuit boards or for use with standard wire connections. Cylindrical shape, 13/16 in. long. Cap internally threaded,



straight knurled plastic, diam 0.687 inch. Panel thickness maximum 3/16-in. Dielectric phenolic threaded body houses plug-in Microfuse. Units for voltage protection 20-200 volts, overload currents .05-1.0 amp.—Littelfuse, Inc., Des Plaines, Ill.

SILICON RECTIFIER DIODES. Dissipate reverse power transients to 1 kw. Pigtail-mounted, flangeless, 0.570 inch maximum length. Rated at

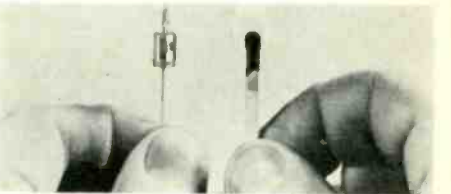

2 amps; built-in voltage-impulse-protection against reverse overvoltages. Reverse power dissipation 1 kw for 25-μsec transients.—General Instrument Corp., 65 Gouverneur St., Newark, N. J. END

All specifications are from
manufacturers' data

EDITORIAL (Continued from page 23)

transmitter is on the air. Thus patients will not interfere with each other.

Probably the best antenna for the patient will be an 8-inch, 1/2-inch-wide adhesive tape stuck to his forearm (See illustration). Processed inside the tape will be an 1/8-inch-wide insulated copper flexible conductor. Such an aerial will not get in the patient's way. The transmitter could send the signal to a nearby converter, which could put the signal on telephone lines, or amplify it for radio transmission to the doctor's office.

The system of automatically supervising dozens, or hundreds, of patients via wrist recorder becomes of vast importance in hospitals where nurses are always in short supply. Here, at a glance, a nurse can immediately see by her tape records which patient should have priority and immediate attention. Moreover, the chief nurse or supervisor can talk to any patient via a special loudspeaker in the patient's pillow

and inform him when a nurse will be free to see him.

The electronic-treated patient will soon be with us. More important, his health will be better and he will live longer.—H.G.

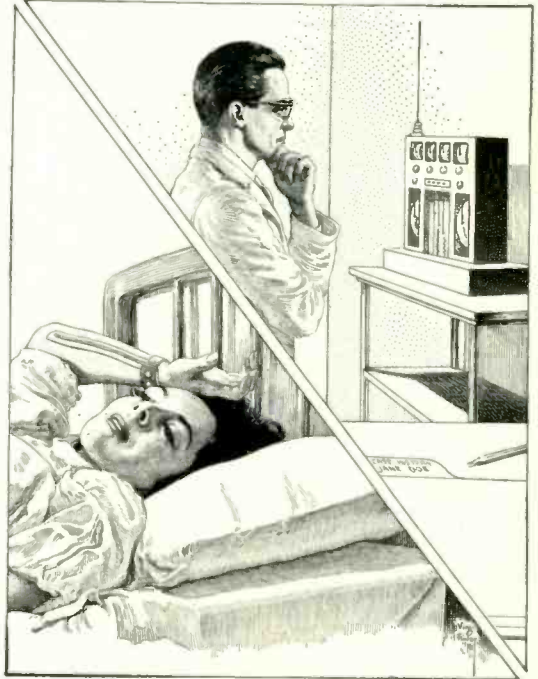

SCHOOL DIRECTORY

ANNOUNCING NEW NOW HIGH-PAY 2 New HOME-STUDY Professional CAREER COURSES Opportunities AS A TECHNICAL WRITER or ILLUSTRATOR — in Electronics!

SPONSORED BY NATIONAL DATA COMPANY — for applicants with 2 years radio or electronics experience. Minimum age 21. Requires high school education or equivalent. Spectacular career opportunities for trained men. Professional field—rewarding work— advancement — high earnings. No college required.

WRITE FOR FREE BULLETIN

Send outline of your education and electronics experience to Mr. Earl Hamilton, Director of Training, Technical Schools Division, Dept. C-12, NATIONAL DATA COMPANY, 1707 UNIVERSITY AVE., SAN DIEGO 3, CALIFORNIA

KEEP MOVING UP IN ELECTRONICS

ENGINEERING B.S. DEGREE IN 36 MOS. MATH SCIENCE

U.S. NEEDS 50,000 NEW ENGINEERS A YEAR! EARN ACCREDITED B.S. DEGREE in Science or Engineering in 36 months—year-round program optional. 27-month engineering diploma also available. Classes start March, June, September, January. QUALITY EDUCATION. Graduates employed throughout the U. S. and foreign countries. Government approved for veteran training. Students from 50 states, 40 countries. 20 buildings; dorms, gym. Campus. New library and laboratories. Employment help provided. SAVE TIME AND MONEY. Write for catalog and full information.

INDIANA INSTITUTE OF TECHNOLOGY
(Formerly Indiana Technical College)
1616 E. Washington Blvd., Fort Wayne 2, Indiana

ENGINEERING EDUCATION for the Space Age

NORTHROP INSTITUTE of Technology is a privately endowed, nonprofit college of engineering offering a complete Bachelor of Science Degree Program and TWO-YEAR accredited technical institute curricula. Students from 50 states, many foreign countries. Outstandingly successful graduates employed in aeronautics, electronics, and space technology. Write today for catalog—no obligation.

NORTHROP INSTITUTE OF TECHNOLOGY
1181 West Arbor Vitae Street, Inglewood 1, California



Engineering Technician A.S. Degree—2 Years Electronics Engineer B.S. Degree Evening Courses Available

ELECTRONIC TECHNICAL INSTITUTE
970 W. Manchester Ave., Inglewood, Calif.
4863 El Cajon Blvd., San Diego, Calif.

ELECTRONICS IS HIGHER INCOME!

Prepare NOW! EARN YOUR A. S. DEGREE IN 24 MOS.

DEMAND FOR ELECTRONIC ENGINEERING TECHNOLOGISTS EXCEEDS SUPPLY! Enroll with a nationally-recognized leader in electronics education. ECPD Accredited Technical Institute curricula in Electronic Engineering Technology and Commercial Broadcast Technology. Complete career preparation for booming fields of ELECTRONICS—COMMUNICATIONS—BROADCASTING—COMPUTER TECHNOLOGY—COMPUTER PROGRAMMING. College level resident and home-study courses. Coeducational. Up-to-date laboratories feature IBM, BENDIX and UNIVAC electronic computers and data processing equipment. SEND COUPON FOR COMPLETE CATALOG.

CENTRAL TECHNICAL INSTITUTE 1644 Wyandotte, Kansas City 8, Mo. RE023

Name _____ Age _____
Address _____
City _____ Zone _____ State _____

CHECK INTEREST: Resident Home Study

EARN Electronics DEGREE Engineering

You can earn an A.S.E.E. degree at home. College level HOME STUDY courses taught so you can understand them. Continue your education, earn more in the highly paid electronics industry. Missiles, computers, transistors, automation, complete electronics. Over 27,000 graduates now employed. Resident school available at our Chicago campus—Founded 1934. Send for free catalog.

American Institute of Engineering & Technology
1139 West Fullerton Parkway, Chicago 14, Ill.

GET INTO ELECTRONICS

V.T.I. training leads to success as technicians, field engineers, specialists in communications, guided missiles, computers, radar and automation. Basic & advanced courses in theory & laboratory. Electronic Engineering Technology, an ECPD accredited Technical Institute curriculum. Assoc. degree in 24 mos. B.S. also obtainable. G.I. approved. Graduates in all branches of electronics with major companies. Start Feb., Sept. Dorms, campus. High school graduate or equivalent. Catalog.

VALPARAISO TECHNICAL INSTITUTE
Department C, Valparaiso, Indiana



ENGINEERING DEGREE IN 27 MONTHS

Become an Electronics Engineer. College graduates enjoy higher income . . . advancement. Major corporations visit us regularly to interview and employ seniors. **BACHELOR OF SCIENCE DEGREE IN 27 MONTHS** in Electrical (Electronics or Power major), Aeronautical, Chemical, Mechanical, Civil Engineering. **IN 36 MONTHS** a B.S. Degree in Business Administration, One-Year Drafting-Design Certificate Program. Small classes. Well-equipped labs. Campus. Dorms, new library. *Moderate Costs.* Enter Mar., June, Sept., Jan. Founded 1884. Write J. G. McCarthy for Catalog and "Your Career in Engineering and Commerce" Book.

TRI-STATE COLLEGE
2423 College Avenue • Angola, Indiana

ENGINEERING DEGREES



Electronics, Mechanical. Also in Liberal Arts & Major Accounting earned by **HOME STUDY** Resident Classes Also Available if Desired Specify course preferred **PACIFIC INTERNATIONAL COLLEGE OF ARTS & SCIENCES** Primarily a correspondence school Chartered 1935

5719-M Santa Monica Blvd. Hollywood 38, Calif.

Sick and Tired of Working for "Peanuts"?

Then right now is the time to decide on a better life for you and your family. But griping and groaning won't do it. Determination will.

The rest is easy, once you've made up your mind to get the specialized training that can qualify you for higher pay, steady advancement and real recognition. Because I.C.S. can provide that training simply and inexpensively—in any of over 250 courses covering all of today's most rewarding job opportunities!

To show you how easy it is, we'd like you to have—FREE—the famous I.C.S. Success Kit, containing 3 profitable booklets that have helped thousands. Just clip and mail the coupon below.

International Correspondence Schools

Dean's Office, Box X7753A, Scranton 15, Pa. Please rush me FREE Success Kit containing 3 valuable booklets. My field of interest is:

(partial list of courses)

- Architecture
- Art
- Automotive
- Business
- Civil Engineering
- Drafting
- Electrical
- High School
- Mechanical
- Radio-TV Electronics
- Salesmanship
- Other _____

Name _____ Age _____
Street _____
City _____ Zone _____ State _____

FREE CAREER BOOKLET

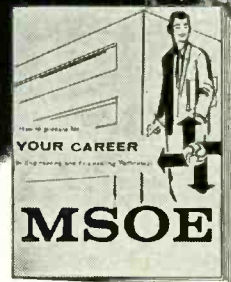

to guide you to a successful future in **ELECTRONICS RADIO-TV COMPUTERS ELECTRICAL ENGINEERING**

This interesting pictorial booklet tells you how you can prepare for a dynamic career as an Electrical Engineer or Engineering Technician in many exciting, growing fields:

MISSILES • RADAR • RESEARCH ELECTRICAL POWER • ROCKETRY AUTOMATION • AVIONICS SALES • DEVELOPMENT

Get all the facts about job opportunities, length of study, courses offered, degrees you can earn, scholarships, part-time work — as well as pictures of the Milwaukee School of Engineering's educational and recreational facilities. No obligation — it's yours free.

MILWAUKEE SCHOOL OF ENGINEERING

MAIL COUPON TODAY

MILWAUKEE SCHOOL OF ENGINEERING
Dept. RE-23, 1025 N. Milwaukee St.
Milwaukee, Wisconsin MS-113

Please send FREE "Your Career" booklet I'm interested in Electronics Radio-TV Computers Electrical Engineering Mechanical Engineering (PLEASE PRINT)

Name _____ Age _____

Address _____

City _____ Zone _____ State _____

I'm eligible for veterans education benefits.

Discharge date _____

PROFESSIONAL technicians use *Dave Rice's* OFFICIAL ORDER BOOKS for every TV-RADIO service call

This is the businesslike approach to service record keeping. TriPLICATE forms serve as order form, invoice and office record, with spaces for complete information on every job. Separate listings for receiving tubes, pix tube, parts, serial numbers, labor and tax charges, signatures, etc. 75c a book, \$6.50 for dust-proof box of 10. In stock at your distributor.

FREE

Write for your free folder describing Dave Rice's OFFICIAL ORDER BOOKS, including an actual size sample copy of the handy order form.

ELECTRONIC PUBLISHING CO., INC. 133 N. JEFFERSON ST. CHICAGO 6, ILLINOIS



BIRTH DEFECTS
ARTHRITIS
POLIO
AND
THE SALK INSTITUTE

25 YEARS MARCH OF DIMES FIGHTING DISEASE

SILICON TOP HATS OR DIODES 750 MA LOWEST PRICES GUARANTEED

LOW LEAKAGE NEWEST TYPE

PIV/RMS 50/35 .05 ea.	PIV/RMS 100/70 .10 ea.	PIV/RMS 200/140 .14 ea.	PIV/RMS 300/210 .20 ea.
PIV/RMS 400/280 .27 ea.	PIV/RMS 500/350 .32 ea.	PIV/RMS 600/420 .42 ea.	PIV/RMS 700/490 .55 ea.
PIV/RMS 800/560 .65 ea.	PIV/RMS 900/630 .75 ea.	PIV/RMS 1000/700 .85 ea.	PIV/RMS 1100/770 .95 ea.

100 Dif. Pre. Res. 1/2 W, 1 W, 2 W—1% Tolerance \$1.25
G.E. 1N91 Diode—10 for \$1.00, 100 for \$8.00

SILICON POWER DIODE STUDS

Amps	Volts	Sale	Amps	Volts	Sale
30	50	.15	35	200	\$2.20
100	30	.30	400	3.00	
200	20	.40	50	10	1.35
400	65	.65	50	25	1.55
600	75	.75	50	50	2.25
800	1.10	.70	50	100	3.25
30	70	.80	50	200	4.00
100	200	1.00	100	10	1.50
125	400	1.50	100	25	2.00
125	600	2.00	100	50	3.00
35	50	1.50	100	100	3.75
35	100	1.70	100	200	4.25

All material guaranteed. \$2.00 min. order. Orders F.O.B. NYC. Include check or money order. Shpg. charges plus. C.O.D. orders 25% down.

VAREN ELECTRONICS CO.
7, NY 87 Chambers St. WO 2-5727

new PATENTS

Relay Coil Tester

Patent No. 2,979,654

George L. Storm and Frank K. Vance, Winston-Salem, N.C. (Assigned to Western Electric Co., Inc., New York, N.Y.)

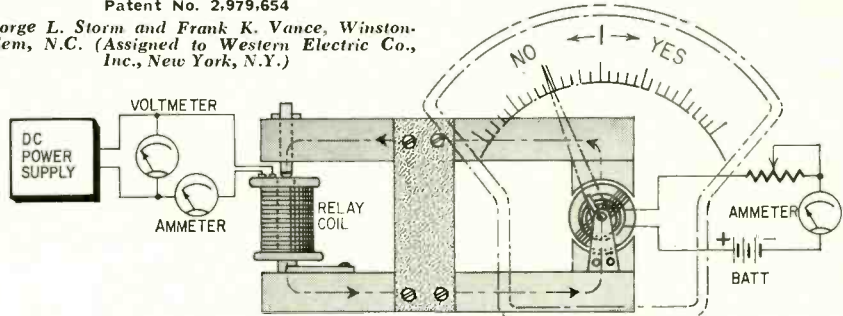

This device measures the magnetic strength of a relay coil. The indicator is a d'Arsonval movement used in reverse. Normally a permanent magnet surrounds a moving coil that is supplied with a variable current to be measured. Here, a predetermined current flows into the moving coil and the meter measures the strength of a relay-coil

magnet. Soft-iron pole pieces surround the d'Arsonval moving coil. The relay coil is placed in a jig and energized from a dc supply. The greater its magnetic force, the greater the deflection of the meter needle.

Transmitter Tester

PATENT No. 3,009,057

Marcus Glaser, Lawlerton, N.Y. (Assigned to Shell Electronics Manufacturing Corp., New York, N.Y.)

Maximum power from the nearby transmitter is picked up by the antenna when L-C is tuned to the proper frequency. A diode detects the signal. When S is thrown to the left, the meter indicates relative strength of the carrier. In other position, the rectified audio is amplified by a transistor and fed to the earpiece. This permits checking for distortion, hum, noise, level, etc.

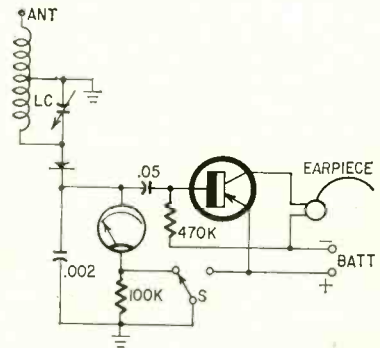

Two-Position Control

Patent No. 3,028,503

Ian W. Stevenson, c/o Kelvin Works, Glasgow, Scotland.

This instrument controls temperature by switching on a heater when it gets too cold, and switching on a cooler when it gets too hot. Within the intermediate range, both heater and cooler are off.

The moving-coil galvanometer indicates temperature and may be calibrated in degrees. It is mounted on a friction disc with two control arms which may be set independently to the desired temperature limits. Each control arm carries

a mirror, lamp and photocell. Normally, light from each lamp falls on its photocell. When this beam is interrupted, a relay (not shown) is energized.

When the temperature rises, the galvanometer pointer moves upscale until vane 2 blocks off light coming from lamp 2. This switches on the cooler. If the temperature falls, the pointer moves downscale until vane 1 blocks light from lamp 1. This turns on the heater.

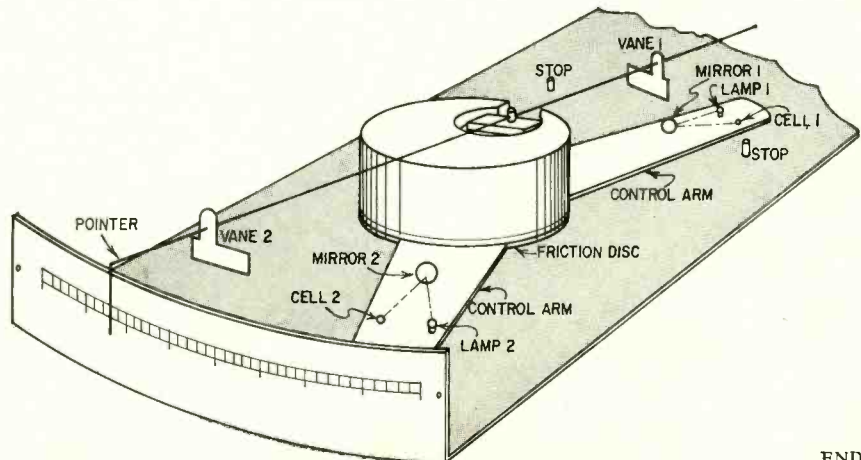

END

new BOOKS

CITIZENS BAND RADIO MANUAL (Vol. 2). Howard W. Sams & Co. Inc., 1720 E. 38 St., Indianapolis, Ind. 8½ x 11 in. 160 pp. \$2.95.

Diagrams, photos and servicing data on 30 models, as well as an index of both volumes.

BUILDING WITH ELECTRONICS, by Harry Zarchy. Thomas Y. Crowell Co., 432 Park Ave. So., New York, N. Y. 5½ x 8 in. 148 pp. Cloth, \$2.95.

A simple book, aimed at the younger reader and teaching him electricity and electronics through a large number of simple projects.

ABC'S OF RADIO NAVIGATION, by Allan Lytel. Howard W. Sams & Co. Inc., 1720 E. 38 St., Indianapolis 6, Ind. 5½ x 8½ in. 96 pp. \$1.95.

Discusses all types of electronic navigation, with special attention to equipment for small planes and boats.

ELECTRICAL PRINCIPLES OF ELECTRONICS, by Angelo C. Gillie. McGraw-Hill Book Co. Inc., 330 W. 42 St., New York 36, N. Y. 6 x 9 pp. 532 pp. Cloth, \$10.

An expansion of the fundamental laws and principles of electricity for technicians, electricians, home-owners and anyone else interested in electricity.

ALL ABOUT CROSSOVER NETWORKS, by Howard M. Tremaine. Howard W. Sams & Co. Inc., 1720

E. 38 St., Indianapolis 6, Ind. 80 pp. \$1.50.

Divided into four parts: general theory, design, construction, testing and use. Discusses 4- and 5-way networks as well as simpler ones.

INFORMATION PROCESSING LANGUAGE-V MANUAL, edited by Allen Newell. Prentice-Hall, Inc., Englewood Cliffs, N. J. 8½ x 11 in. 244 pp. \$6.

Details of a programming language (language-V or IPL-V) for nonarithmetic information processing, used on IBM, Remington-Rand, Bendix and Philco computers.

UNDERSTANDING TRANSFORMERS AND COILS, by Edward J. Bukstein. Howard W. Sams & Co. Inc., 1720 E. 38 St., Indianapolis 6, Ind. 5½ x 8½ in. 96 pp. \$1.95.

Covers low- and high-(radio) frequency units, their construction, application and testing.

INSTRUMENTATION FOR ENGINEERING MEASUREMENT, by R. H. Cerni and L. E. Foster. John Wiley & Sons Inc., 440 Park Ave. South, New York 16, N.Y. 6 x 9 in. 456 pp. Cloth, \$12.50.

Comprehensive discussion of techniques and equipment in various branches of engineering, including radio telemetry and nuclear reactors.

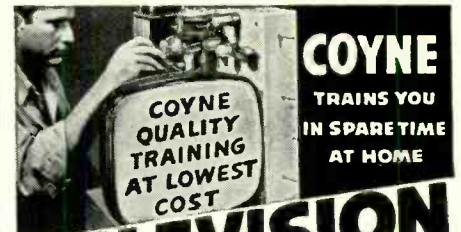

TELEVISION COLOR TV-RADIO-ELECTRONICS

Only from famous COYNE do you get this modern up-to-the minute TV Home Training. Easy to follow instructions—fully illustrated with 2150 photos and diagrams. Not an old Radio Course with Television tacked on. Includes UHF and COLOR TV. Personal guidance by Coyne Staff. *Practical Job Guides* to help you EARN MONEY QUICKLY IN A TV-RADIO SALES AND SERVICE BUSINESS—part time or full time. COSTS MUCH LESS—pay only for training—no costly "put together kits."

SEND TODAY FOR FREE BOOK

SEND COUPON or write to address below for Free Book and full details including EASY PAYMENT PLAN. NO COST OR OBLIGATION—NO SALESMAN WILL CALL.



B. W. COOKE Pres. **COYNE ELECTRICAL SCHOOL** FOUNDED 1899

CHARTERED AS AN EDUCATIONAL INSTITUTION NOT FOR PROFIT 1501 W. Congress Pkwy. Dept. 23-H5, Chicago 7, Ill.

COYNE Television Home Training Div.
New Coyne Building, Dept. 23-H5,
1501 W. Congress Pkwy., Chicago 7, Ill.

Send FREE BOOK and details of your Television Home Training offer.

Name _____
Address _____
City _____ State _____

I E E E

HEAR

DISTINGUISHED SPEAKERS & PANELISTS

at

I-TRIPLE-E's

International Convention
and Exhibition in New York

MARCH 25, 26, 27, 28

The COLISEUM at Columbus Circle
& The WALDORF ASTORIA HOTEL

admission: MEMBERS \$1.00; NON-MEMBERS \$3.00
MINIMUM AGE: 18

SHOW

(formerly the IRE Show)

Superior's New Model 820

TUBE TESTER

TESTS ALL MODERN TUBES
INCLUDING THE NEW

- ✓ NOVARS
- ✓ NUVISTORS
- ✓ 10 PINS
- ✓ 12 PIN COMPACTRONS

- Employs new improved emission circuit.
- Tests over 850 tube types.
- Tests 024 and other gas filled tubes.
- Employs new 4" meter with sealed air-damping chamber resulting in accurate vibrationless readings.
- Use of 26 sockets permits testing all popular tube types.
- Dual Scale meter permits testing of low current tubes.
- 7 and 9 pin straighteners mounted on panel.
- All sections of multi-element tubes tested simultaneously.
- Ultra-sensitive leakage test circuit will indicate leakage up to 5 megohms.

Model 820 comes complete with tube charts and instructions; housed in handsome, portable, Saddle-Stitched Texon case. Only **\$3850**

SHIPPED ON APPROVAL NO MONEY WITH ORDER — NO C. O. D.

Try it for 15 days before you buy. If completely satisfied then send \$5.00 and pay balance at rate of \$5.00 per month until total price of \$38.50 (plus postage) is paid — No Interest or Finance Charges Added! If not completely satisfied, return to us, no explanation necessary.

MOSS ELECTRONIC, INC.
DEPT. D-950 3849 Tenth Ave., New York 34, N.Y.
Please rush Model 820. If satisfactory, I will pay on terms specified. Otherwise I will return tester.

Name _____
Address _____
City _____ Zone _____ State _____

All prices net. F.O.B., N.Y.C.

R-E Classified ADS

Rates—55¢ per word (including name, address and initials). Minimum ad 10 words. Payment must accompany all ads except those placed by accredited advertising agencies. Three or more consecutive issues—50¢ per word. Misleading or objectionable ads not accepted. Copy for April issue must reach us before Feb. 10, 1963
RADIO-ELECTRONICS, 154 West 14 St., New York 11, N. Y.

SERVICES

METER REPAIRS—All makes and models. **BIGELOW ELECTRONICS**, Bluffton, Ohio.

TRANSISTORIZED products dealers catalog, \$1. **INTERMARKET**, CPO 1717, Tokyo, Japan.

ALL MAKES OF ELECTRICAL INSTRUMENTS AND TESTING equipment repaired. New and used instruments bought, sold, exchanged. **HAZELTON INSTRUMENT CO.**, 128 Liberty St., New York, N.Y.

SPEAKER RECONING. Satisfaction Guaranteed. **C & M RECONE CO.**, 255 Tioga St., Trenton, N.J.

TV Tuners—rebuilt or exchanged, \$9.95. Fast, Guaranteed. Complete crystal control alignment. **VALLEY TUNER SERVICE**, 18530 Parthenia, Northridge, Calif.

MULTIMETER REPAIRS. Average \$7.00 by. **BIGELOW ELECTRONICS**, Bluffton, Ohio. FREE Catalog.

JAPAN DIRECTORY. 145 manufacturing exporters. Japan and Hongkong trade Journal information. Asia opportunities. Send \$1.00. **NIPPON SHOGYO**. Box 739, Seattle 11, Wash.

PATENT. Drawings your invention made by our experts, reasonable cost. **PATENT SERVICE ASSOCIATES**, 6910 Madisonville Road, Cincinnati 27, Ohio.

WANTED

INVESTIGATE ACCIDENTS. Earn \$750 to \$1,000 monthly. Men urgently needed. Car furnished. Business expenses paid. No selling. No college education necessary. Pick own job location. Investigate full time, or earn \$6.44 hour spare time. Write for Free Book. No obligation. **UNIVERSAL**, CER-2, 6801 Hillcrest, Dallas 5, Tex.

CASH PAID! Sell your surplus electronic tubes. Want unused, clean radio and TV receiving, transmitting, special purpose, Magnetrons, Klystrons, broadcast types, etc. Want military & commercial lab/test and communications equipment such as G.R., H.P. AN/UPM prefix. Also want commercial receivers and transmitters. For a fair deal write **BARRY**, 512 Broadway, New York 12, N.Y. WAlker 5-7000.

PLATINUM electronic scrap bought. **NOBLE METALS CO.**, Box 543, Los Angeles 9, Calif.

G-R, H-P, L&N, etc., Tubes, manuals, military electronics. **ENGINEERING ASSOCIATES**, 434 Patterson Road, Dayton 19, Ohio.

WANTED FOR CASH. Old Radios manufactured before 1924. **WORCESTER**, RD1, Frankfort, N.Y.

EDUCATION/INSTRUCTION

EARN WHILE ASLEEP, Hypnotize with your recorder, phonograph or amazing new Electronic

Educator endless tape recorder. Catalog, details free. **SLEEP-LEARNING ASSOCIATION**, Box 24-RD, Olympia, Wash.

NEW CONCEPT OF LEARNING SELF-HYPNOSIS! Now on tape or record! Free Literature. **McKINLEY-SMITH CO.**, Dept. T5, Box 3038, San Bernardino, Calif.

FCC LICENSE in 6 weeks, First Class Radio Telephone. Results Guaranteed. **ELKINS RADIO SCHOOL**, 2603E Inwood, Dallas, Tex.

LEARN ELECTRONIC ORGAN SERVICING. New Home Study courses covering all makes electronic organ including transistors. Experimental kits—schematics—troubleshooting. Accredited NHSC-GI Approved. Write for free booklet. **NILES BRYANT SCHOOL**, 3631 Stockton Blvd., Dept. F. Sacramento 20, Calif.

LEARN HYPNOSIS. Free illustrated catalogue. Write: **HYPNOTIST**, 8721 Sunset, Los Angeles 69RE, Calif.

FOR SALE

General

BEFORE You Buy Receiving Tubes, Test Equipment, Hi-Fi Components, Kits, Parts, etc. . . . send for your Giant Free Zalytron Current Catalog, featuring all STANDARD BRAND TUBES all Brand New Premium Individually Boxed, One Year Guarantee—all at BIGGEST DISCOUNTS in America! We serve professional servicemen, hobbyists, experimenters, engineers, technicians, WHY PAY MORE? **ZALYTRON TUBE CORP.**, 461 Jericho Turnpike, Mineola, N. Y.

FREE CATALOG—name-brand tubes 65% discount, phono needles 80% or more discount, phono cartridges, picture tubes 75¢ inch, parts, parts kits, silicon and selenium rectifiers, transmitting tubes, 7" TV test tube \$6.99, imported batteries, tube testers etc. Want to swap or sell tube inventory? Send us your offering. **ARC-TURUS ELECTRONICS CORP.**—Dept. R.E., 502 22nd St. Union City, N. J.

100 NEW INSULATED CARBON RESISTORS \$1.00 postpaid. Free Catalog. **BIGELOW ELECTRONICS**, Bluffton, Ohio.

Electronics

SAVE DOLLARS on radio, TV tubes, parts at less than manufacturer's cost. 100% guaranteed! No rebrand, pulls. Request Bargain Bulletin. **UNITED RADIO**, 1000-R, Newark, N.J.

DIAGRAMS for TV, \$2.00; for radio, \$1.00. **HIETT DIAGRAMS**, Box 816, Laredo, Tex.

TRANSISTOR IGNITION COIL—Instructions. SPECIAL—\$8.50. **ANDERSON ENGINEERING**, 16 Williams, Wrentham, Mass.

PROFESSIONAL ELECTRONICS PROJECTS—Organs, Timers, Computers, etc.—\$1 each. List free. **PARKS**, Box 1665, Lake City, Seattle 55, Wash.

SUPERSENSITIVE DIRECTIONAL MICROPHONE picks up faint sounds at 300 feet. Detects sound through ordinary walls. Easily built for \$7.00. No electronic experience necessary. Illustrated plans, \$2.00. **DEE CO.**, Box 7263-A, Houston 8, Tex.

TRANSFIRE IGNITION. Transistor electronic. Save gas, tune-ups. Points, plugs last 50,000-100,000 miles. Improved cold-starting high-speed performance. Parts, complete conversions, kits from \$34.95. **PALMER ELECTRONICS**, RE-1, Carlisle, Mass.

CONVERT ANY TELEVISION TO SENSITIVE, Big-screen oscilloscope. Only minor changes necessary. Plans \$1.95. **RELCO**, Box 10563, Houston 18, Tex.

PRECISION RESISTORS, carbon-deposit. Guaranteed 1% accuracy. Millions in stock. 1/2 watt, 8¢. 1-watt, 12¢. 2-watt, 15¢. Leading manufacturers. **ROCK DISTRIBUTING CO.**, 902 Corwin Rd., Rochester 10, N.Y.

DIAGRAMS FOR REPAIRING RADIOS, \$1; television \$2. Give make and model. **DIAGRAM SERVICE**, Box 672 RE, Hartford 1, Conn.

CONFIDENTIAL BARGAIN Electronic Parts catalog, lowest prices in USA. Guaranteed. Send 20¢ coin only. **KNAPP**, 3174 8th Ave. SW, Largo, Fla.

WEBSTER ELECTRIC INTERCOMS! Amateur Equipment! Marine Electronics! All Select Bargains! 10¢ Any list! **SUPPLIERS**, 187 Miraloma, Miraloma, Calif.

BEGINNER'S CRYSTAL-TRANSISTOR giant catalog. **LABORATORIES**, 1131-B Valota, Redwood City, Calif.

Audio—Hi-fi

WRITE for our low quotation on components, recorders. FREE catalog. **HI-FIDELITY SUPPLY**, 2817-XC, Third Ave., New York City 55.

TAPE recorders, Hi-Fi components, Sleep-learning equipment, Tapes, Unusual values. Free catalog. **DRESSNER**, 1523 Jericho Turnpike, New Hyde Park 5, N.Y.

RENT STEREO TAPES—over 2,500 different—all major labels—free catalog. **STEREO-PARTI**, 811-RE, Centinela Ave., Inglewood 3, Calif.

SALE ITEMS—tapes—recorders—component quotes. **BAYLA**, Box 131-RE, Wantagh, N. Y.

ATTENTION: A THRILLING FIND: We have just uncovered a collection of original antique Edison Cylinder Phonographs, released from 50 years of storage. Each in perfect working order and shape. Each complete with outside concert horn with stand and 12 original cylinders. Each \$70.00, extra cylinders \$1.00 each. **TRACY STORAGE CO.**, 114 State, Brewer, Me.

4/TR STEREO TAPES—bought, sold, rented, traded! Bargain closeouts! Catalog/COLUMBIA 9651 Foxbury, Rivera, Calif.

STEREO TAPES FOR RENT. Write **NATIONAL TAPES**, 71 Dey St., New York 7, N.Y.

VIBRATION MICROPHONE, many uses. Instructions, Sample, \$1.00. **IGWTE**, Williamsburg, N. M.

MISCELLANEOUS

\$100 WEEKLY POSSIBLE. Compile mailing lists and address envelopes for advertisers. Home-spare time. Particulars free. **NATIONAL SERVICE**, 81 Knickerbocker Station, New York, N. Y.

MAKE \$25-\$50 WEEK CLIPPING newspaper items for publishers. Some clippings worth \$5.00 each. Particulars free. **NATIONAL**, 81 Knickerbocker Station, New York N. Y.

EXOTIC EARRINGS! Details Free. Pair, \$1.00. **OHGA**, RA-415, Sigakenkusatu, Japan.

IDEAS? Publish in, Subscribe to the **JOURNAL OF SCIENTIFIC CONTROVERSY**. Four issues: \$4. Box 855, Boulder, Colo.

BUSINESS AIDS

BUSINESS CARDS, LABELS, RUBBER STAMPS. Send for free descriptive literature, **HEIGHTS INDUSTRIES**, 6121 C Street, Capitol Heights 27, Md.

250 BOND 8 1/2 x 11 letterheads, 250 Envelopes Printed \$5.50. **ACADEMY PRESS**, Enterprise, Kan.

1,000 BUSINESS CARDS \$3.95. Many other bargains. List Free. **ALCO**, Box 244-R, Urbana, Ill.

RUBBER STAMPS MADE TO ORDER. Write for price lists. **DELUXE STAMP WORKS**, Box 46, Auburn, Nebr.

QUALITY RUBBER STAMPS, Modern prices. FREE Catalog. **MELCO**, Box 53331-RE, New Orleans 50, La.

LETTERHEADS, BILLHEADS, STATEMENTS, ENVELOPES—Complete set \$9.95 postpaid—two color \$12.95 (Samples). **OKAYPRINT**, Martins Ferry 3, Ohio.

1,000 Business Cards, "Raised Letters" \$3.75 postpaid. Samples. **ROUTH**, RE-2, 3910 Kipling, Greensboro, N. C.

IF YOU CHANGE YOUR ADDRESS... PLEASE NOTIFY US

For most efficient service, send us the actual address label pasted on the lower right corner of the front cover. If not possible, send your name and new address with all numbers appearing on label. Include postal zone of the new address, if any.

IMPORTANT: Don't delay. Tell us your new address as soon as you know it so that you receive Radio-Electronics without interruption.

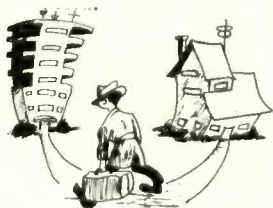

Send data to:

RADIO-ELECTRONICS
SUBSCRIBER SERVICE
154 West 14th Street, New York 11, N. Y.

FEBRUARY, 1963

SATISFYING CUSTOMERS FOR PROFIT, An Electronic Industries Association Project. **Howard W. Sams & Co. Inc.**, 1720 E. 38th St., Indianapolis 6, Ind. 6 x 9 in. 96 pp. \$1.25.

Discusses the most important of all service techniques—satisfaction engineering. In easy-to-read "Red and Bob" dialogue style, with dead-serious summing up at the end of each narrative.

ELECTRON DEVICES AND CIRCUITS, by John M. Carroll. McGraw-Hill Book Co. Inc., 330 W. 42 St., New York 36, N. Y. 6 x 9 in. 344 pp. Cloth, \$8.75.

A fundamental guide to the structure and operation of electronic devices and their applications in many types of electronic circuits.

BASIC MATH COURSE FOR ELECTRONICS, by Henry Jacobowitz. Gernsback Library Inc., 154 W. 14th St., New York 11, N. Y. 5 1/2 x 8 1/2 in. 160 pp. Paper, \$4.50.

Starting with Ohm's law, this home-study course shows the beginner (with examples and problems) how to use network algebra, trig, vectors and logarithms. It includes log and db tables as well as useful formulas.

BASICS OF GYROSCOPES (Vols. 1 and 2), by Carl Machover. John F. Rider Publisher Inc., 116 W. 14 St., New York 11, N. Y. 6 x 9 in. 101 and 114 pp., respectively. \$3.30 per volume in soft cover, \$7.75 per set in cloth binding.

Vol. 1 introduces the gyroscope and covers basic theory. Vol. 2 covers specialized types including rate and integrating types, stable platforms and gyro construction and applications.

UNDERSTANDING TRANSISTORS AND HOW TO USE THEM. Allied Radio Corp., 100 N. Western Ave., Chicago 80, Ill. 5 1/2 x 8 1/2 in., 96 pp. Paper, \$3.90.

A little theory, followed by such do-it-yourself projects as an amplifier, simple radio, timer and flasher.

1962 REPLACEMENT GUIDE FOR TV AND AUTO RADIO CONTROLS. Howard W. Sams & Co. Inc., 1720 E. 38 St., Indianapolis 6, Ind. 8 1/2 x 11 in. 128 pp. \$1.

A cross-referenced replacement guide listing Centralab, Clarostat, CTS-IRC and Mallory part numbers for resistive type controls in 30,640 TV models and 1,286 auto radios.

RCA TRANSISTOR MANUAL, SC-10. RCA Semiconductor and Materials Div., Somerville, N. J. 5 1/2 x 8 1/2 in. 304 pp. Paper, \$1.50.

Written in the RCA tube manual style, it will satisfy the experimenter, student and technician. Includes diode data and practical schematics.

THE CONTROLLED RECTIFIER, Vol. 1. International Rectifier Corp., El Segundo, Calif. 6 x 9 in. 132 pp. Paper, \$2.50.

Theory, testing procedures and characteristics explained with the help of many graphs.

MEDICAL ELECTRONICS, edited by C. N. Smyth. Iliffe & Sons Ltd., London, England. U.S. edition by Charles C. Thomas Publisher, Bannerston House, 301-327 E. Lawrence Ave., Springfield, Ill. 6 1/2 x 10 in. 614 pp. Cloth, \$29.50.

A complete report on the proceedings of the Second International Conference on Medical Electronics, held in Paris in 1959. All types of electronic medical instruments were discussed. END

Television RADIO-ELECTRONICS Electricity ELECTRONICS IN NEW SHOP-LABS OF COYNE

TRAIN QUICKLY! OLDEST, BEST EQUIPPED SCHOOL of ITS KIND in U.S.

Get practical training in New Shop-Labs of Coyne. Prepare for a better job and a successful future in a top opportunity field. Advanced education or previous experience not needed. Employment service to graduates.

Enroll NOW—Pay Later
Finance Plan and Easy Payment Plan. Also Part Time Employment help for students.

FREE BOOK Clip coupon or write for Free Illustrated Book, "Your Opportunities in Electronics"—Describes all training offered. No obligation and No Salesman Will Call. Act NOW

B. W. Cooke, President
COYNE CHARTERED NOT FOR PROFIT
ELECTRICAL SCHOOL Established 1899
1501 W. Congress Pkwy. Chicago, Dept. 23-N

COYNE Electrical School
1501 W. Congress Pkwy., Chicago 7, Ill.
Dept. 23-N

Send FREE book "Your Opportunities in Electronics" and details of all training you offer.

NAME.....
ADDRESS.....
CITY.....STATE.....

SUPER "WISSH" WITH SILICONE

ELECTRONIC CLEANER and LUBRICANT

NEW

POCKET SIZE
AEROSOL SPRAY

Model No. 53



Free
SPRAY TUBE

78¢
DOL. NET

MANUFACTURED BY
WORKMAN Electronic
SARASOTA, FLORIDA PRODUCTS, INC.

ADVERTISING INDEX

Allied Radio	71-72
Anglo American Acoustics Ltd.	63
Arco Electronic Supply Co. (Arcolytic Div.)	16
Artisan Organs	114
Audio Unlimited	73
B & K Manufacturing Co.	17, 63
Barry Electronics Corp.	95
Brite Electronics	108
British Industries Corp. (Multicore Sales Div.)	109
Brooks Radio & TV Corp.	96-97
Burstein-Applebee Co.	97
Capitol Radio Engineering Institute	52-55
Carson	73
Castle TV Tuner Service	8
Centralab. Div. of Globe-Union	75, 77
CLASSIFIED ADS	118-119
Cleveland Institute of Electronics	80-83
Colordaptor	97
Conar Instruments (Div. of National Radio Institute)	95
Coyne Electrical School	117, 119
Coyne School Publications	85
Datak Corp.	56
Denson Electronics Corp.	62, 120
DeVry Technical Institute	7
Dynascan Corp. (B & K Division)	17
Electro-Voice Inc.	13
Electronic Chemical Corp.	105
EICO Electronic Instrument Co.	22
Electronic Measurement Corp. (EMC)	98
Electronic Publishing Co. Inc.	116
Elpa Marketing (Thorens)	21
Euphonics Corp.	99
Fair Radio Sales	89
GM Photoelectronics	89
Gernsback Library Inc.	18
Graham School of Electronics	11
Gregory Electronics Corp.	88
Heald's Engineering College	120
Heath Company	64-65
I-Triple-E (I. E. E. E.)	84, 106, 117, 120
International Crystal Mfg. Co. Inc.	57
International Resistance Co.	9
JFD Electronics Corp.	60-61
Jerrold Electronics Co. (Subsidiary of Jerrold Corp.)	3
Key Electronics Co.	114
Lafayette Radio	110-113
(P. R.) Mallory Co. Inc.	87
Moss Electronic Inc.	117
Multicore Sales Corp. Div. of British Industries	109
National Radio Institute	19-20, 106
National Technical Schools	5
Olson Radio Corp.	109
Palmer Electronics	107
Polypaks	84
Progressive Edu-Kits Inc.	104
R-Columbia Products Co., Inc.	79, 107
RCA Electron Tube Division	Back Cover
RCA Institutes	100-103
Rad-Tel Tube Co.	69
Radio-Electronic Master	90-93
Relco	89
Rohn Manufacturing Co.	73
(Howard W.) Sams & Co., Inc.	15, 94
Schober Organ Co.	58
(H. H.) Scott Inc.	107
Secore	67
Sonar Radio Corp.	62
Sprague	14
Standard-Kollsman Industries Inc.	Third Cover
Sarkes Tarzian Inc. (Tuner Div.)	79
Supreme Publications	88
Terado Corp.	105
Triplett Electrical Instrument Co.	Second Cover
The Turner Microphone Co.	89
Utah Electronics Corp.	10
Utica Communications Corp.	74
Warren Electronics Co.	116
Weller Electric Co.	12
Winegard Company	59
Workman Electronic Products Inc.	119
Wuerth Products Corp.	106

SCHOOL DIRECTORY page 115

American Institute of Engineering & Technology
Central Technical Institute
Electronic Technical Institute
Indiana Institute of Technology
International Correspondence Schools
Milwaukee School of Engineering
National Data Company
Northrop Institute of Technology
Pacific International College of Arts & Sciences
Tri-State College
Valparaiso Technical Institute

Printed in USA.

SERVICE TECHNICIANS ASSOCIATIONS
 CLUB MEMBERS • INDUSTRIAL EMPLOYEES
 STUDENT GROUPS
 YOU QUALIFY FOR
SUBSCRIPTION RATES TO
Radio-Electronics
 Write Mr. G. Alguo • Radio-Electronics • 154 West 14th Street, New York 11, N. Y.

IEEE

SPEAK

TO OUTSTANDING
ELECTRONICS ENGINEERS,
SCIENTISTS, PHYSICISTS

at

I-TRIPLE-E's

International Convention
and Exhibition in New York

MARCH 25, 26, 27, 28

The COLISEUM at Columbus Circle
& The WALDORF ASTORIA HOTEL

admission: MEMBERS \$1.00; NON-MEMBERS \$3.00
MINIMUM AGE: 18

SHOW

(formerly the IRE Show)

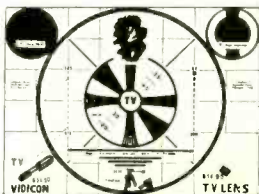

TV-CAMERA
BUILT AT LOW COST
DETAILS 50¢
"Write for Catalog
#1273."
DENSON
ELECTRONICS
CORP.
Box 85,
Rockville, Conn.

SAVE MONEY

HI-FI COMPONENTS

TAPE RECORDERS
SLEEP LEARN KITS

MERITAPE Low cost, high quality recording
tape, in boxes or cans.

DRESSNER FREE 1963 CATALOG
1523 JERICHO TPKE.
NEW HYDE PARK 17, N.Y.

ELECTRONICS

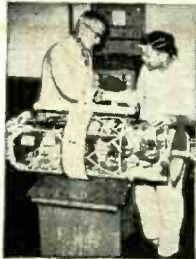

Engineering-Technicians

Heald's Micro-wave and Radar Laboratory Equipment.

Bachelor of Science Degree, 30 Months
Save Two Years' Time

The Nation's increased demand for Engineers, Electronic Technicians, Radio TV Technicians is at an all time high. Heald

Graduates are in demand for Preferred High Paying Salaries. Train Now for a lucrative, satisfying lifetime career.

- Radio-Television Plus Color Technician (12 Months)
- Electronics Engineering Technology (15 Months)
- Electronics Engineering (B.S. Degree)
 - Electrical Engineering (B.S. Degree)
 - Mechanical Engineering (B.S. Degree)
 - Civil Engineering (B.S. Degree)
 - Architecture (B.S. Degree)

Approved for Veterans
DAY AND EVENING CLASSES

Write for Catalog and Registration Application.
New Term Starting Soon.

Your Name _____

Address _____

City _____

State _____

HEALD'S ENGINEERING COLLEGE

Established 1863

Van Ness at Post, RE
San Francisco, Calif.

Standard Made It...

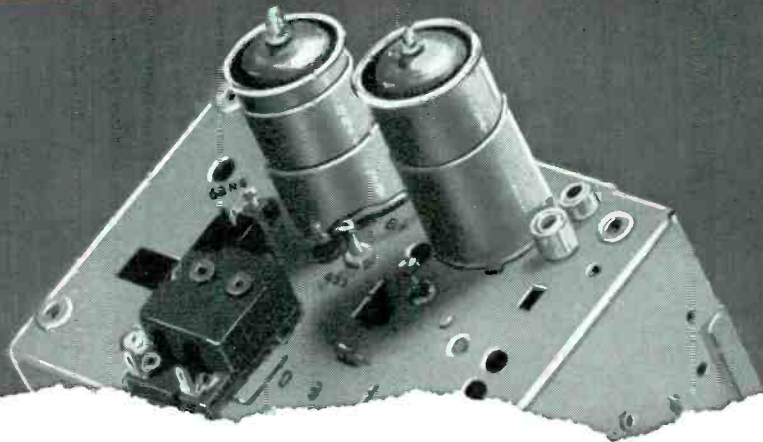

STANDARD CAN FIX IT BEST

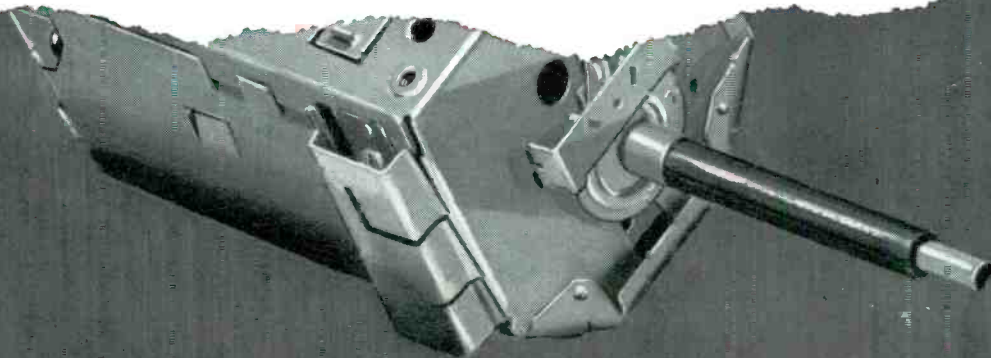

\$11⁵⁰ Plus Parts . . . \$13.50 Maximum Total Cost

FREE *Specially designed shipping cartons to prevent damage in transit*

**6 Months
GUARANTEE**

Only BRAND NEW PARTS Used - 48 Hour
Service on All STANDARD Tuners - Latest
Testing Techniques Assure Proper Alignment -
\$3.00 Defective Tuner Trade-in Allowance
Against a New STANDARD Replacement Tuner
Carrying a 12 MONTH GUARANTEE

IN TV IT'S *Standard*

STANDARD has maintained uniform mounting centers for the last 13 years. Over 50% of the TV sets in existence today have STANDARD tuners—in the case of most other tuners one of the 8 STANDARD replacement models can be easily adapted or will fit directly in place of these units. All STANDARD replacement tuners carry a 12 Month Guarantee.

**SEE YOUR AUTHORIZED
STANDARD DISTRIBUTOR**

**MORE PROFIT FOR THE SERVICE DEALER • GREATER CUSTOMER SATISFACTION
GUARANTEED BY THE WORLD'S LARGEST TV TUNER MANUFACTURER**

***standard kollman* INDUSTRIES INC.**

FORMERLY STANDARD COIL PRODUCTS CO., INC., MELROSE PARK, ILLINOIS



WHERE SILVERAMA® GETS A NEW FACE

Complete rescreening means sharp, clear TV pictures from each RCA Silverama

These RCA Silverama picture tube bulbs are getting a new phosphor screen—the “face” they will one day show to your customers.

As they inch their way along this vibration-free settling belt in our Marion, Indiana picture-tube plant, a suspension of phosphor particles settles slowly from a chemical solution in each bulb, depositing a smooth new screen over the faceplate.

This is one of the final steps in the rescreening process. Prior to re-use each glass envelope has been rigorously inspected. Its exterior has been buffed and polished to mirror-smoothness. Then in

a series of acid baths and water rinses, the interior has been scoured of its former coatings and delicately etched to restore it to the peak of its optical capability. Only when chemically clean inside and out is it ready for its new screen.

These exacting techniques—and the precision engineering behind them—provide every RCA Silverama picture tube with the best picture-making capabilities modern technology can produce. They are your assurance that you install the finest when you install Silverama.

Phosphor blending tanks. Here the proper blend of screen phosphor particles is mixed with a solution of ultra-pure demineralized water and settling chemicals. Mechanical blenders, providing a uniform suspension, help assure the perfectly even screen that characterizes Silverama.

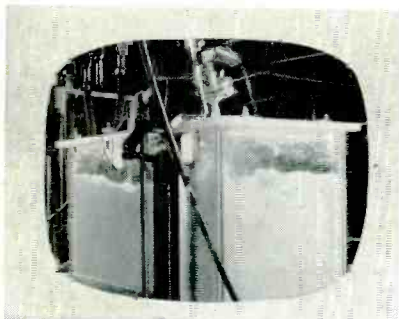

Final screen quality and focus check. Here on an automatic test unit, a trained inspector examines a test pattern on a finished picture tube to determine screen quality and picture focus. This is but one of 26 different tests each Silverama must pass at this test unit before it is okayed for sale and distribution. Tubes failing a single test are automatically rejected.

RCA ELECTRON TUBE DIVISION, HARRISON, N. J.



The Most Trusted Name in Television